

Casa Qualcosa

A Workshop with Besler & Sons
Erin Besler, Ian Besler

Syracuse University School
of Architecture in Florence
David Shanks, Luca Ponzi

Besler & Sons

<https://www.beslerandsons.com>

Erin Besler, Ian Besler

Syracuse University School
of Architecture in Florence

<https://soa.syr.edu/>

David Shanks, Luca Ponzi

Thanks to Aurélie Frolet
and Stephanie Jazmines

April, 2019

Katrina Abad, David Acevedo,
Madeline Brandel, Tatia
Buziashvili, Boya Chao, Bryan
Cordova, Gaole “Stella” Dai,
Lindsey Dierig, Erin Doherty,
Dhvani Ketan Doshi, Evan
Elliott, Daryl Gonzalez, Jack
Hymowitz, Hanzhang Lai, Shaan
Lakshmanan, Adam Liu, Stephen
Marinelli, Luke Miller, Timothy
Mulhall, Kayleen O’Brien, Raj
Periwal, Michele Pfleuger, Daniel
Prendergast, Yunji Seong,
Suren Sivaram, Giovanna Veiga,
Nicholas Wahler, Haoyuan
“James” Wang, Cabrio Wang,
Shauneil Williams, Iris Yee, Xinhui
Zhang

Contents

Workshop Brief	vii
Sono un Geometra	001
Typologies	015
Elevations	079
Site Plan	147
Material Swatches	205
Roof Profiles	239
Doors	267
Windows, Shutters.....	279
Stairs	301
Fence, Gate, & Balustrade	319
Mouldings	347

Workshop Brief

Erin Besler, Ian Besler

The situation has been much muddled by the tendency of the modern movement, since the time of William Morris, to gather up all decent buildings under the rubric of "architecture". This was a warm, friendly and egalitarian thing to do, but it must now seem as historically crude and as perniciously confusing as Nikolaus Pevsner's proposition that Lincoln Cathedral is architecture and a bicycle shed is not. The distinction was made on the basis that Lincoln Cathedral had aesthetic pretensions and bike sheds don't.

This was not only a piece of academic snobbery that can only offend a committed cyclist like myself, but also involves a supposition about sheds that is so sweeping as to be almost racist. How can he know that any particular bicycle shed, or even the whole typology of 'bicycle shed' in general, was conceived without aesthetic intentions? What one can know by practiced observation, however (and what Pevsner may even have meant), is that cathedrals (including ugly ones) are generally designed modo architectorum, and bicycle sheds (even handsome ones) are more commonly done in one of the numerous other modes of designing buildings available.¹

Perhaps no topic today presents as many questions for architectural practice and pedagogy as the distinction between expert and amateur designers and builders. Limitations in access to material resources, fabrication tools, and labor have historically served to reinforce this distinction. More recently, the cost and expertise required to effectively apply proprietary B.I.M. software systems to the design and build process, along with the impositions of education, certification, regulation, and licensure, have (particularly in the United States) sought to underline and enforce the boundary between

a class of expert practitioners from less skilled amateurs.

But with the advent of easy-to-use consumer-oriented design software, online video platforms for sharing and viewing instructional content, and social media for circulating and consuming imagery, the relevance, necessity, and procedures for maintaining these boundaries is an increasingly contested territory.

This defensive impulse has primarily manifested as an insistence that certain structures are architecture, while others are not. Published in 1964, Bernard Rudofsky's exhibition catalog

turned book Architecture Without Architects: A Short Introduction to Non-Pedigreed Architecture presents a photographic and descriptive survey of vernacular structures from around the world. Arguing for an expanded inclusion and consideration of building forms typically considered unlicensed and therefore unremarkable at best, Rudofsky nonetheless seems resigned to the idea that “vernacular,” “anonymous,” or “spontaneous,” architecture is no longer possible in a contemporary context: “There is much to learn from architecture *before it became an expert’s art*,” (emphasis added) he writes in the

preface, implying that the role of the amateur is exclusively in the past.²

But despite the pre-industrial constraints that Rudofsky applies to his inquiry, “anonymous” building and “spontaneous” design practices have continued apace, and are as robust and varied today as the contemporary canon of “Architecture With Architects.” Such buildings, however, have yet to enjoy their own dedicated exhibition at the Museum of Modern Art.

In order to acknowledge, examine, and document the typically under-

recognized forms of creative practice and knowledge circulating through these buildings, this workshop examines the recent phenomenon of “non-pedigreed” building practices in Italy, known colloquially as the “Casa del Geometra.”

The geometra is a regulated profession in Italy more broadly described as a surveyor, but whose activities and practices now range from arbitration to design to engineering. Recent relaxation of building code restrictions has allowed the licensed geometra to design residential housing up to a maximum of two floors,

despite possessing minimal or no design education. The “Casa del Geometra” can perhaps be understood not as an isolated phenomenon, but as one more addition in a recent and increasing series of very public challenges to the autonomy of the architect as the lone expert in the realm of building design and construction practices. Through a study of photographs of existing homes designed by geometras (or possessing the nuances and novel characteristics of the “Casa del Geometra”) found primarily in exurban developments, students will work in groups to research and document specific topics

related to these homes and the professionals that design them to produce a collective catalog or taxonomy of building details, doors, windows, fences, bricks, planters, moldings, roofs, as well as building practices, regulation, and daily life. The pattern book of sorts will act, similarly to Rudofsky's Architecture Without Architects, as documentation of this still-emerging phenomenon, as a speculative exhibition catalog for the (likely never to occur) show "Architecture With Geometras," including speculations on possible under-explored and unexploited opportunities for construction.

1. Reyner Banham, “A Black Box: The Secret Profession of Architecture,” A Critic Writes: Essays By Reyner Banham (Berkeley: University of California Press, 1996) 293.
2. Bernard Rudofsky, Architecture Without Architects: A Short Introduction to Non-Pedigreed Architecture (Albuquerque: University of New Mexico Press, 1964), n.p.

Sono un Geometra

Cabrio Wang, James Wang

GEOMETRI



1929 - 2019

History

Highschool Diploma

6 months Vocational Training Course

State Examination



Registered Geometra

Highschool Diploma

2 Years in Technical Institute

6 months Intern

State Examination

Registered Geometra



- A. Topographical surveying / Measuring
- B. Operations of tracing of firm and consortium
- C. Measurement and division of rustic funds
- D. Measurement and division of urban / civil construction
- E. Estimation of rural areas and funds
- F. Estimation of urban areas
- * G. Estimation of dead stocks
- H. Purely accounting and administrative
- * I. Taking care of farms
- J. Project, management, surveillance and liquidation of rural area
- K. Design, management and supervision of modest civil construction



Registered Geometre
100,000



20,000 €

30,000 €

Annual Income



Disatisfaction
32%

3,000 €

7,000€

Design Fee



Volumetric Calculation

Value Estimation

100 €

300 €

Design Fee: 8% - 16%

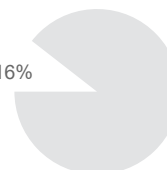

ARCHITECTS

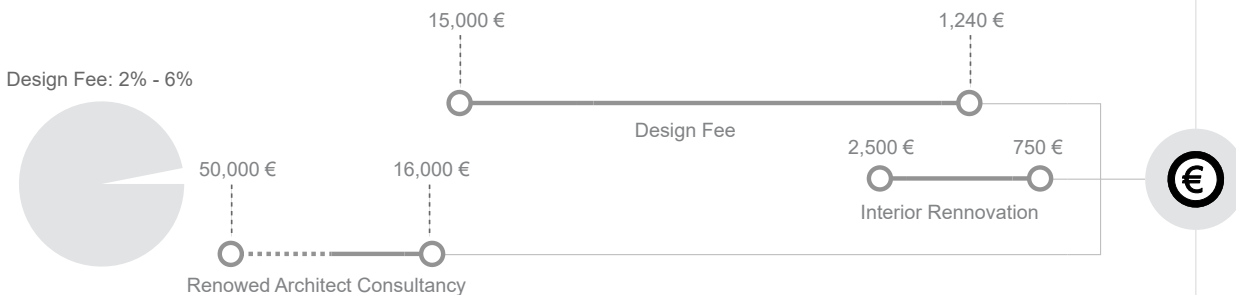
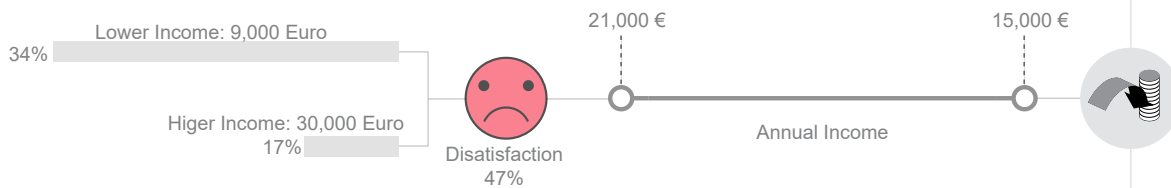
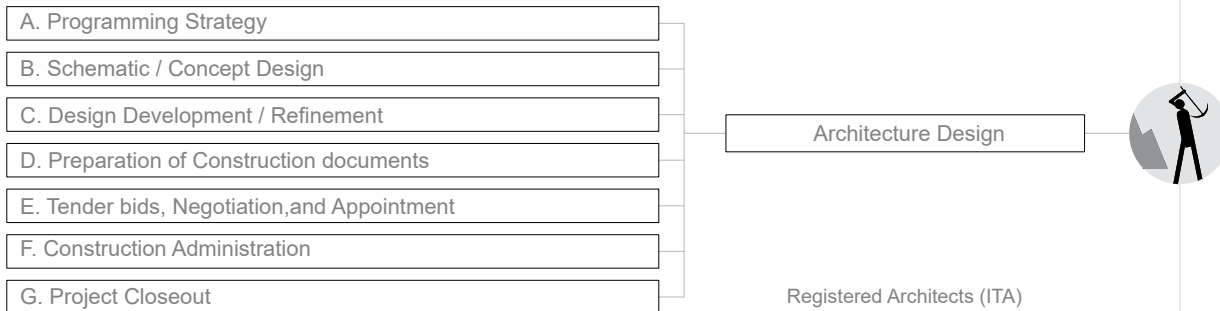
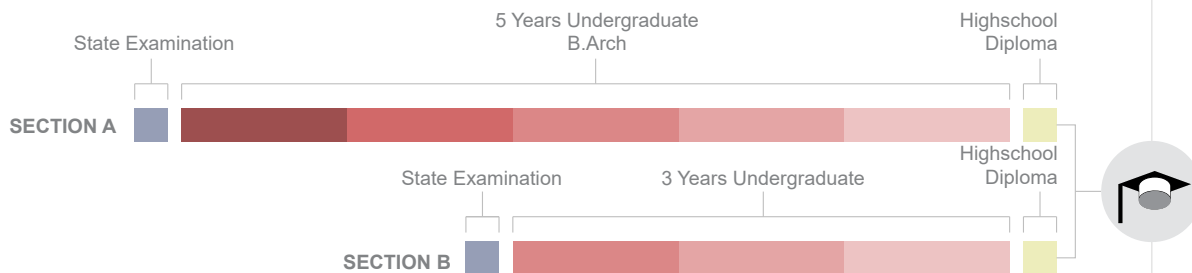

Sono un Geometra

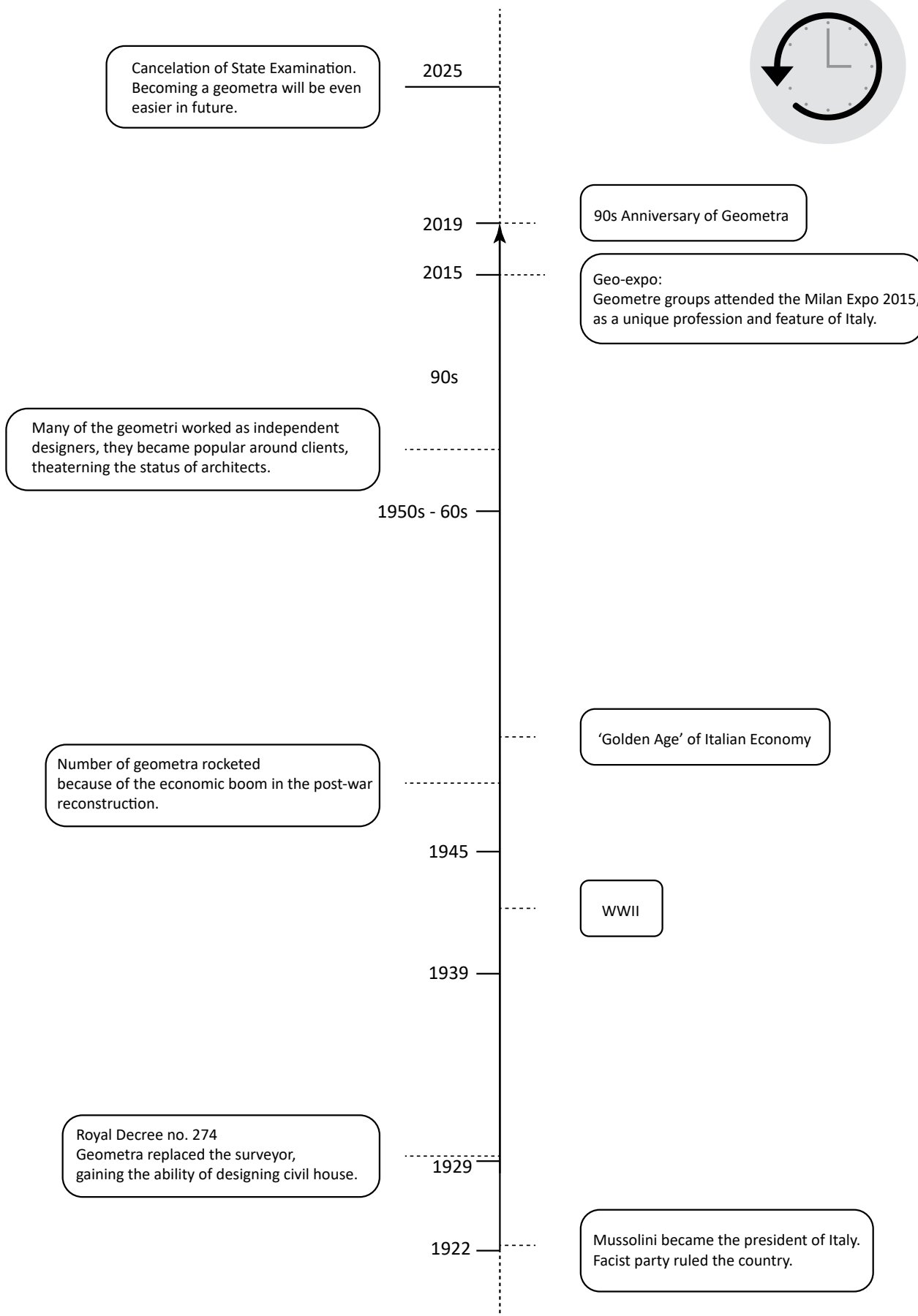
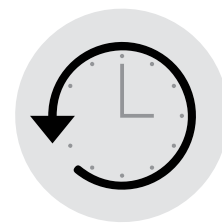

Timeline

Sono un Geometra

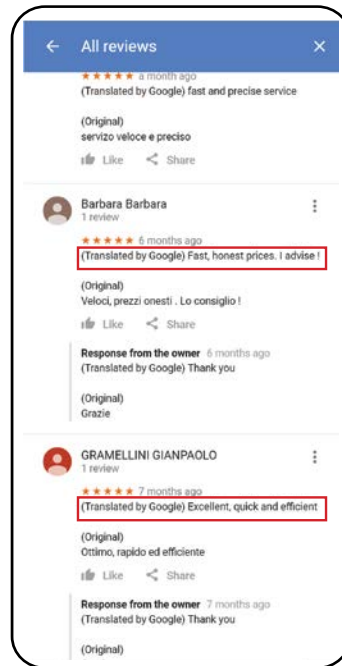
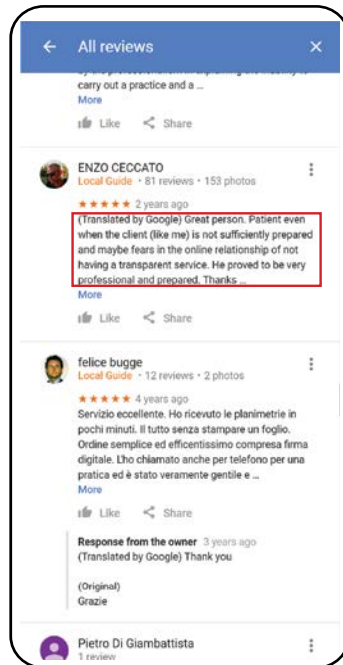
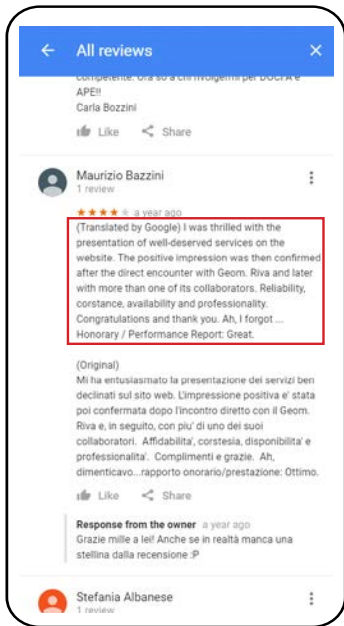
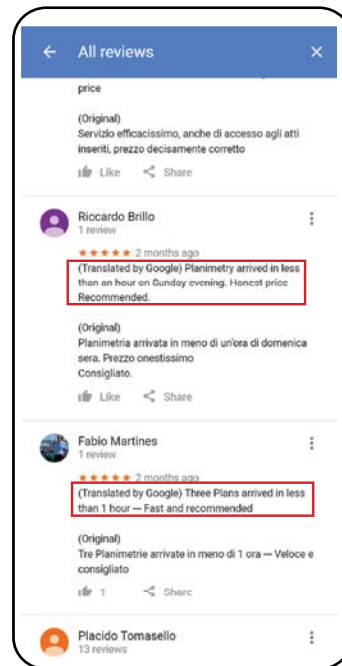
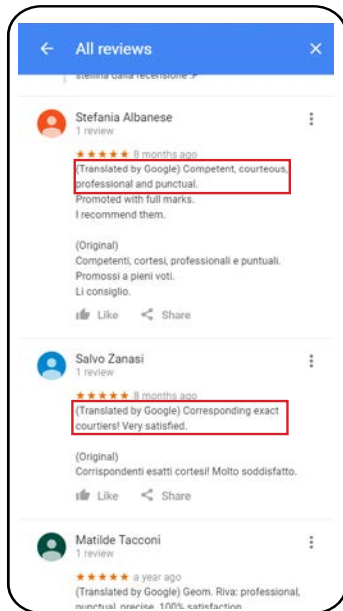
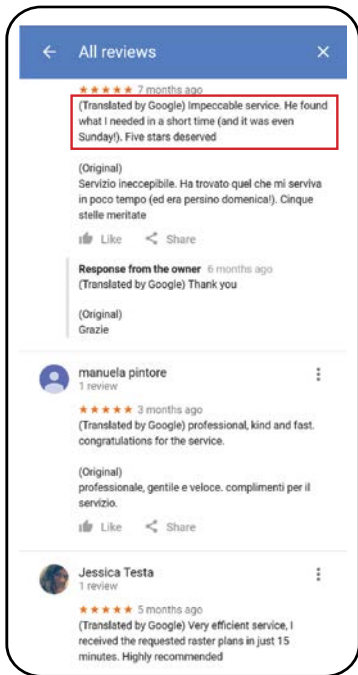

Reviews

Sono un Geometra

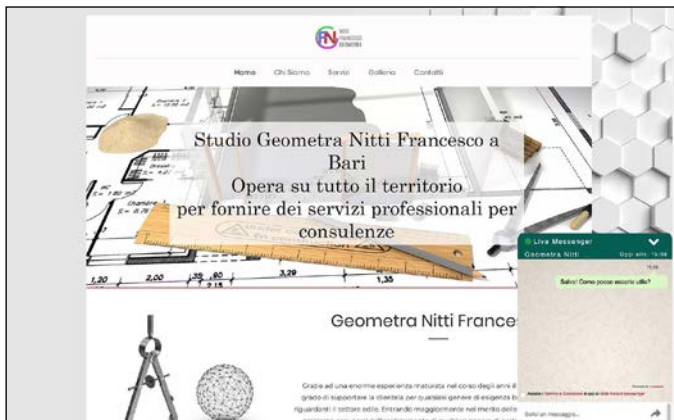
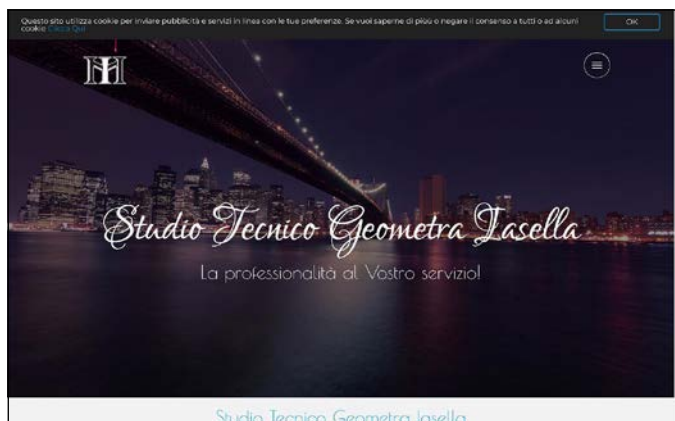
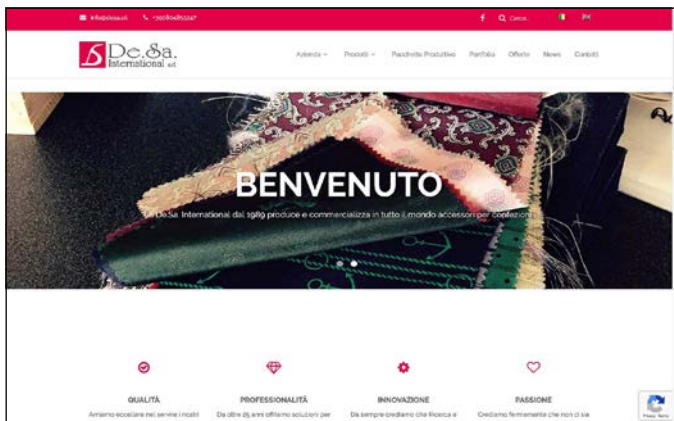

Websites

Sono un Geometra

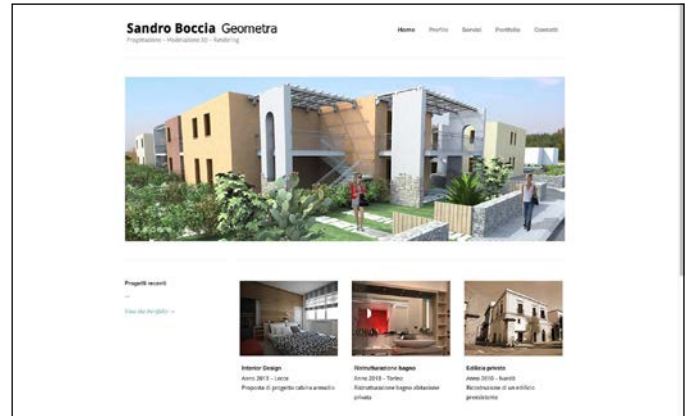

Sono un Geometra

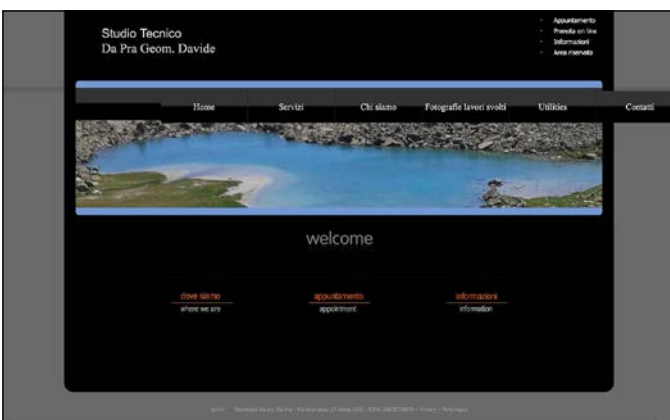

Websites

CORRIERE AREZZO

HOME CHRONICLE ACTUALITY POLICY ECONOMY AVERAGE SHOWS SPORT IMOTORI COURIER & BUSINESS EARTH AND TASTE

WEST IMMIGRATION

s Active

o incentivi





AREZZO

Work stress, surveyor gets Inail income

22.04.2019 - 00:37

It "burst" at work . He has contracted an **occupational disease** caused by excessive stress due to exposure to the angry complaints of citizens living in public housing. And for this reason a 52-year-old surveyor from Arezzo won the case with **Inail** . who was ordered to pay the

SCOPRILA IN TUTTE LE CONCESSIONARIE MINI ADERENTI.



CAMPEGGIO PRINCIPINA

Il Camping preferito dalle famiglie e dai bambini, immerso nella rigogliosa pineta della Maremma Toscana, a pochi passi dal cristallino mare di Principina. Relax e svago per una vacanza felice e indimenticabile.

Nuova F

Anticipo zero

€ 289

TAN 4,95% TA

E fino a € 6.50

Scopri di più



CORRIERE AREZZO TV



Sri Lanka, images from inside the church after the attack



Christmas in Rome, the lighting of the fire of the goddess Vesta



The Easter of the Fire Brigade, to the rescue of a dog trapped in a gutter

Network Publish your products Shopping cart Login Facebook Login

edilportale Cerca tra aziende, prodotti, news, bim&cad ...

TOUR 2019

In 10 years, will the Italians still buy a house?

Edilportale Tour 2019 in Pescara explains the evolution of the building that adapts to the new demand

03/28/2019 See Update of 04/19/2019 0 Comments 3111

30

f Recommend

Twitter Tweet

0

Comments



28/03/2019 - "Will there still be homeowners in 10 years? Will there be demand for jobs?" Thus **Marco Marcatili** , an economist at Nomisma, opened the works of the Pescara stage of **Edilportale Tour 2019** .



FibroTEK Fibrotubi

PANNELLO SOTTOTEGOLA TERMOISOLANTE



Promat

promatect 100X

La lastra antincendio universale

SCARICA LA BROCHURE



VELUX

Free advice from a VELUX designer

Book

edilportale.com/Banner/Click?idbanner=517699&url=https%3A%2F%2Fwww.edilportale.com%2Fesmartnews%2F501669

Network Publish your products Shopping cart Login Facebook Login

edilportale Cerca tra aziende, prodotti, news, bim&cad ...

PROFESSION

Surveyors: 'our incomes are up 6.3%'

by Alessandra Marra

For Savoncelli the performance is positive considering that the neighboring professions (engineers and architects) remain in heavy trouble

01/25/2019 See Update of 04/08/2019 1 Comments 3183

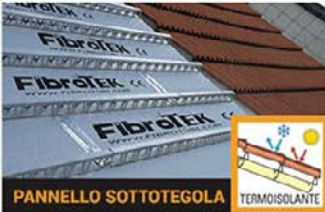

Photo: goodluz © 123RF.com

25/01/2019 - Surveyors' incomes have no crisis: in 2018 their average annual income registered a 6.3% growth.

FibroTEK Fibrotubi



PANNELLO SOTTOTEGOLA TERMOISOLANTE

Promat

promatect[®] **100X**

La lastra antincendio universale

SCARICA LA BROCHURE

VELUX



Free advice from a VELUX designer

Book

PROFESSIONALS COMPANIES SAFETY ENERGY EFFICIENCY PROCUREMENT FOCUS CONFERENCES COMPANIES SHOP

NEWSLETTER

Professionals

Surveyor killed: can you die for a real estate appraisal?

The number of foreclosed properties is growing. The consequence is sometimes a crazy gesture of the interested parties. But to pay the costs can also be professionals who have nothing to do, while doing their job.

Of Technical Editorial - November 14, 2018 © REPRODUCTION RESERVED

Share on Facebook Tweet on Twitter G+ P in



Surveyor **Marco Carlo Cassano**, 44 years old, was killed in Portacomaro d'Asti by the 91-year-old owner of the building in which the technician, charged by the Court, was about to carry out a real estate appraisal, as part of a proceeding real estate enforcement.

The surveyor did not have time to enter the small fenced yard in front of the house, where the first shot started. The man fell to the ground and was rescued by a couple. While the ambulance was arriving, a second gunshot was fired, which put everyone to flight.

The carabinieri, who arrived shortly afterwards, immediately understood what had happened: the owner of the house where the surveyor was supposed to have carried out the survey had fired. While the ambulance is transporting Cassano to the Asti hospital, the carabinieri broke into the farmhouse from which the shot was fired. There, sitting in an armchair, they found Dario Cellino, with the gun in his hand. He was arrested on charges of attempted murder and taken to the barracks. A few minutes later, the news of Massano's death arrived.

SCEGLI CASA NUOVA

LO SHOWROOM DIGITALE DI CASA.IT PER LE NUOVE COSTRUZIONI

SCOPRI

Economy

A "Palazzo delle Professioni": engineers, surveyors and architects are looking for a house in Forlì

"The Palazzo delle Professione is a container of several hundred square meters and in its organization it will have to present itself as a usable, open space of confrontation and sharing between professions towards institutions and towards citizens".

FT Editorial board
MARCH 29, 2019 13:16



The exploratory call for expressions of interest for the search for properties located in Forlì has been published which, in terms of representativeness, location and type characteristics, can house the "Palazzo delle Professioni", to build the unitary headquarters of the Orders and

The most read today

1 Good-bye coins, the revolution in the supermarkets has started: at Conad, spending is rounded up

2 Easter bridge, many choose the farmhouses for lunch. Also offered health menus



Expired Car Insurance? What are you waiting for? Do

PROMO.VERTI.IT



Amazon shares: job offer to do at home

WWW.NEWSDIQUALITA.IT

Sponsored by @utbrain |>

LATINA, THE URBAN CENTER IS BORN

Citizens and professionals can participate in the planning of the city PHOTO

April 18, 2019, at 08:39

Share



Already more than 50 people have joined the Urban Center Latina, home of the city and the territory. As decided by the meeting that took place yesterday in the De Pasquale hall, the Municipality will provide a place where professionals (surveyors, architects, technicians), associations and citizens can meet on a regular basis. In the first phase, D'Annunzio's multimedia room was identified as the place to hold the meetings. As soon as the works at the former Ruspi garage are completed, the meetings can move there.

The objective of the association that is being established is to give life to a participatory planning of the city, with the involvement of those who use the places.

SEMENTI SCARPARO 

Specialisti in orticoltura e giardinaggio

LATINA - VIA CONGIUNTE DX, snc
TEL 0773.663.878 - www.sementiscarparo.it

Health



TOP, REFLUX, ... WITHOUT RUGS!

Sirio makes custom-prostheses and braces with advanced techn

ni, Nutritionist

At Aniccia, the excellence of c

LATEST NEWS

12:16 Castelli Romani, all full for Easter and Easter Monday despite bad weather

11:36 Abusive port of white weapon: an 82-year-old from Latina reported

11:21 Appia Day, the ancient Appia from Frattocchie in Rome in just 12 km on foot

10:09 From the nomad camp in Castel Romano, he was asking Rome to steal offers

Costume and Society
Mobile Facebook Twitter RSS Director Archive Pharmacies on duty Weather

WhatsApp Newsbiella

Il Biellese Magico e Misterioso
a cura di Roberto Gremmi

WHAT IS THE WEATHER LIKE

NOW
16.4 °C

MAR 23
9.8 °C
12.7 °C

MER 24
9.1 °C
11.8 °C

CONSULTA IL METEO

SECTIONS

- Pet shop
- At the table with taste
- Wellness and Health
- Connecting rod engines
- Biella that you DO NOT like
- Biellese Magico and Misterioso
- Home Construction
- CNA Biella
- Check the weather
- CSEN News

COSTUME AND SOCIETY | 13 february 2019, 19:00

1929–2019: the surveyor's profession is 90 years old

23 Consigliata



Former Vaglio Rubens Biella Institute

Exactly ninety years ago, on 11 February 1929, the surveyor's profession was born, established by Royal Decree n. 274. An important anniversary that the National Council of Surveyors and Graduate Surveyors intends to celebrate with a series of initiatives that will be held throughout 2019, with the involvement of the territorial Colleges and members. The National President of CNGeGL Maurizio Savoncelli in a mailing dedicated to all the members retraces the salient moments of the profession, from 1929 to the post-war period, from the 80s to today. The story of a profession that has been able to transform yesterday's versatility into today's

LINEA INCHIARO DI HDI ASSICURAZIONI

Ogni momento è imprevedibile

Sottoscrivi più di una polizza InChiaro e grazie allo sconto progressivo risparmi fino al 20%.

sella.it

AL CENTRO DEI TUOI PROGETTI



Gaglianico (BI)
Via Cavour 28 - S.S. Trossi - Tel. 015.543190

FESTIVAL DELL'ORIENTE



NUOVA

TETTO NERO A CONTRASTO



RICHIEDI PREVENTIVO

IN SHORT
Monday 22 April

Scopri l'offerta presso lo sportello Enerbit in piazza V. Veneto 3 a Biella.

ENER.BIT

CHRONICLES
0

"Houses for rent, tourists mainly look for three-room apartments". Prices from San Benedetto to Cupra

OF EDITORIAL - MARCH 29, 2019 @ 10:40AM

Facebook Twitter

According to the College of Surveyors of Ascoli, "the cost of renting in the riviera ranges from 570 to 1260 euros per month" referring to the annual mentoring fee



LA TUA POLIZZA

ANCHE A RATE MENSILI

AUTO

NOLEGGIO AUTO A LUNGO TERMINE

CASA - VITA - MALATTIA - INFORTUNI

AZIENDA - PROFESSIONE - MUTUI

LAST COMMENTS

- 2 Cupra elections. Luca Vagnoni presents his VIDEO team
zeta, zetta
- 1 New school of Acquaviva, all the doubts of the opposition
paco
- 2 "The center like a latrine", residents angry at San Benedetto
mirtilla7230, lux
- 5 Russotto shines but then Gentlemen and Ilari "burst". Magi puts his in and misses the substitutions
replicant, catwal, carlop, Nazzareno Perotti, carlop
- 1 Magi: "I'm pissed, so no." Rapisarda: "In the second half we didn't take the field"
catwal
- 1 Rimini-Samb 3-1. A beautiful Samb only in the first half. Then the rossoblu melt
rossoblu heart

Typologies

Madeline Brandel, Daryl Gonzalez,
Luke Miller, Xinhui Zhang

Typology



Type by Color

Typology



Type by Color

Typology



Type by Color

Typology

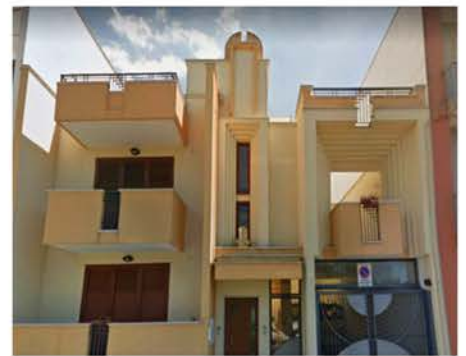

Type by Color

Typology



Type by Color

Typology



Type by Color

Typology



Type by Color

Typology



Type by Color

Typology



Type by Color

Typology

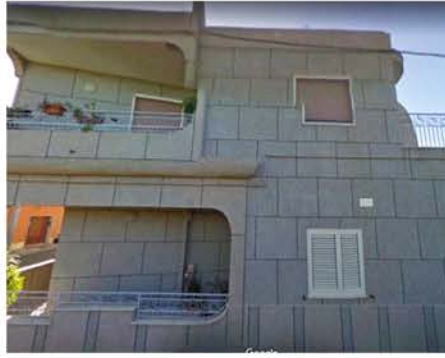

Type by Color

Typology

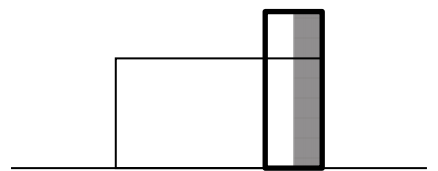
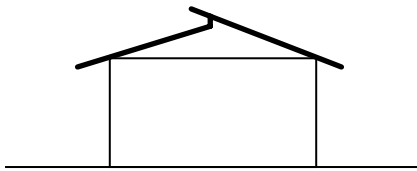
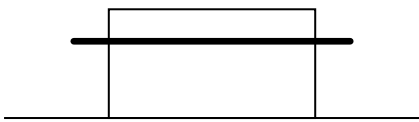
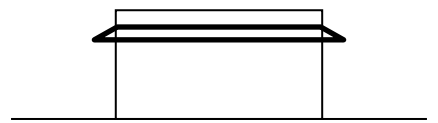
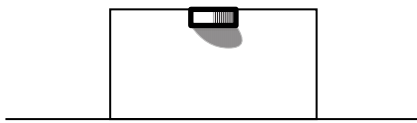

Typology

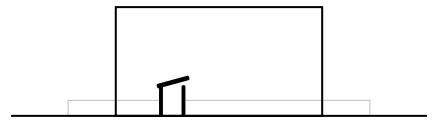
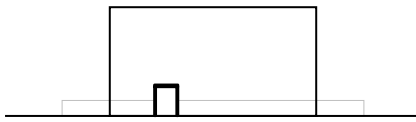
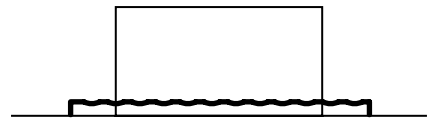
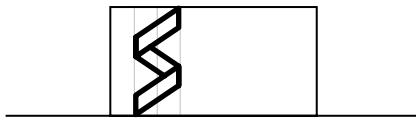
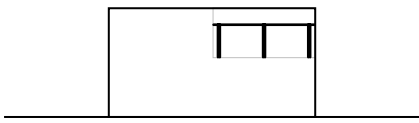
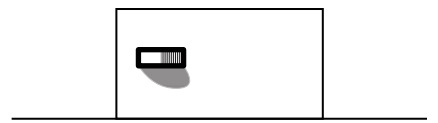
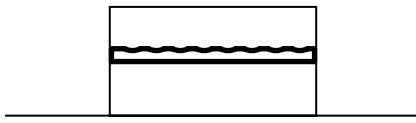
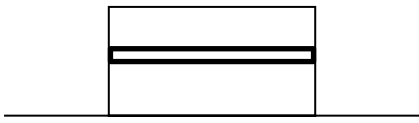

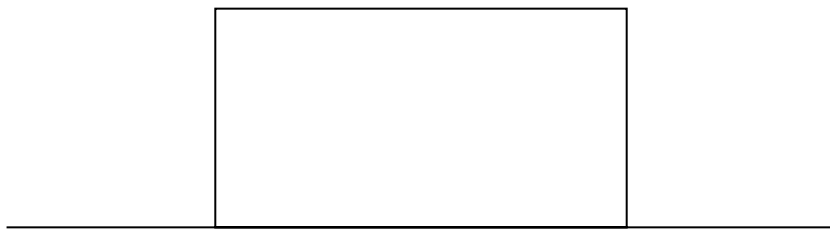

Plain Rooftop

Typology

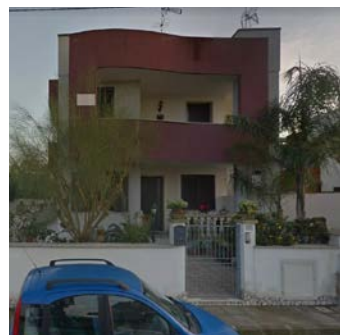
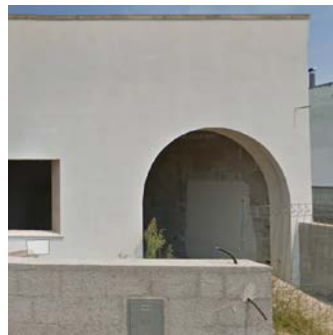
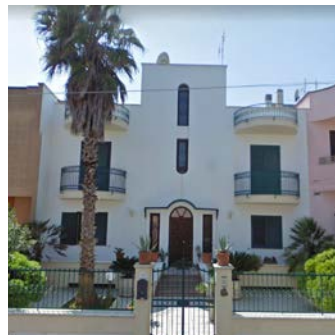
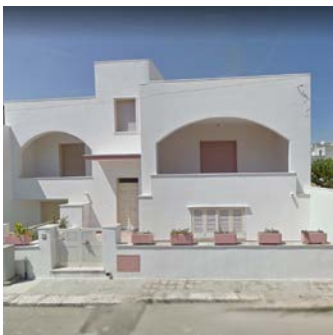
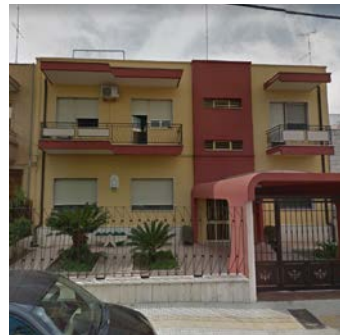

Plain Rooftop

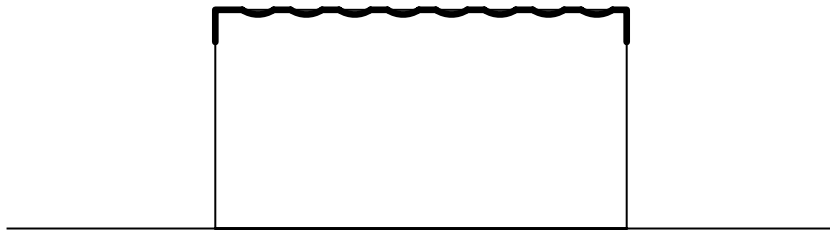

Undulating Parapet

Typology



Undulating Parapet

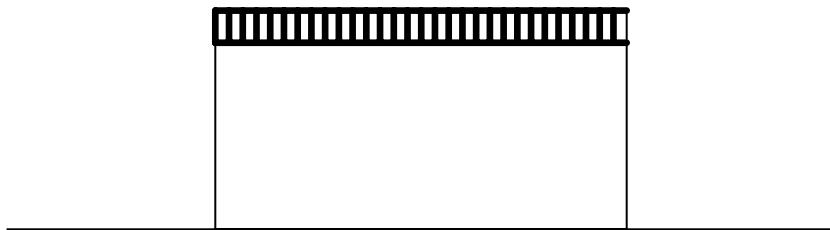

Balustrade Parapet

Typology



Balustrade Parapet

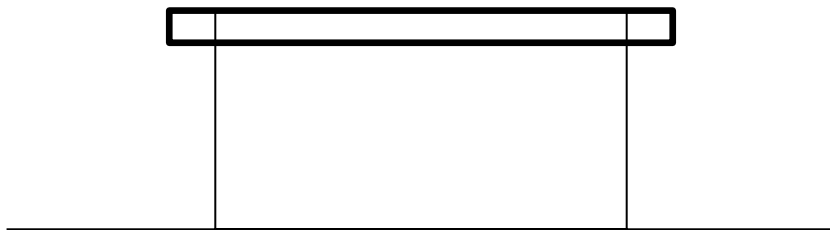

Typology



Rooftop Stripe

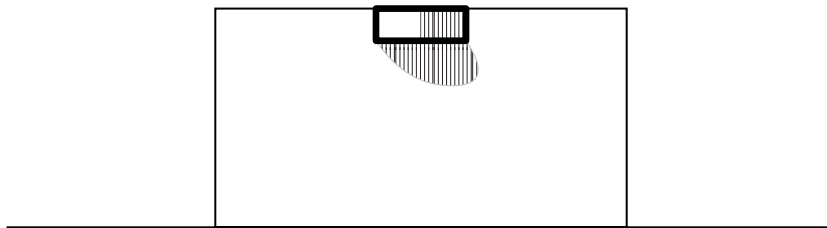

Rooftop Balcony

Typology



Rooftop Balcony

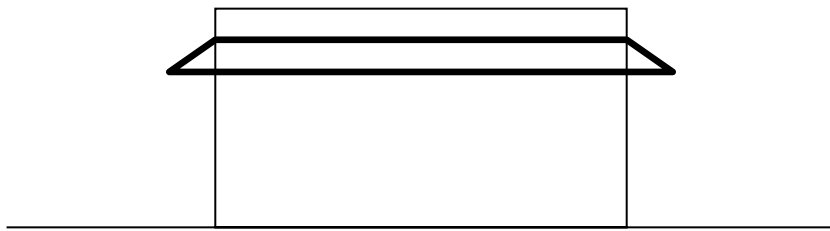

Chamfer Skirt Roof

Typology



Chamfer Skirt Roof

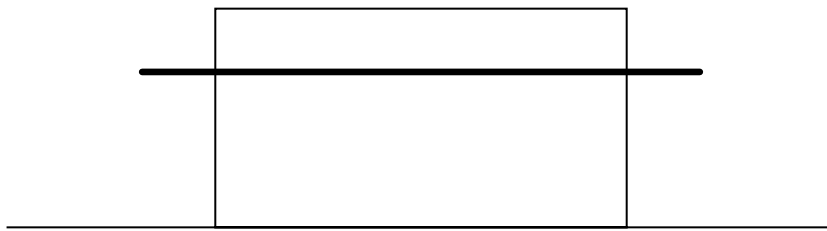

Planar Skirt Roof

Typology



Flat Skirt Roof

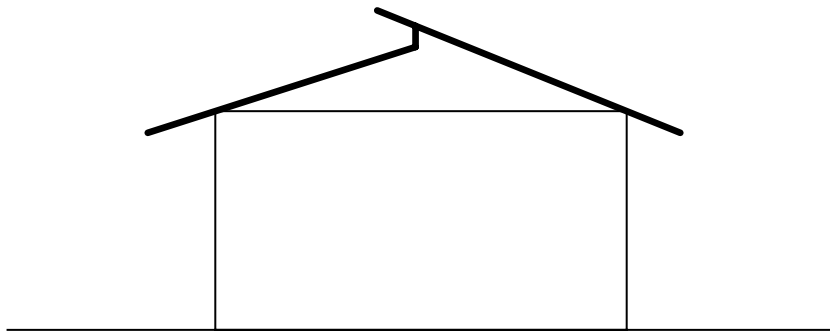

Gable Roof

Typology

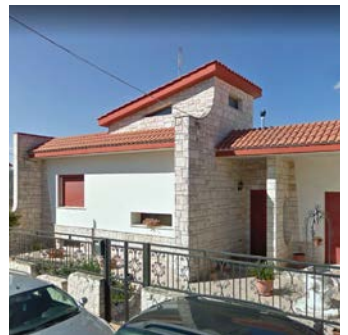
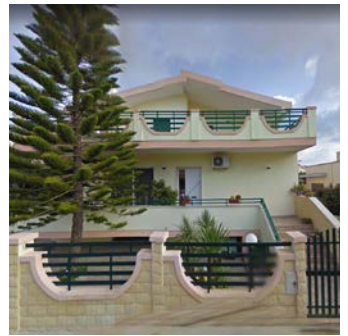
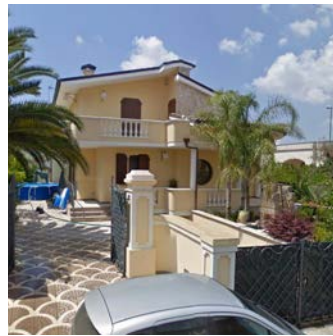
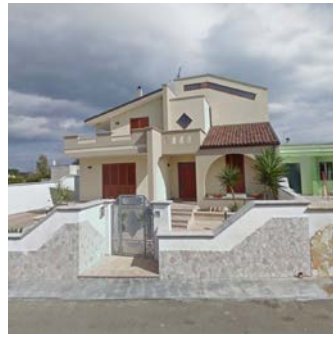

Gable Roof

Typology

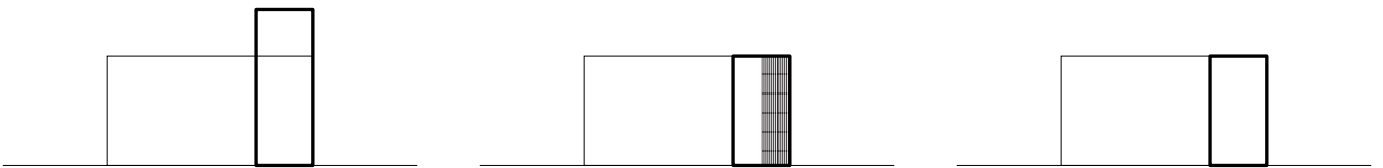
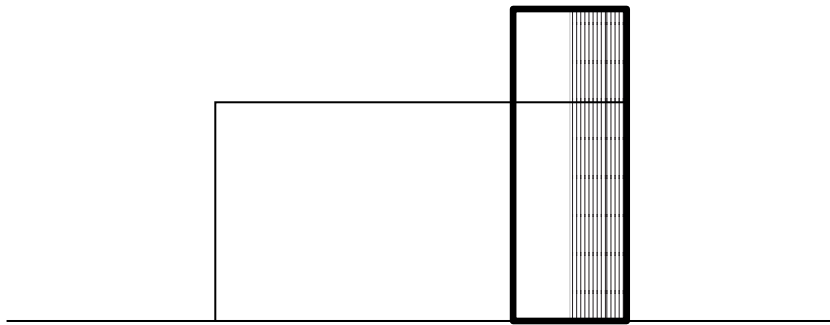

Double Massing

Typology



Double Massing

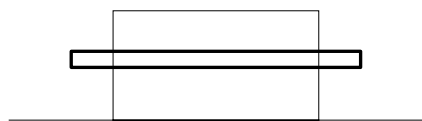
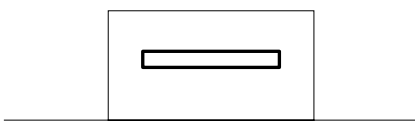
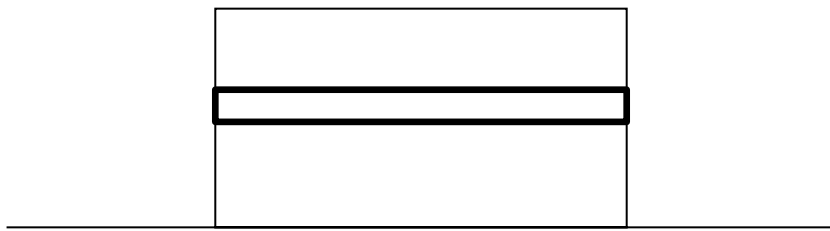

Stripe Balcony

Typology

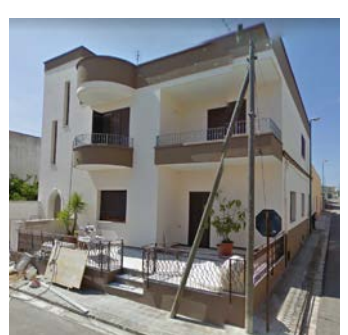
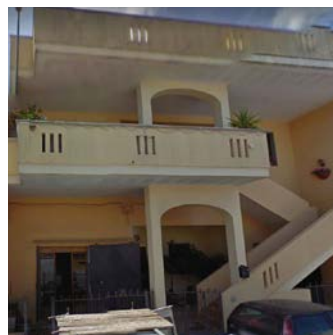
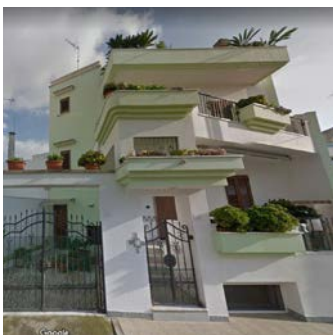
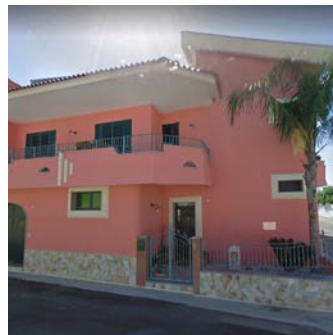
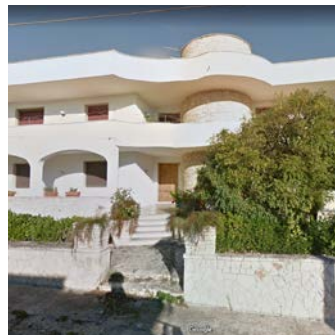
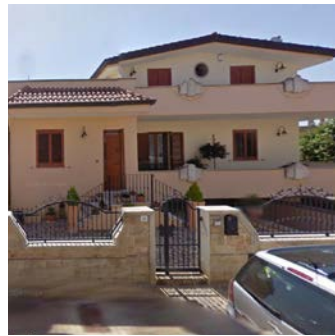
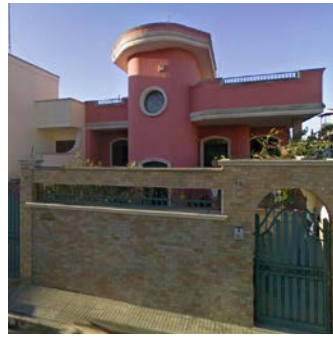

Stripe Balcony

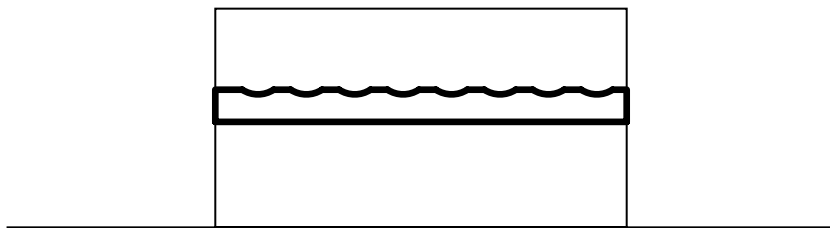

Undulating Balcony

Typology



Undulating Balcony

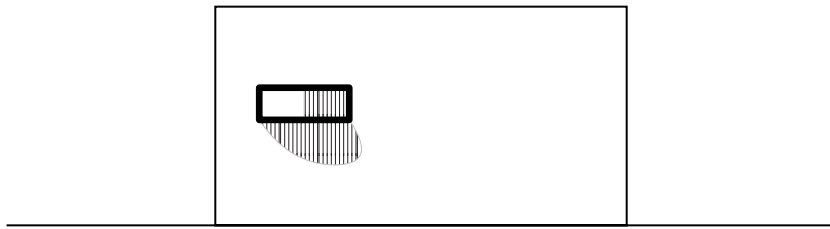

Semi Circular Balcony

Typology

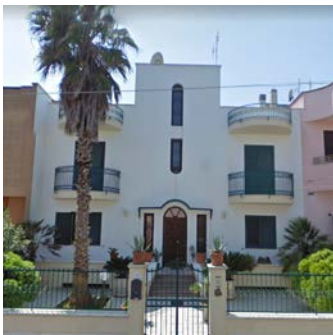
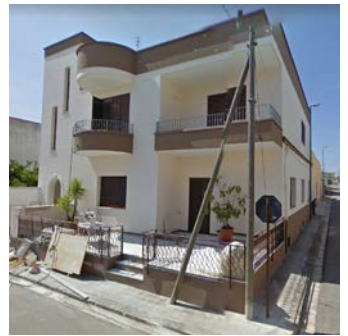
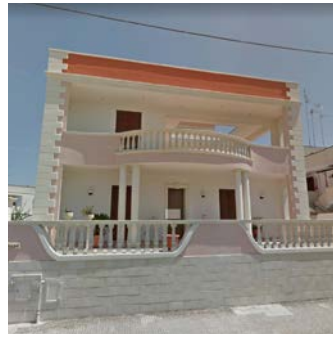
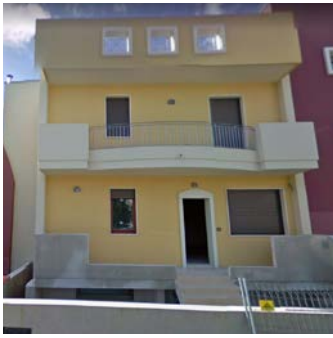

Semi Circular Balcony

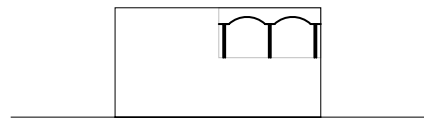
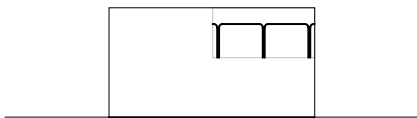
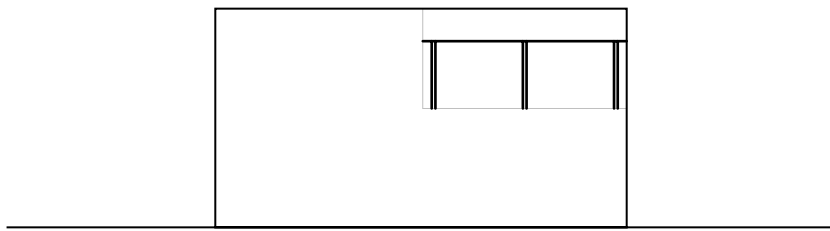

Typology



Loggia

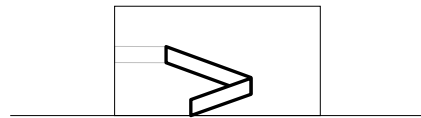
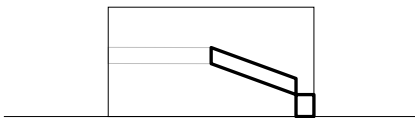
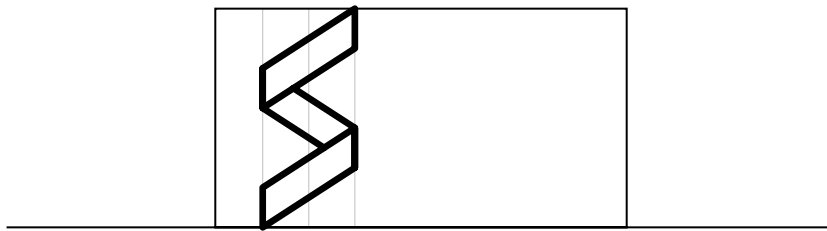

Exterior Staircase

Typology



Exterior Staircase

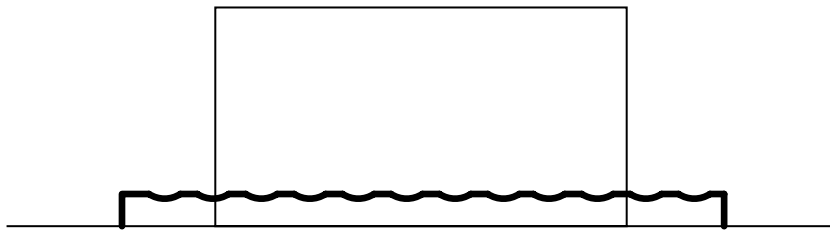

Undulating Fencing

Typology



Undulating Fencing

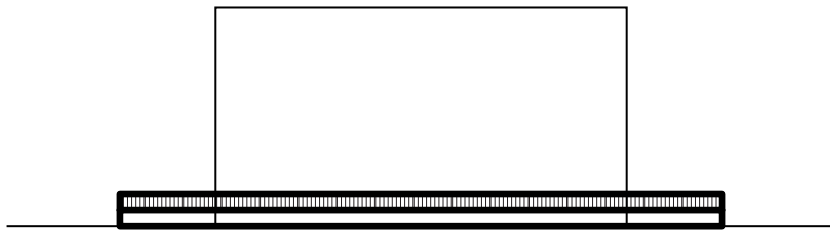

Half Balustrade Fencing

Typology



Half Balustrade Fencing

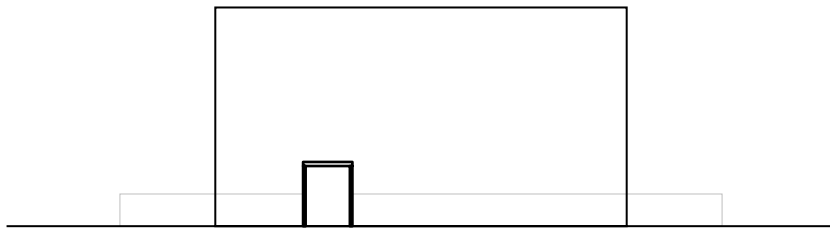

Post and Lintel Gate

Typology



Post and Lintel Gate

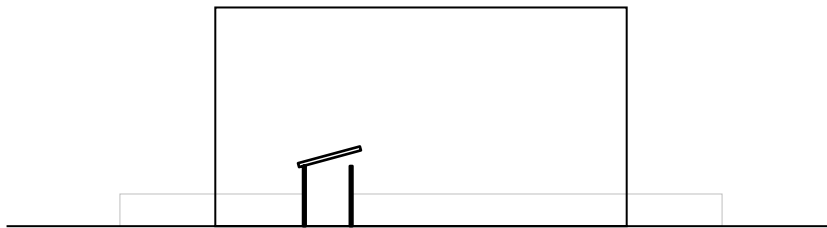

Inclined Gate

Typology



Inclined Gate

Typology

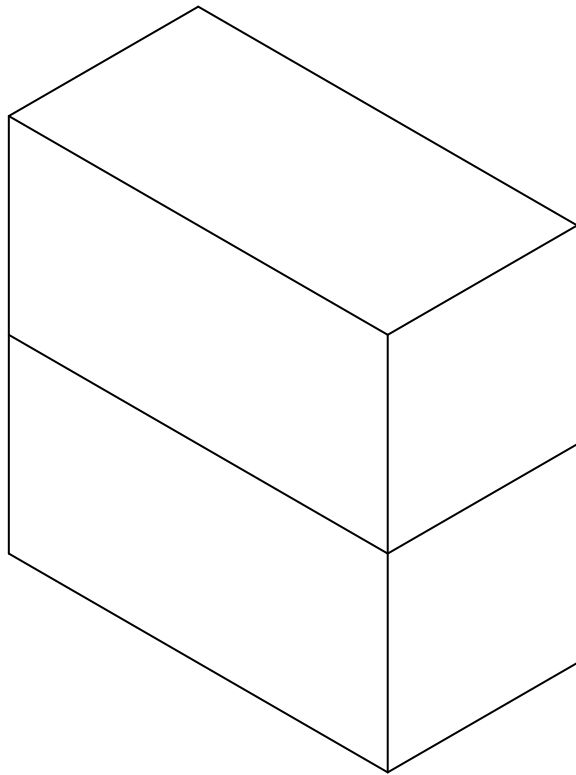
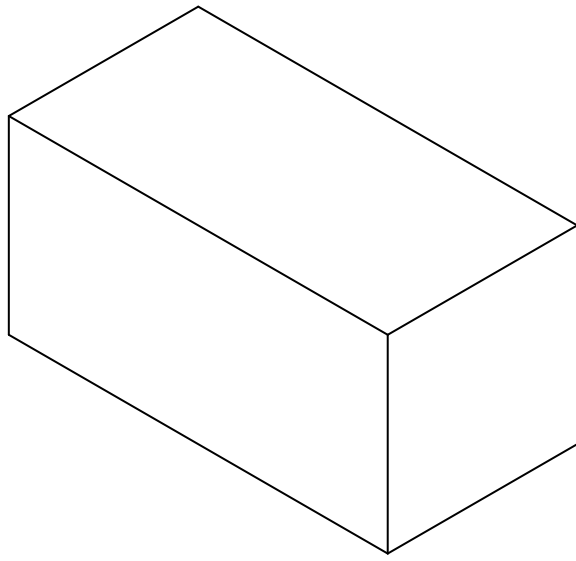

Typology

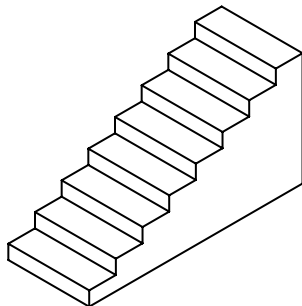
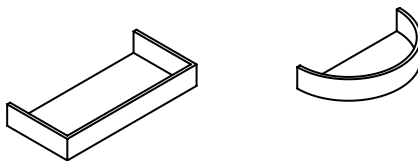
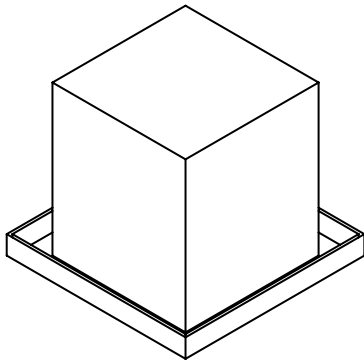
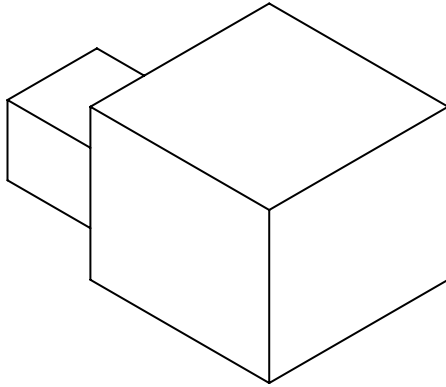
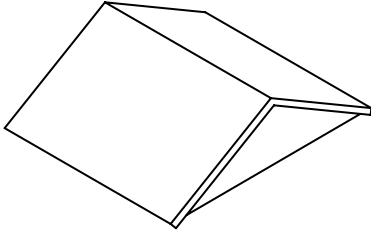

Typology

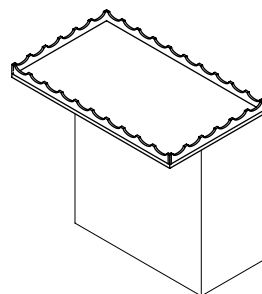
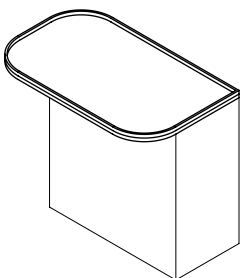
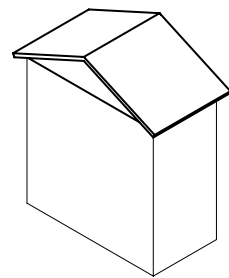
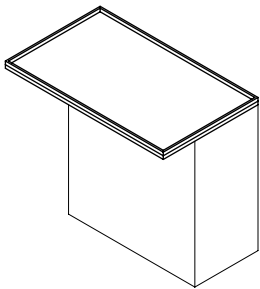
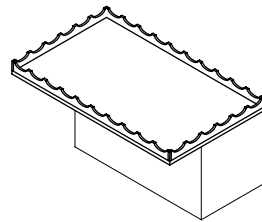
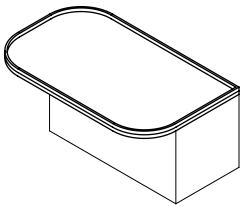
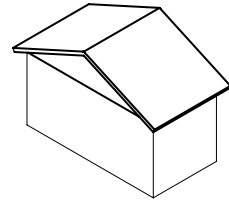
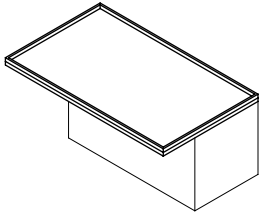

Typology

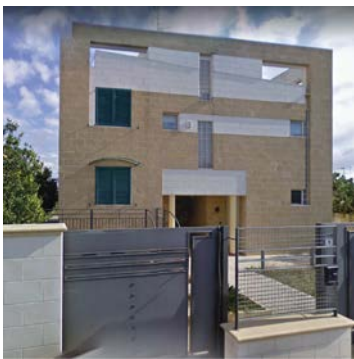

Typology

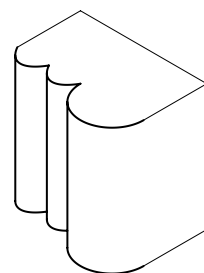
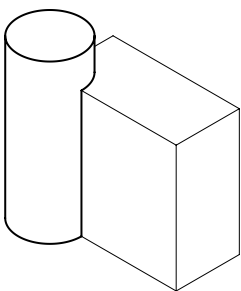
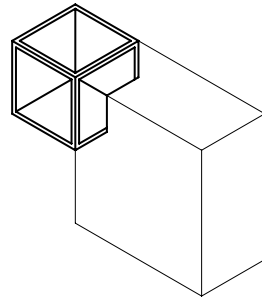
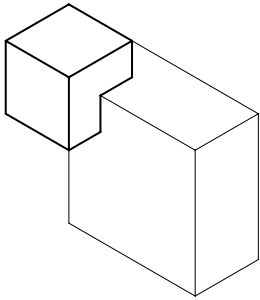
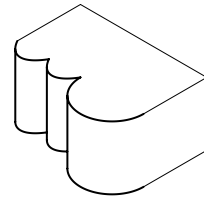
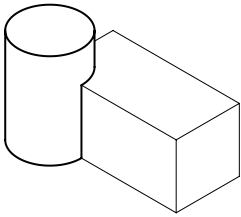
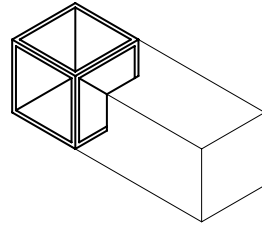
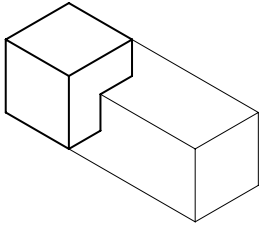

Typology

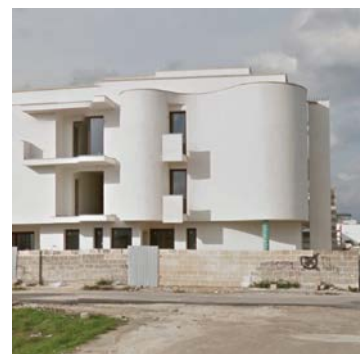
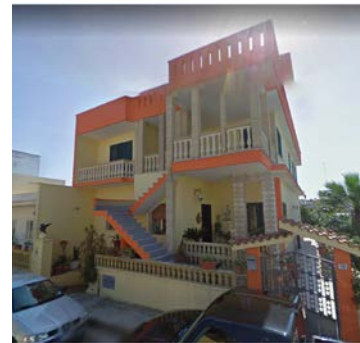
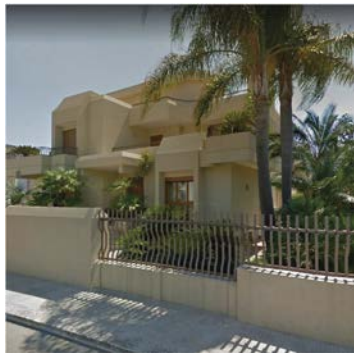
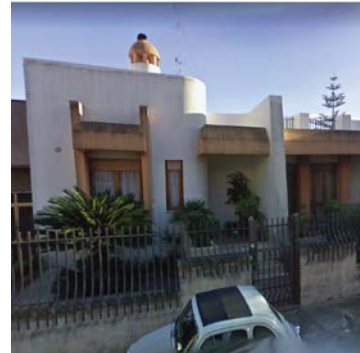
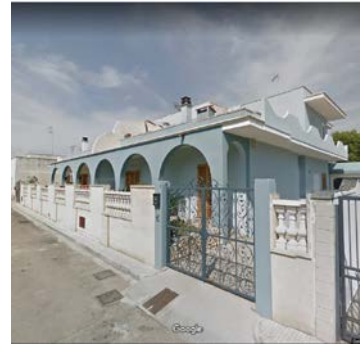

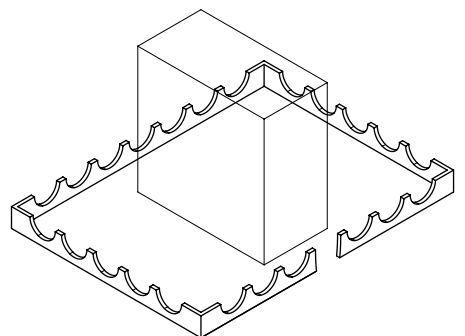
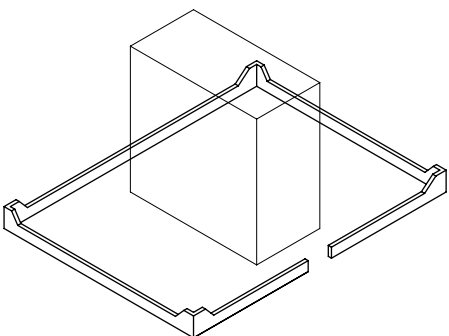
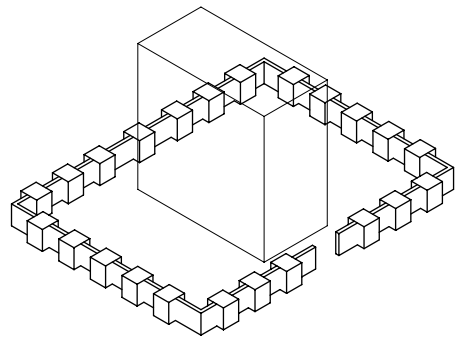
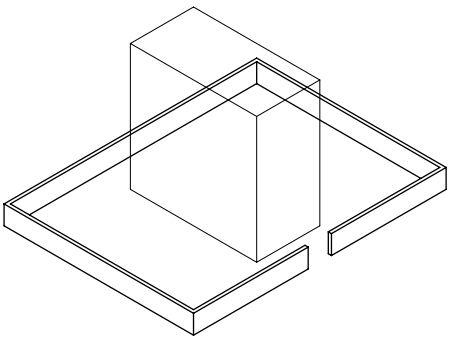
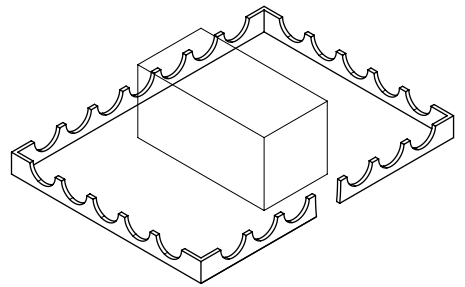
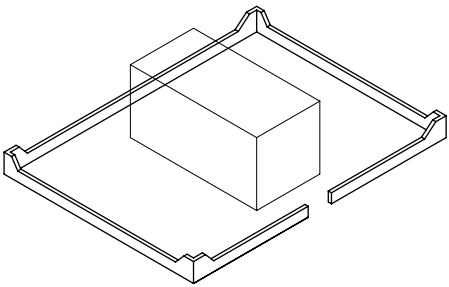
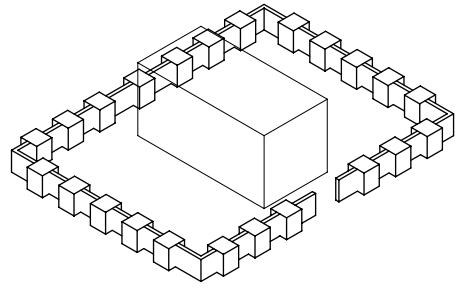
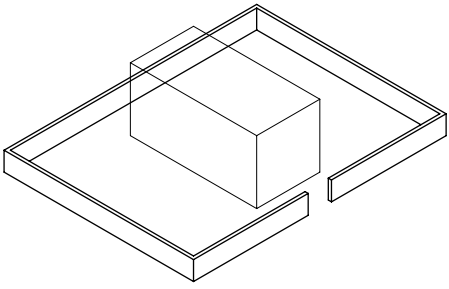

Typology

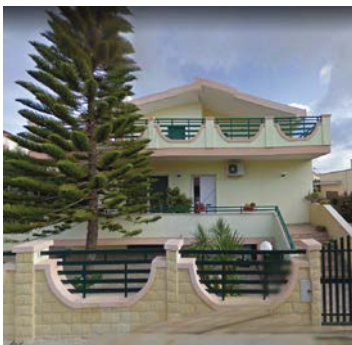
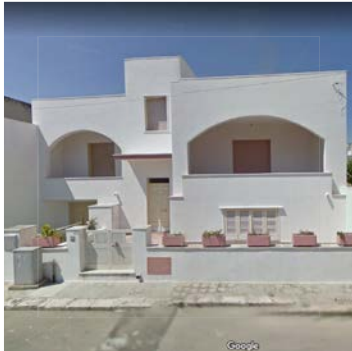
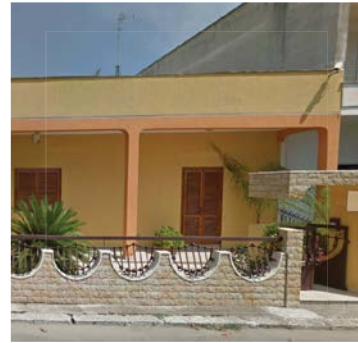
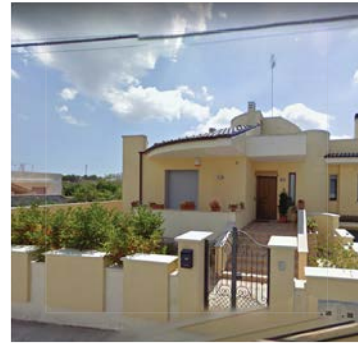

Typology

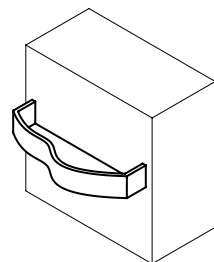
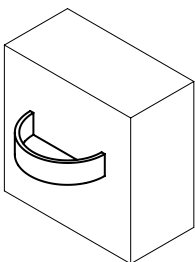
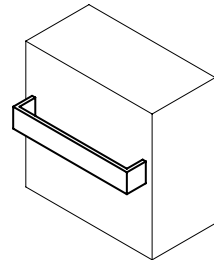
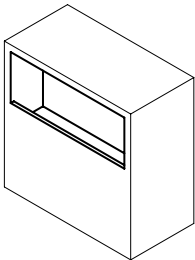
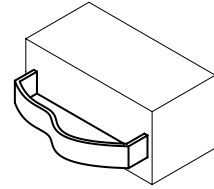
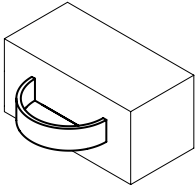
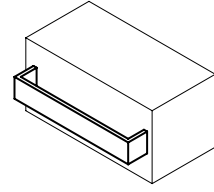
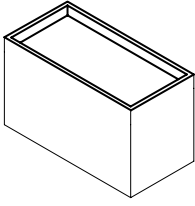

Typology

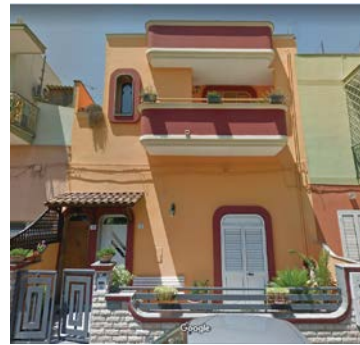
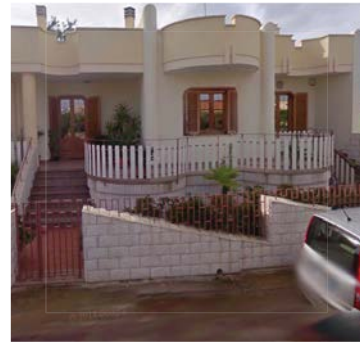

Typology

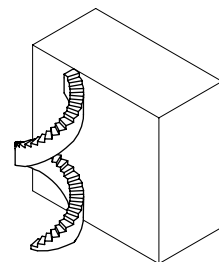
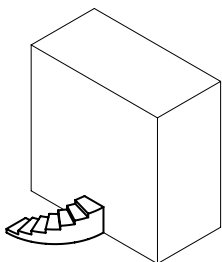
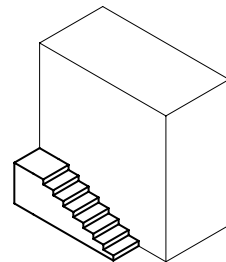
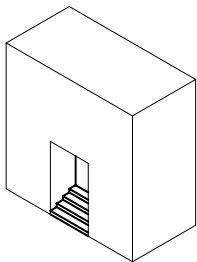
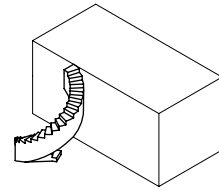
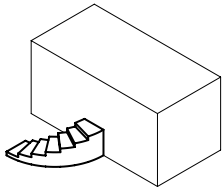
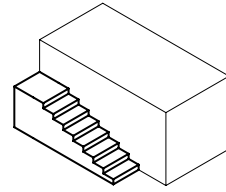
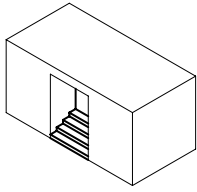

Typology

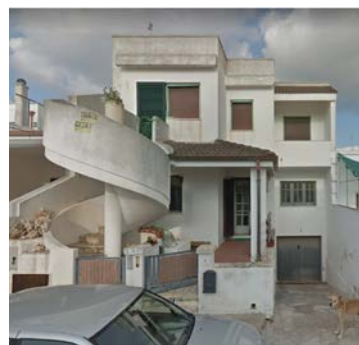
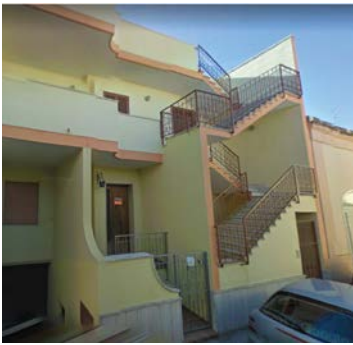

Typology

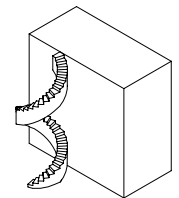
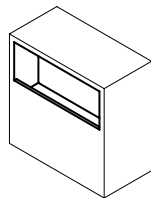
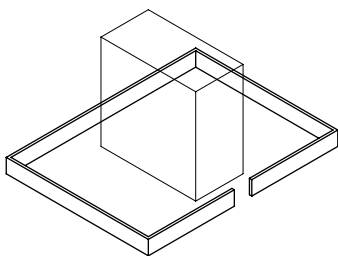
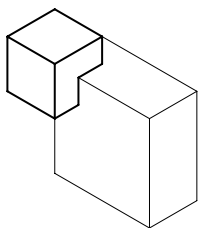
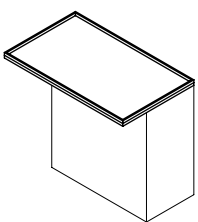
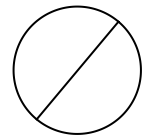
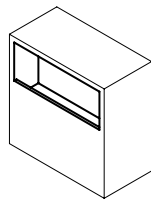
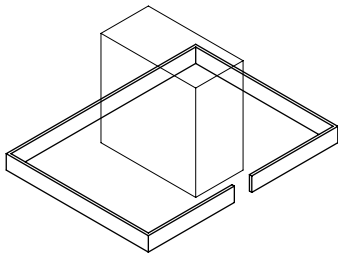
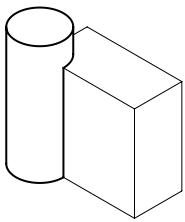
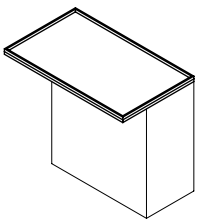
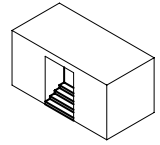
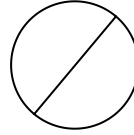
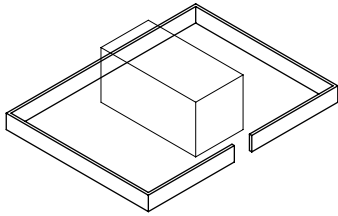
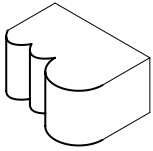
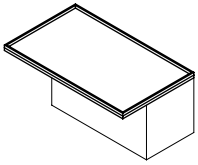
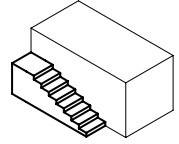
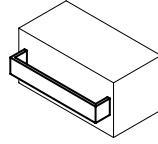
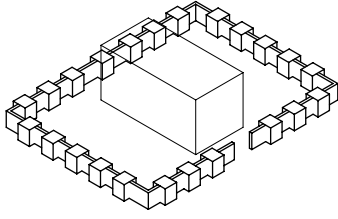
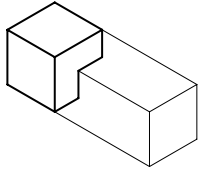
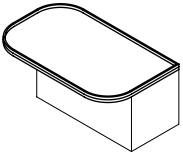

Typology

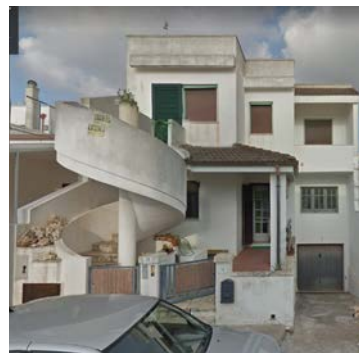
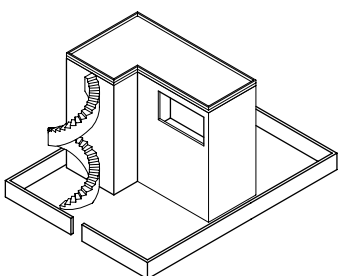
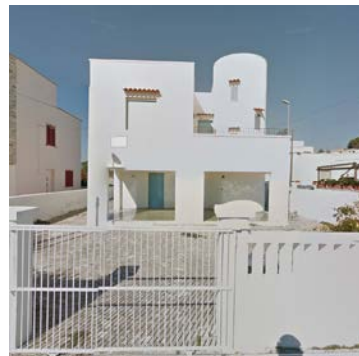
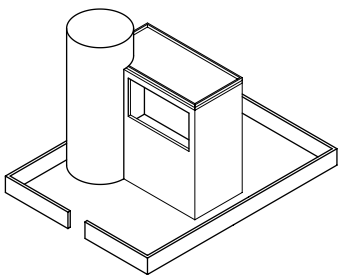
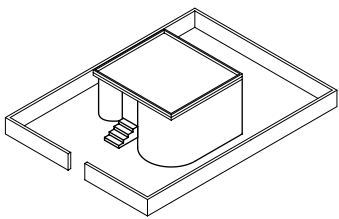
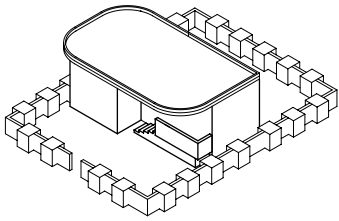

Elevations

Hanzhang Lai, Suren Sivaram,
Evan Elliot, Iris Yee

Elevations



1. Slide
2. Payphone
3. Take Me to Church
4. Chikni Chameli
5. Thank U, Next
6. Call Me Maybe
7. Waves
8. Don't Worry Be Happy

9. How to Save a Life
10. Pompeii
11. Viva La Vida
12. I'm So Tired...
13. Uma Thurman
14. Pocket Full of Sunshine
15. Castle on the Hill
16. Locked Out of Heaven

Elevations

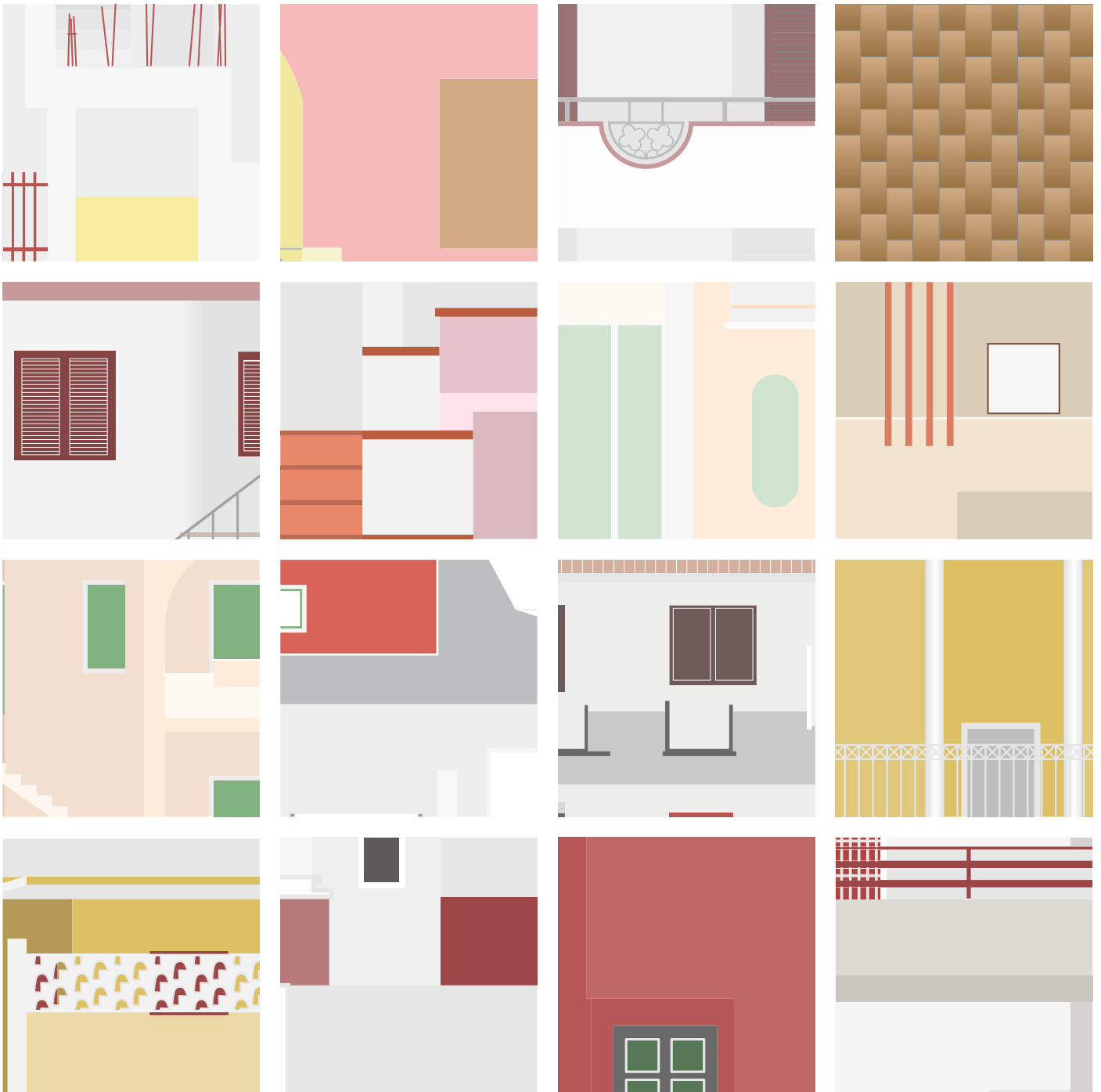

17. Where the Hood At
18. Super Bass
19. Broken
20. Cheap Ass Weave
21. You've Got a Friend in Me
22. Candy Land
23. I Took a Pill in Ibiza
24. Levels

25. Passionfruit
26. Psycho
27. Life Support
28. Thunder
29. Lemonade
30. I Need a Doctor
31. Old Town Road
32. Work

Elevations

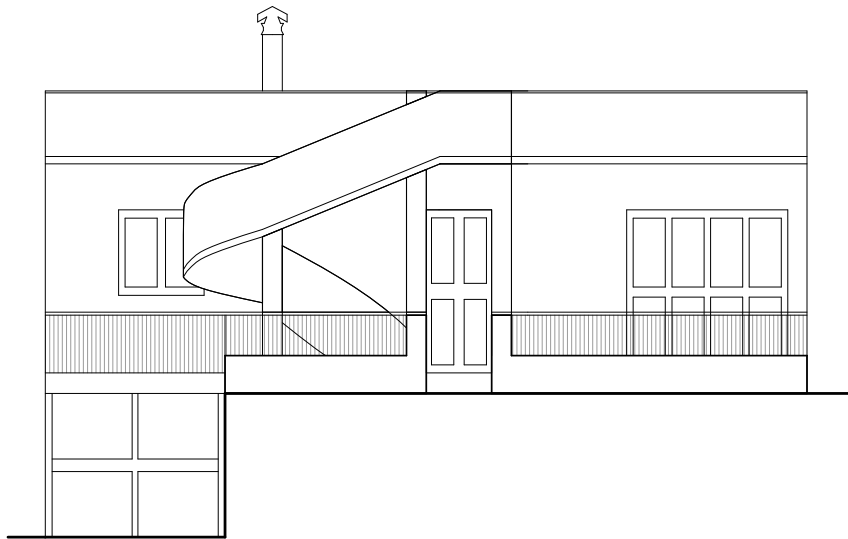

Elevations



Slide

Elevations

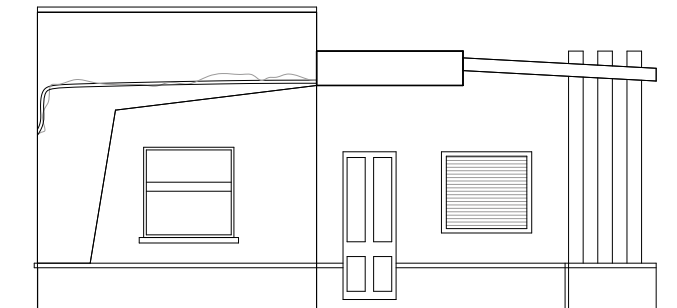

Elevations



Payphone

Elevations

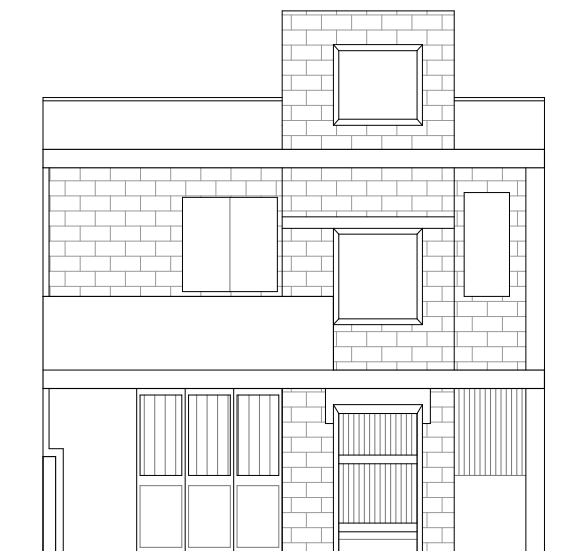

Elevations

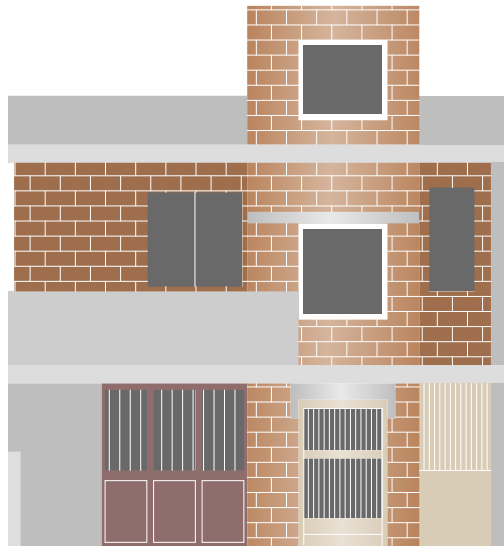

Take Me to Church

Elevations

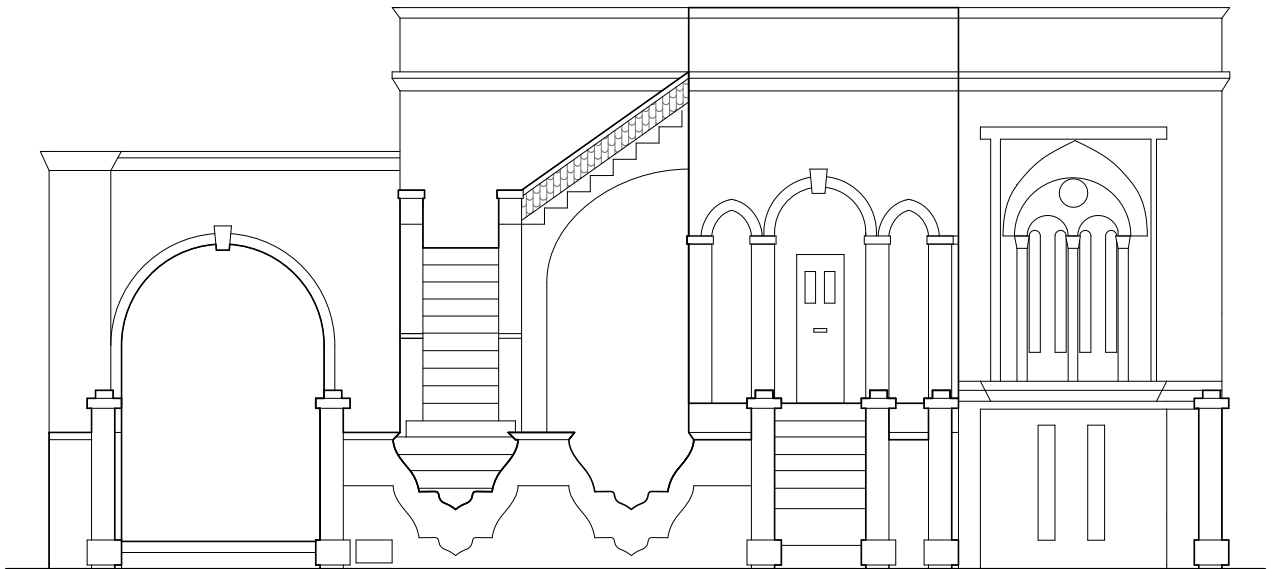

Elevations

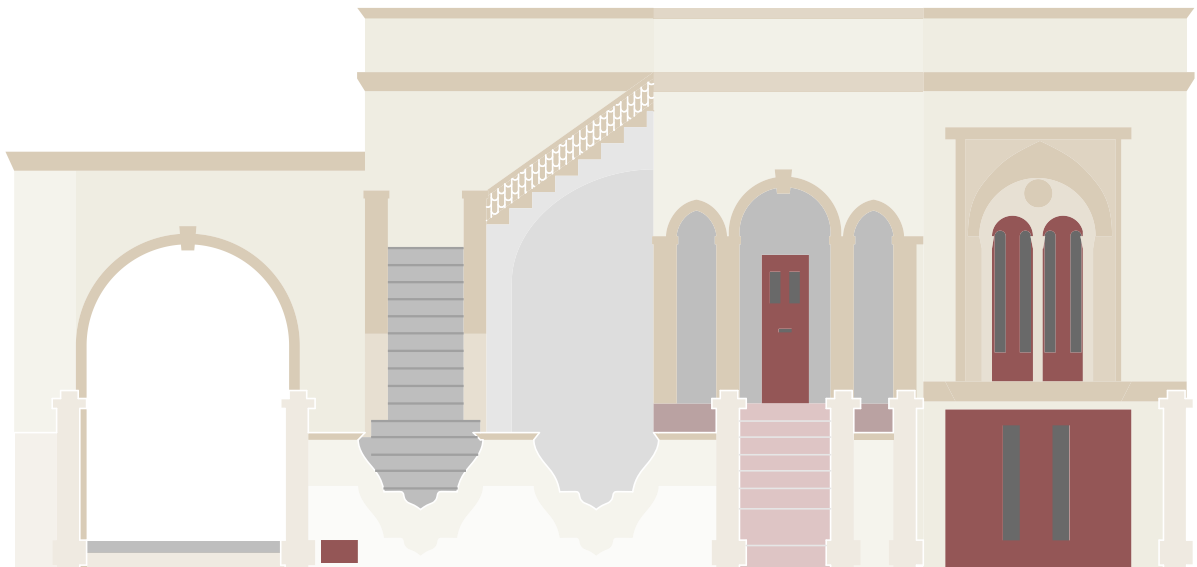

Chikni Chameli

Elevations

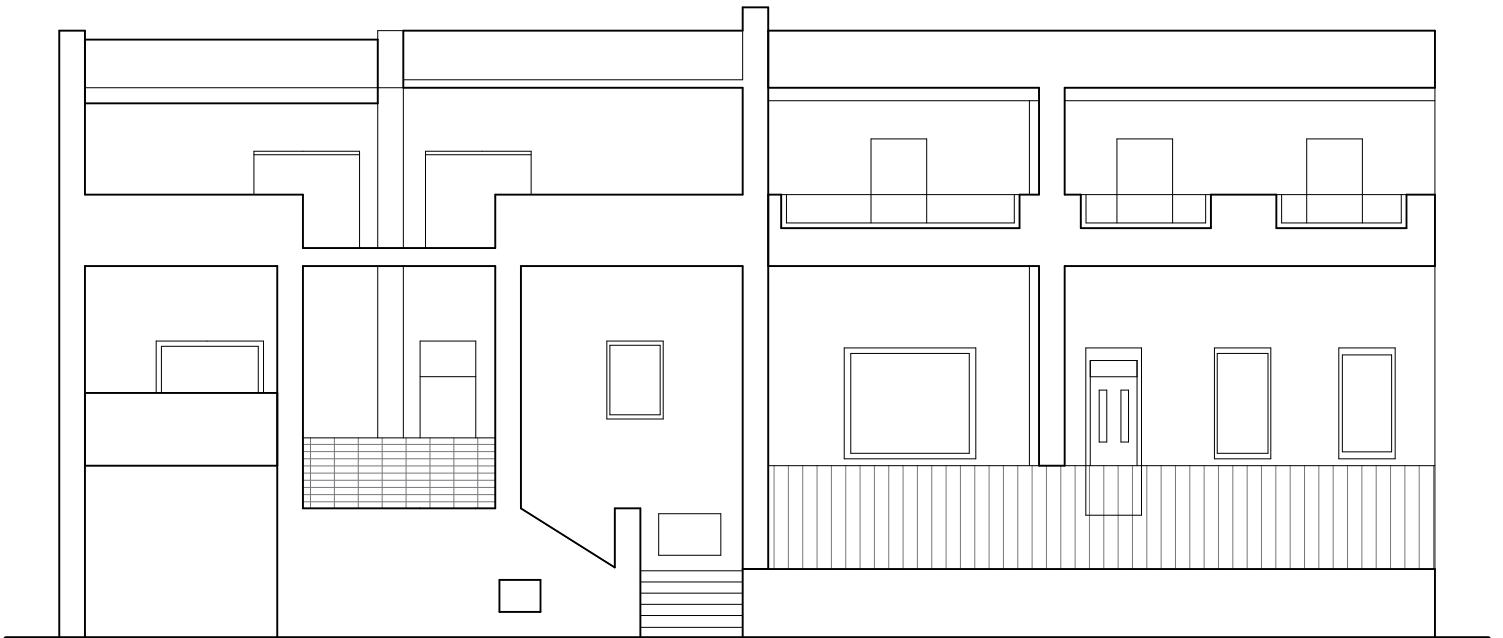

Elevations

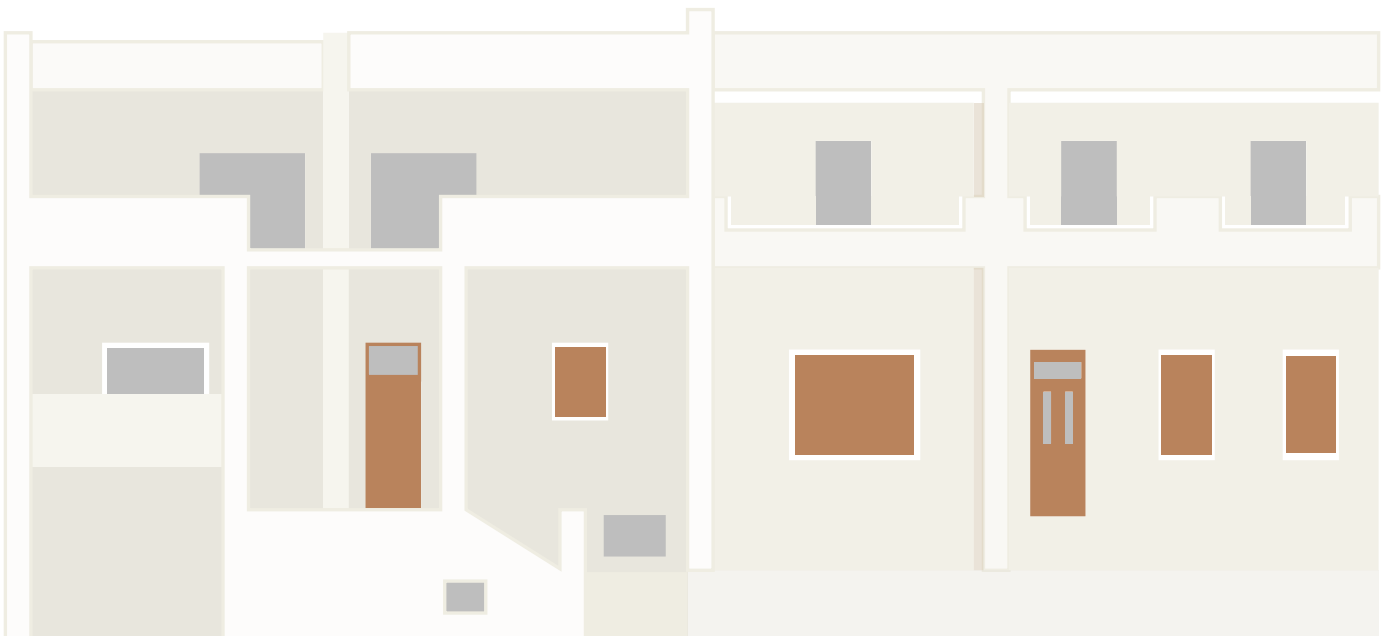

Thank U, Next

Elevations

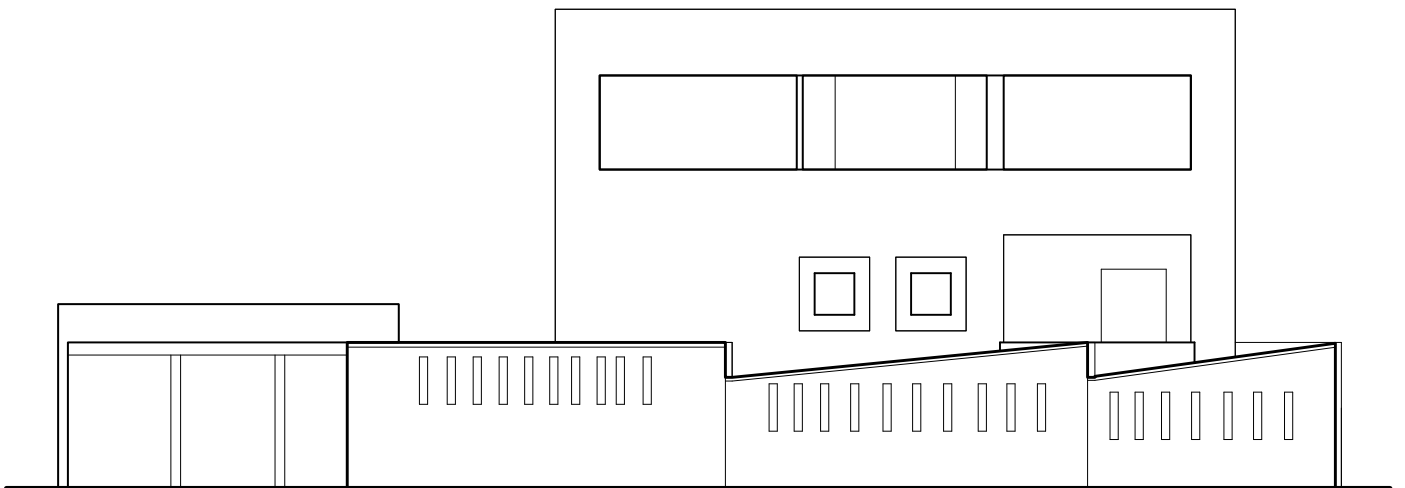

Elevations

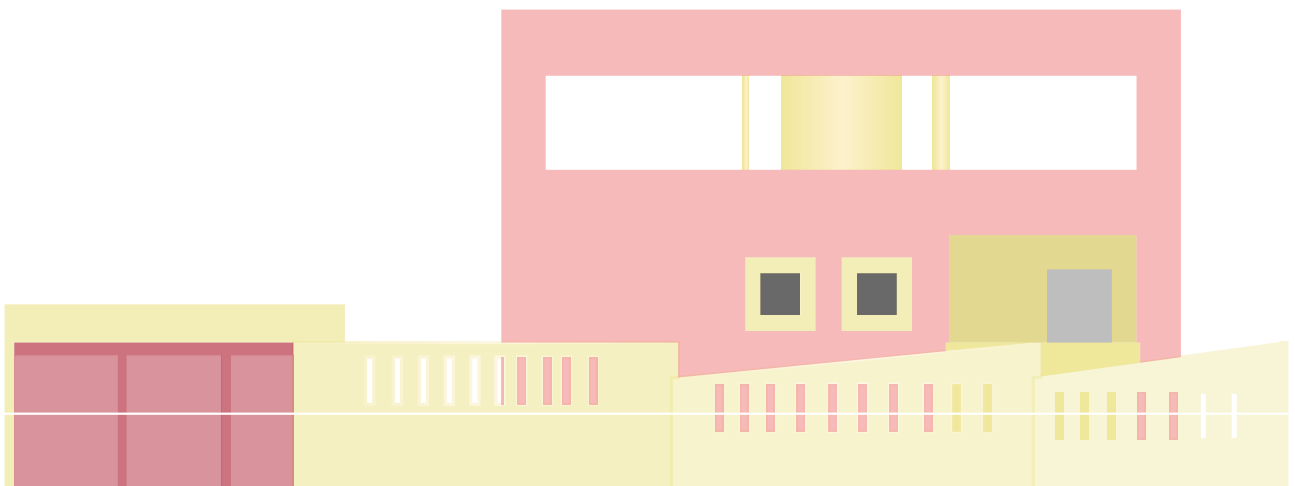

Call Me Maybe

Elevations

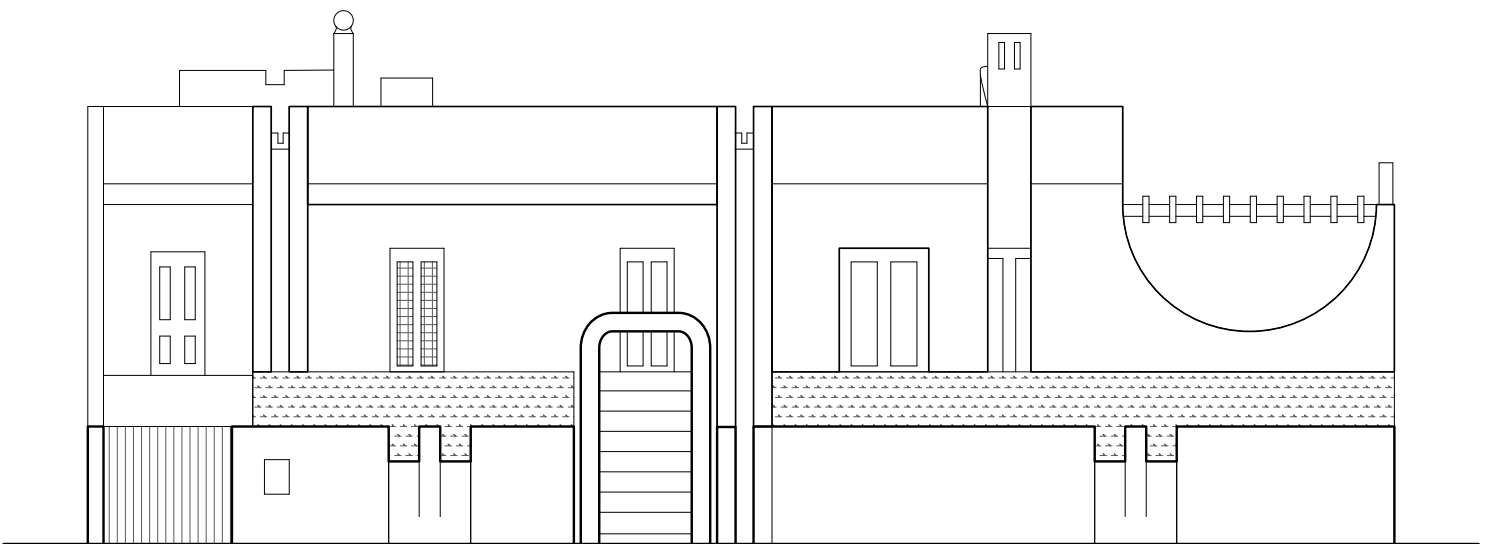

Elevations

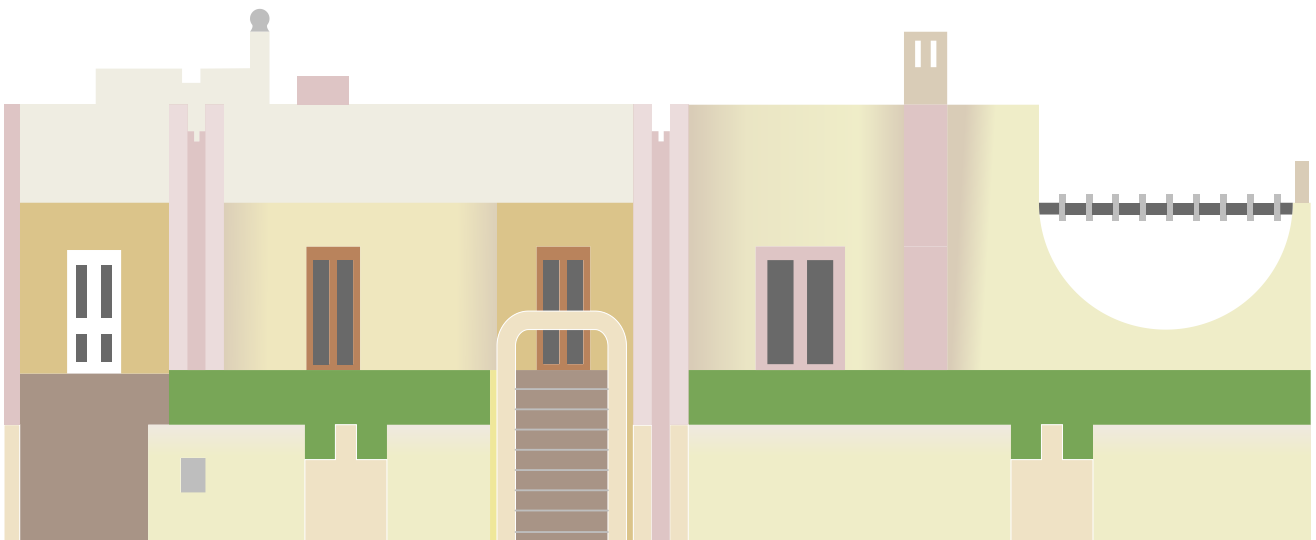

Waves

Elevations

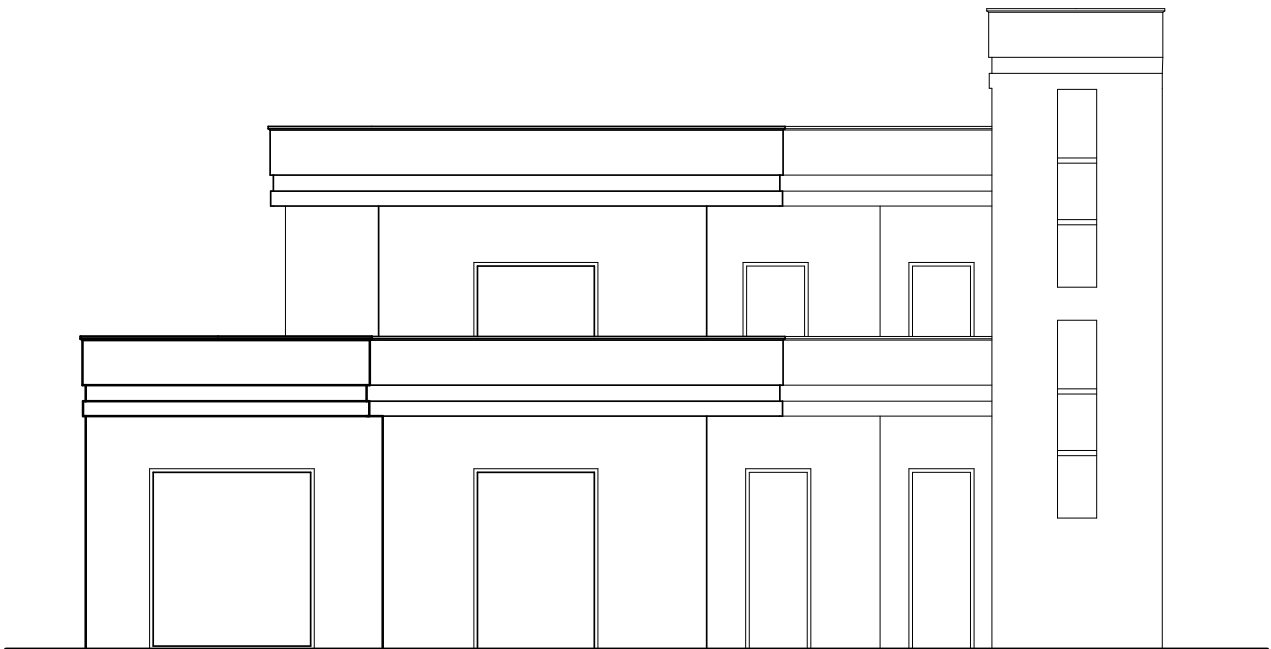

Elevations

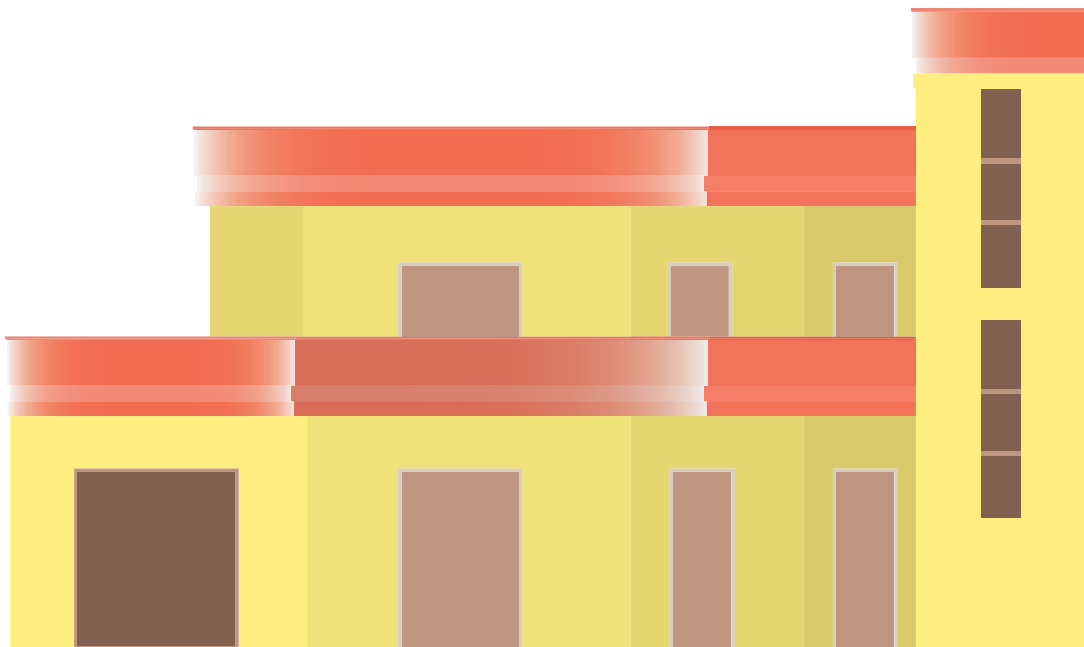

Don't Worry Be Happy

Elevations

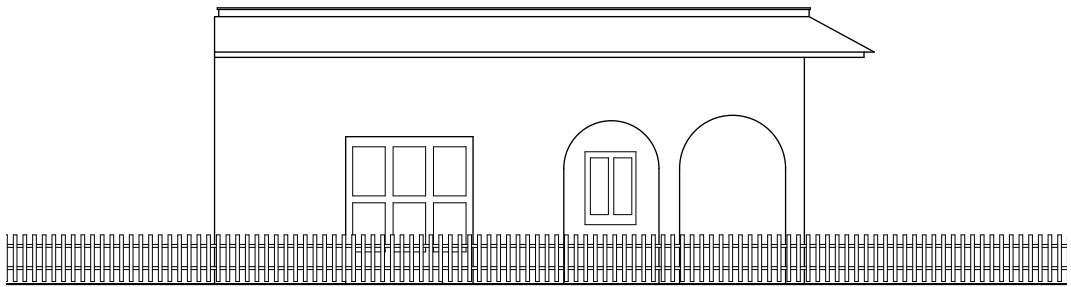

Elevations

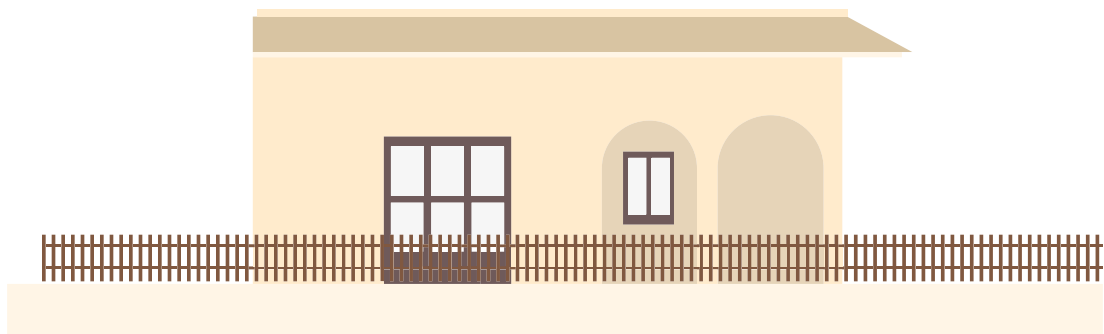

Elevations

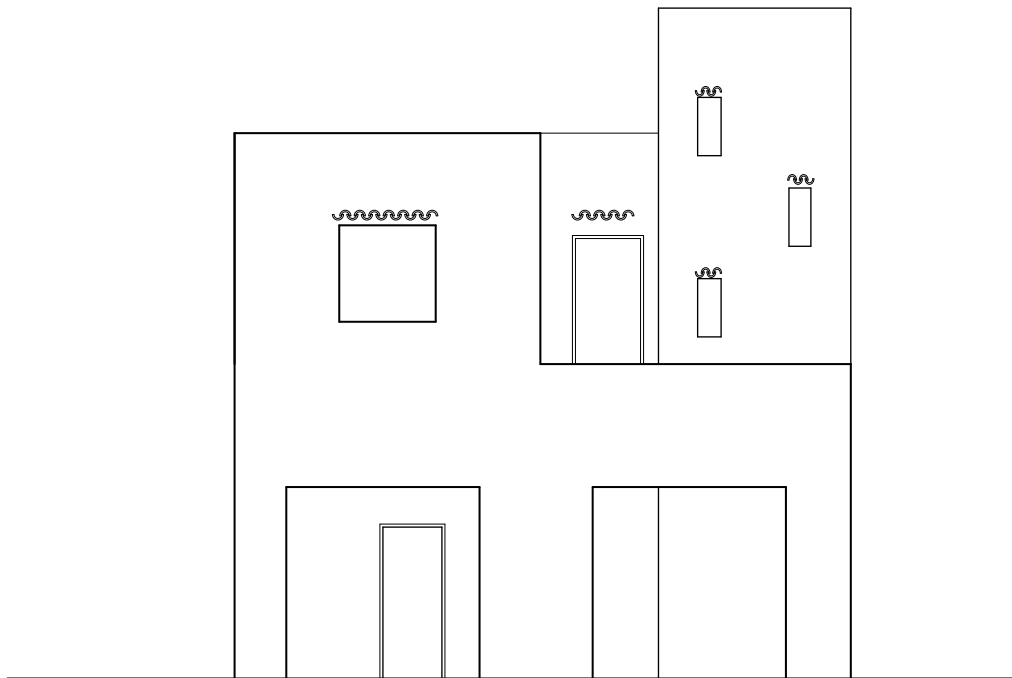

Elevations

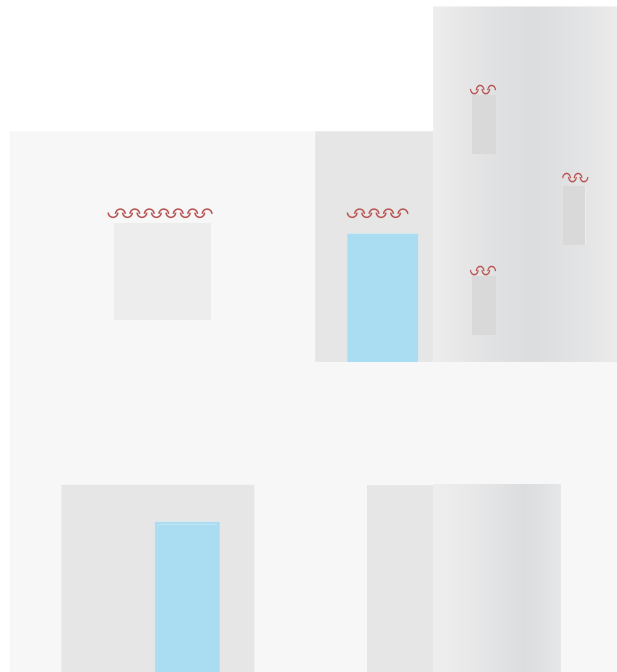

Pompeii

Elevations

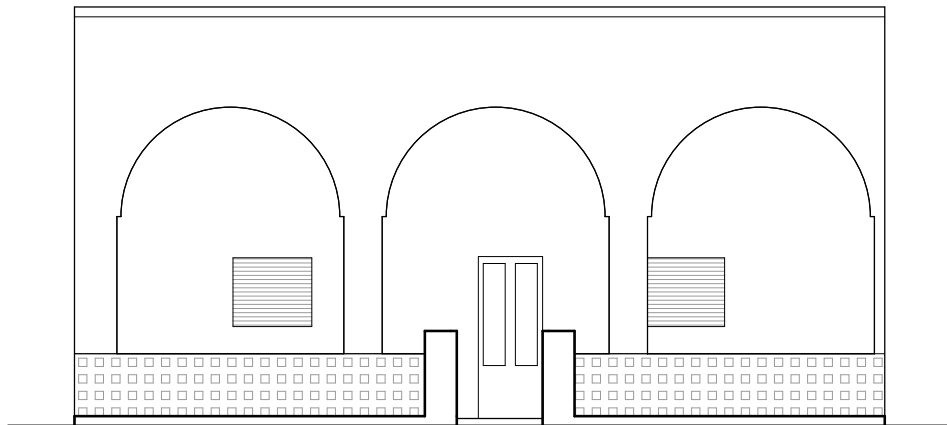

Elevations

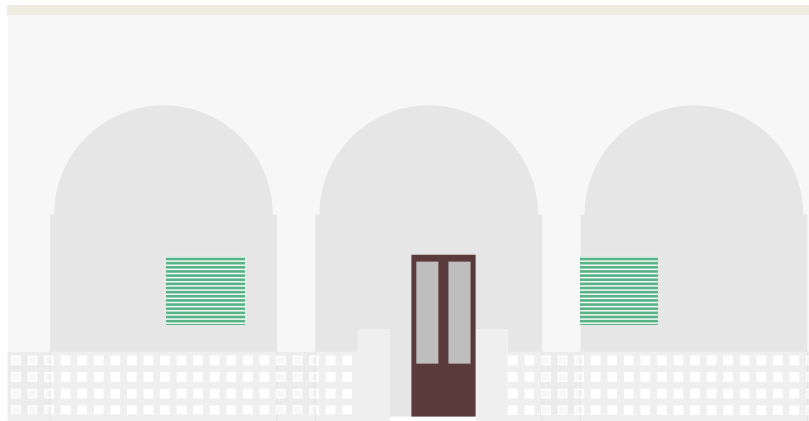

Viva La Vida

Elevations

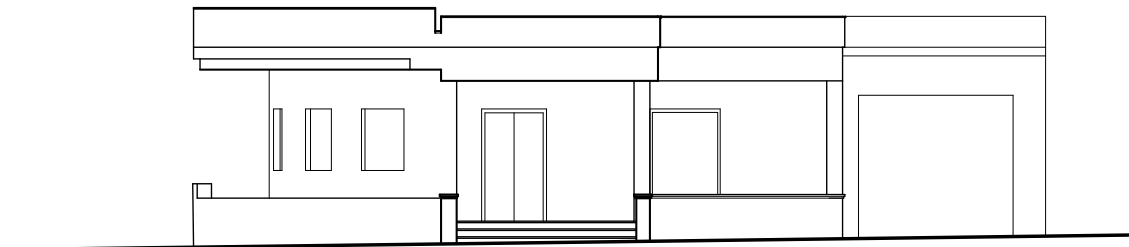

Elevations

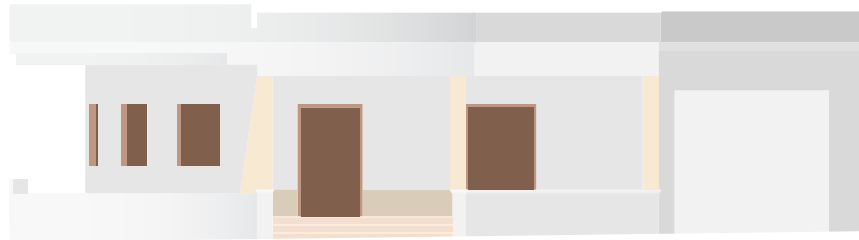

I'm So Tired...

Elevations

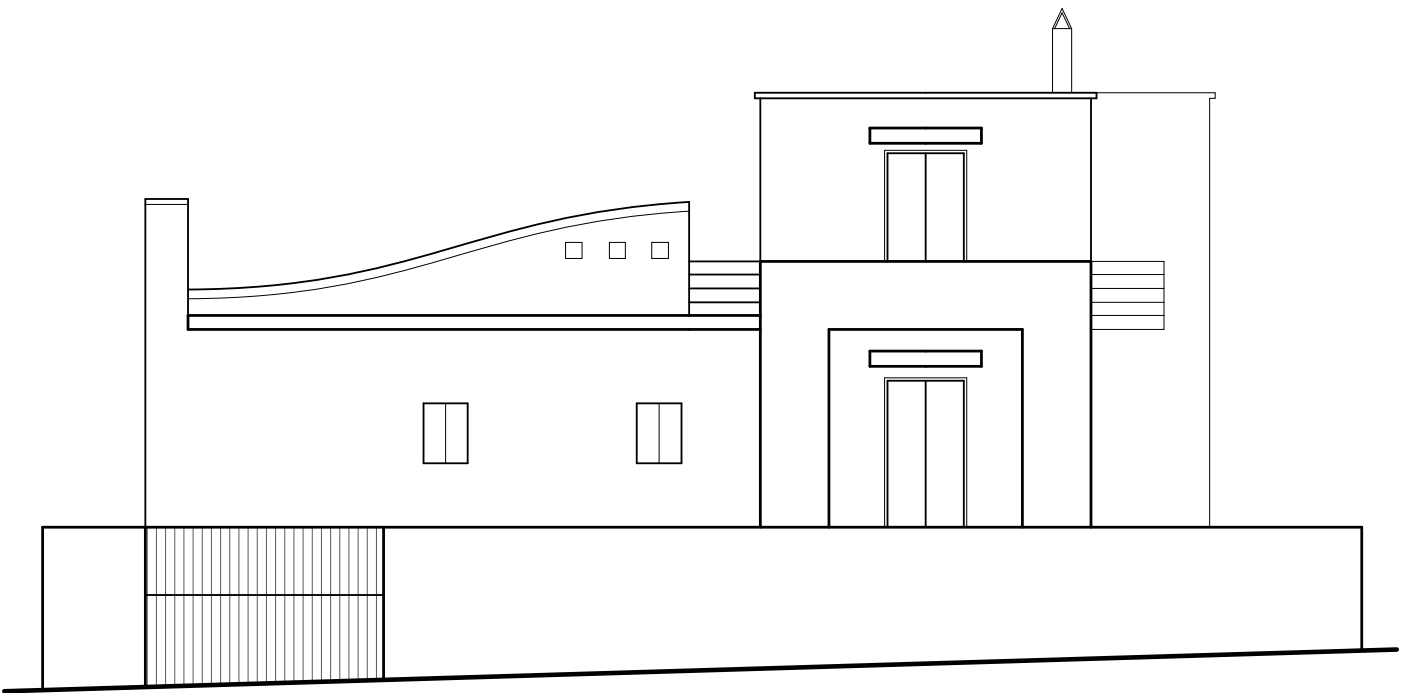

Elevations

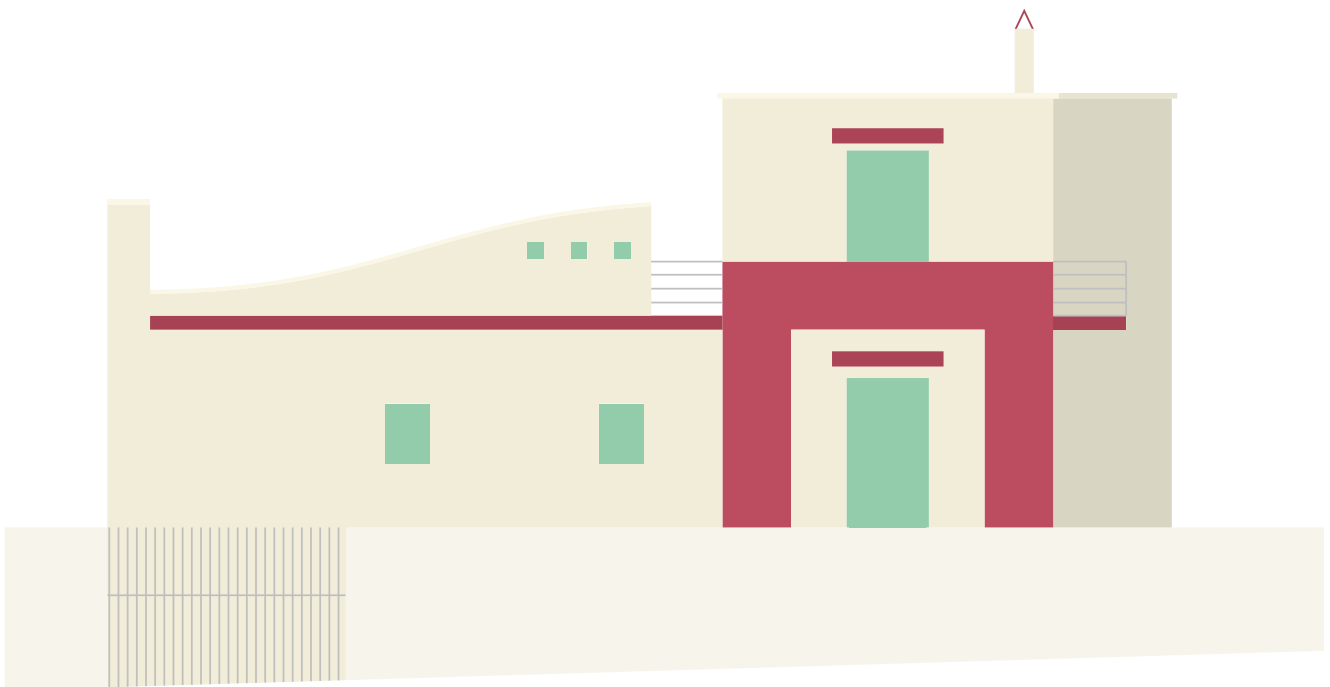

Uma Thurman

Elevations

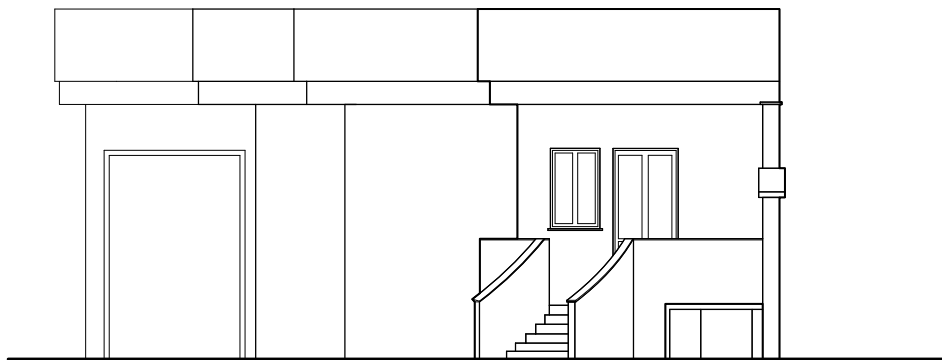

Elevations



Pocket Full of Sunshine

Elevations

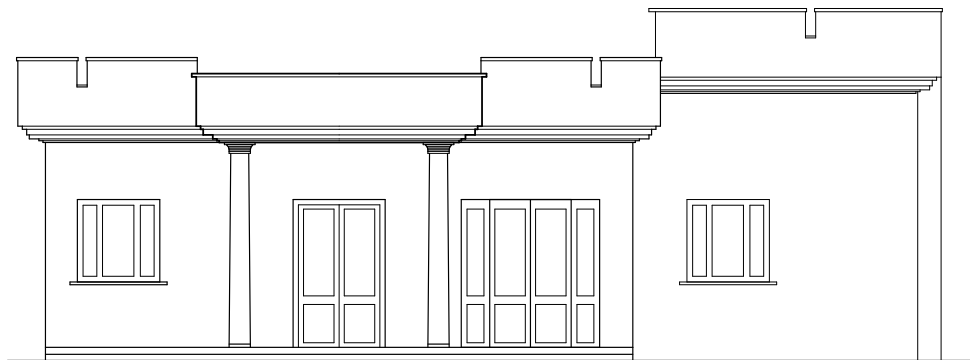

Elevations



Castle on the Hill

Elevations

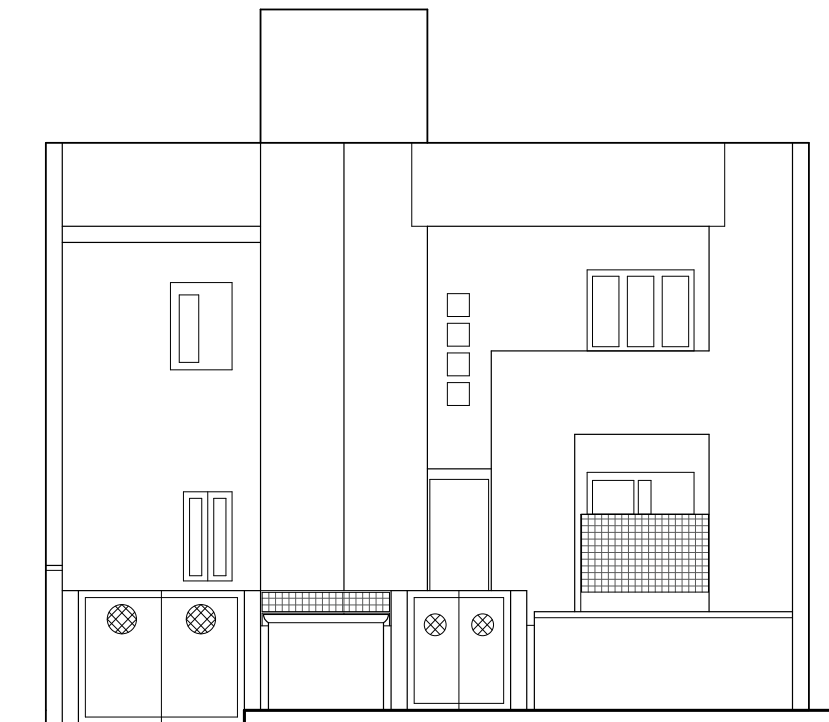

Elevations

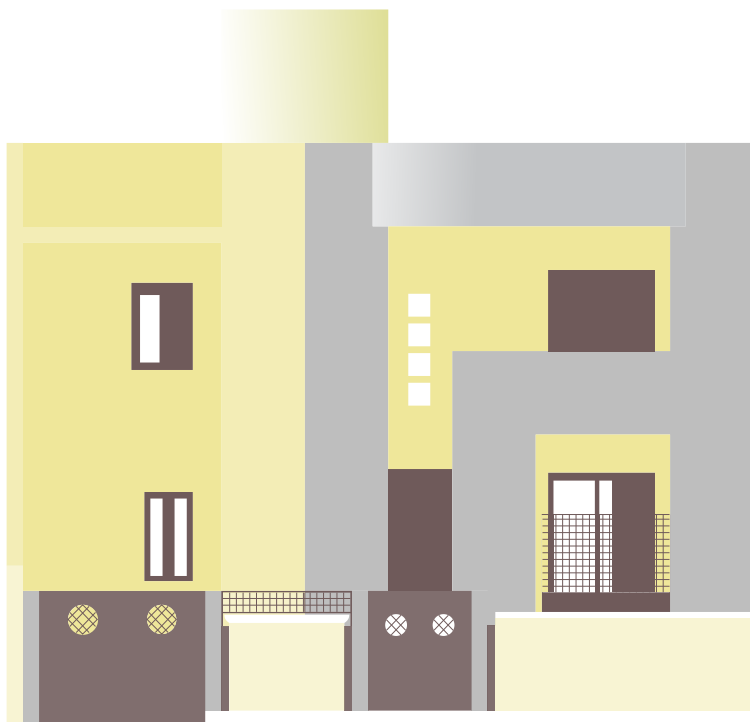

Locked Out of Heaven

Elevations

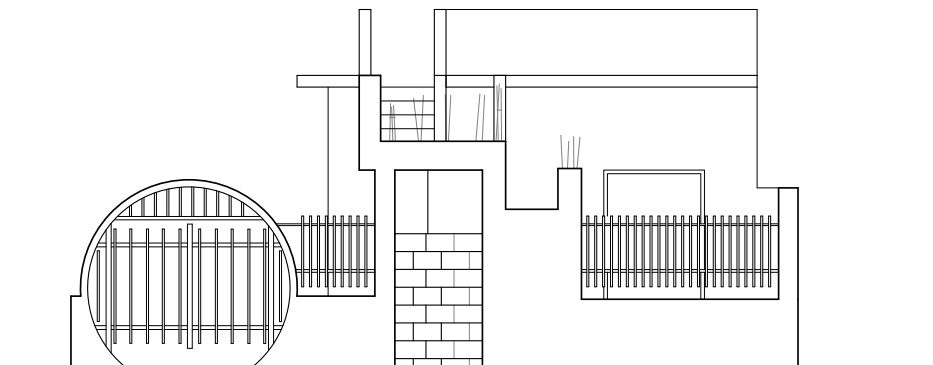

Elevations

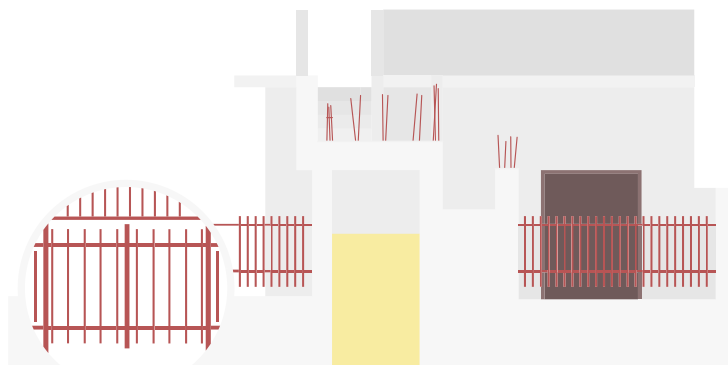

Where the Hood At

Elevations

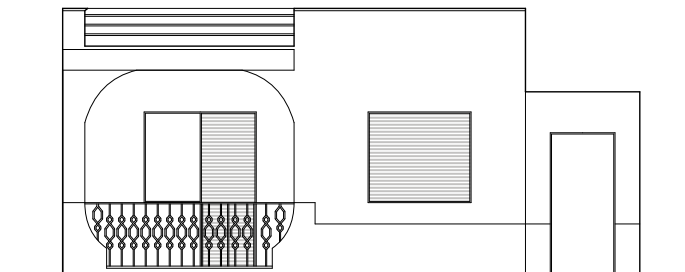

Elevations

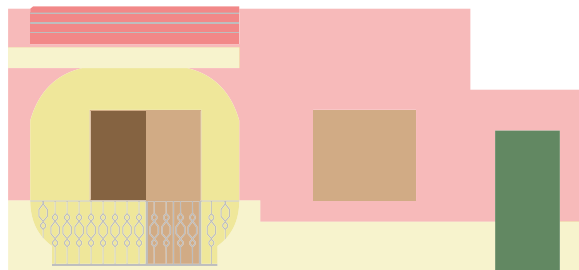

Super Bass

Elevations



Elevations

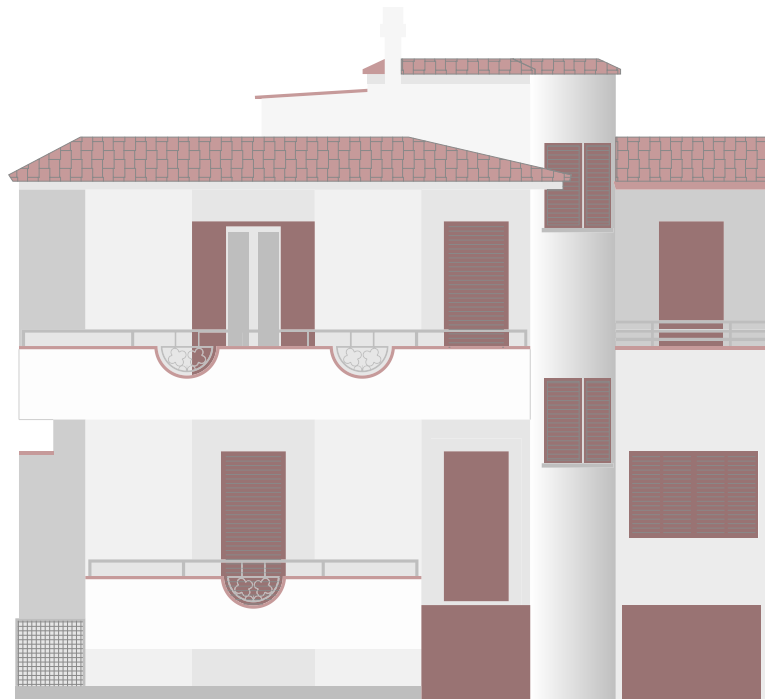

Broken

Elevations

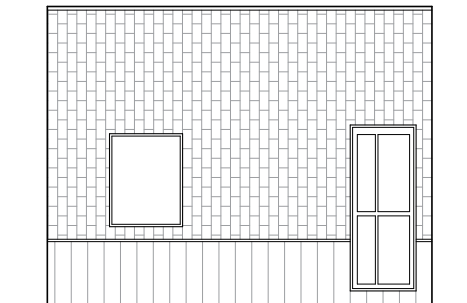

Elevations

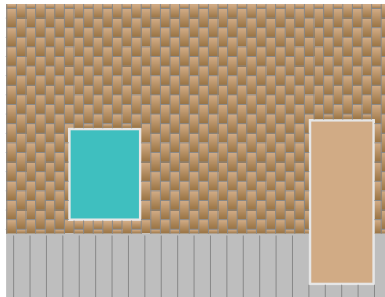

Cheap Ass Weave

Elevations

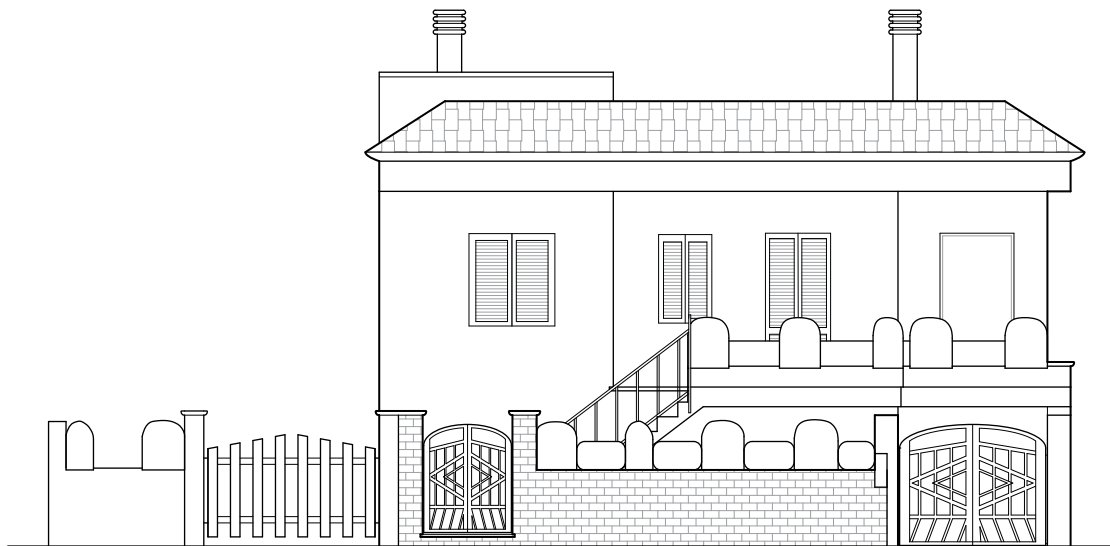

Elevations

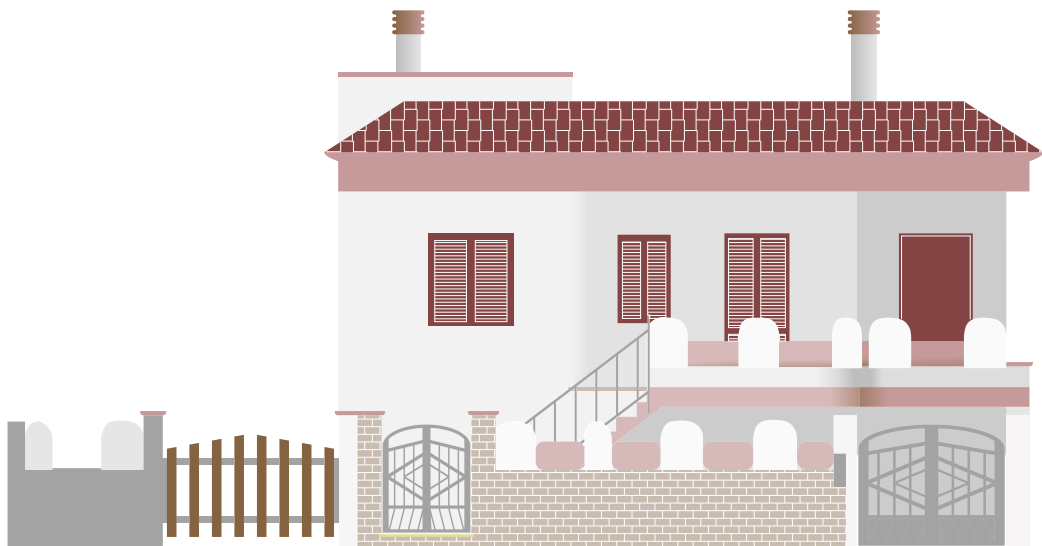

You've Got a Friend in Me

Elevations

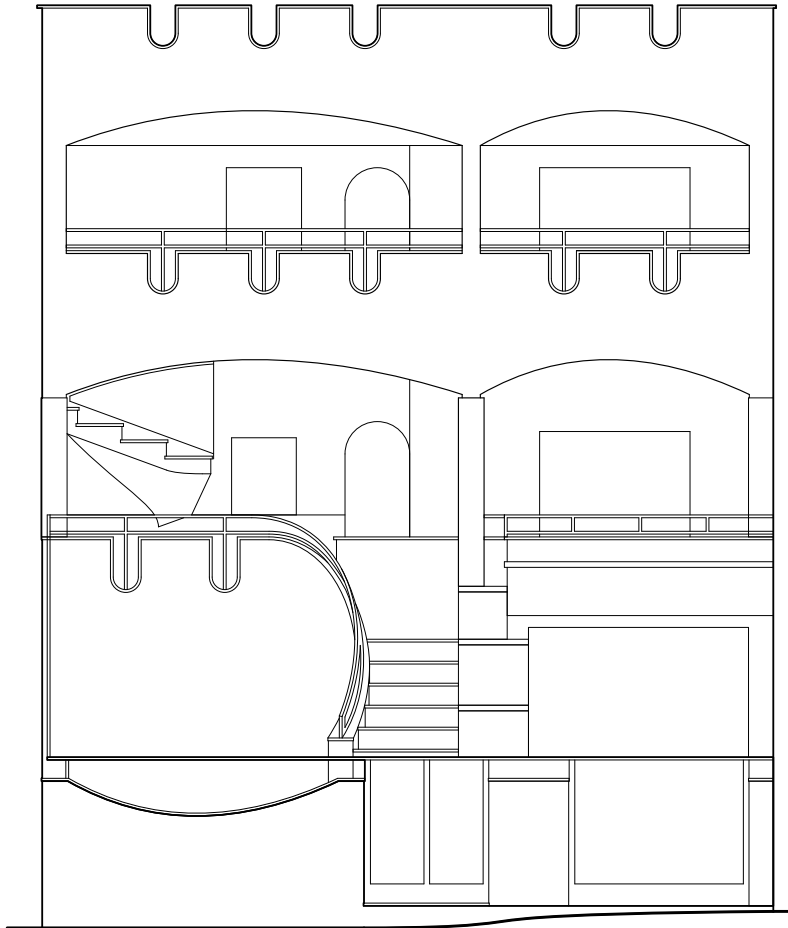

Elevations

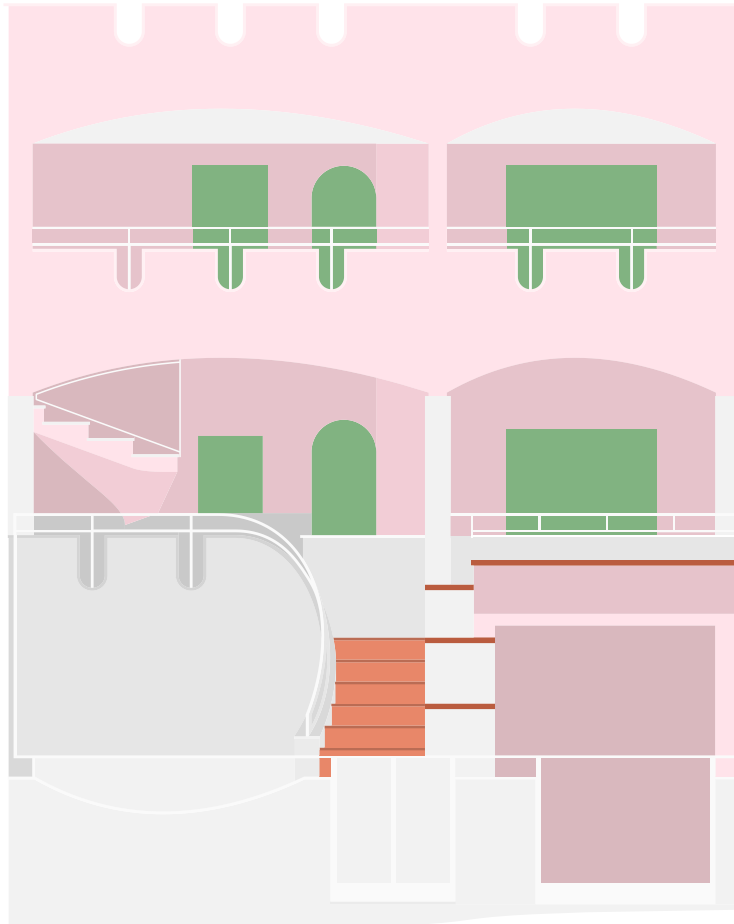

Candy Land

Elevations

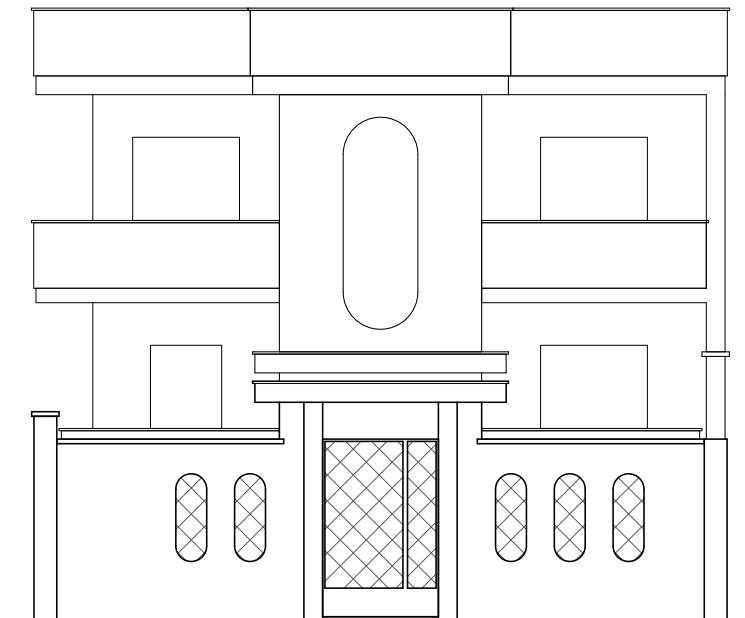

Elevations

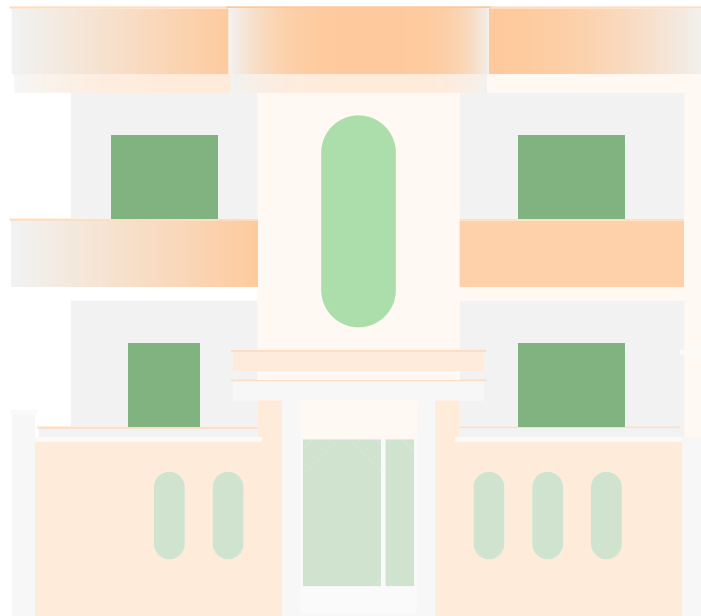

I Took a Pill in Ibiza

Elevations

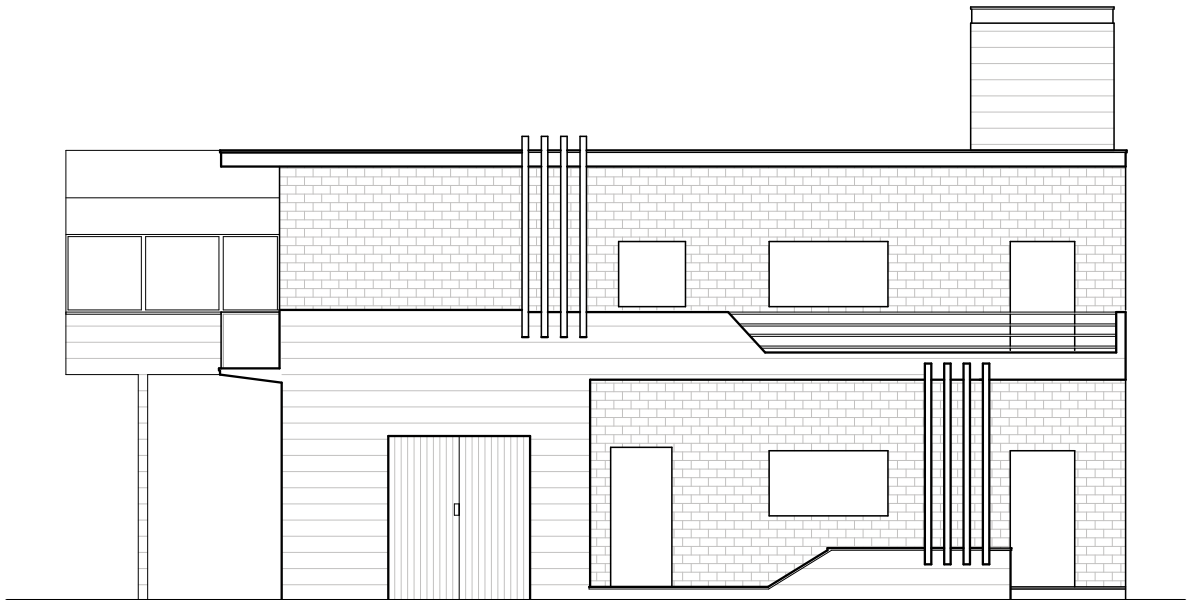

Elevations

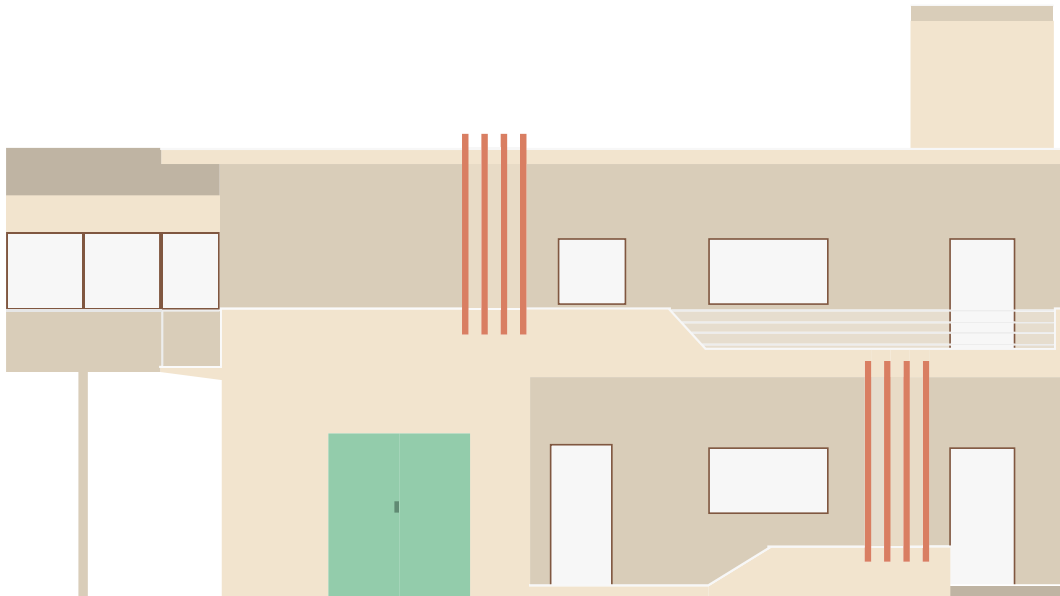

Levels

Elevations

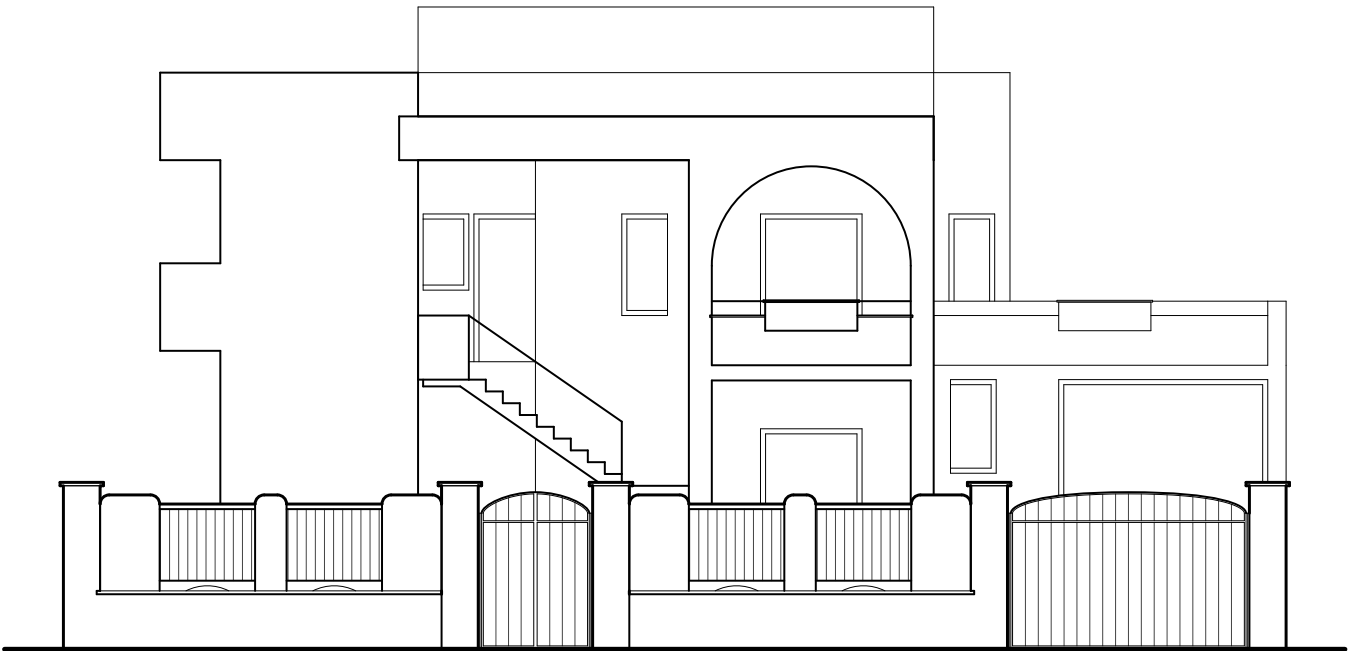

Elevations

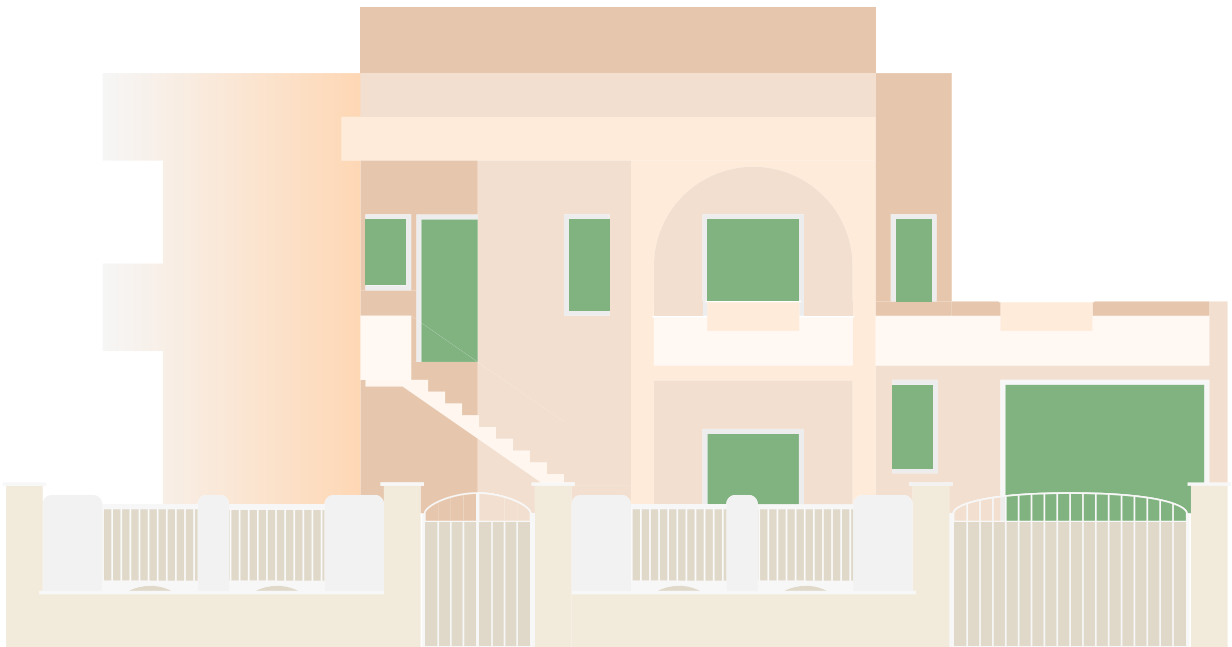

Passionfruit

Elevations

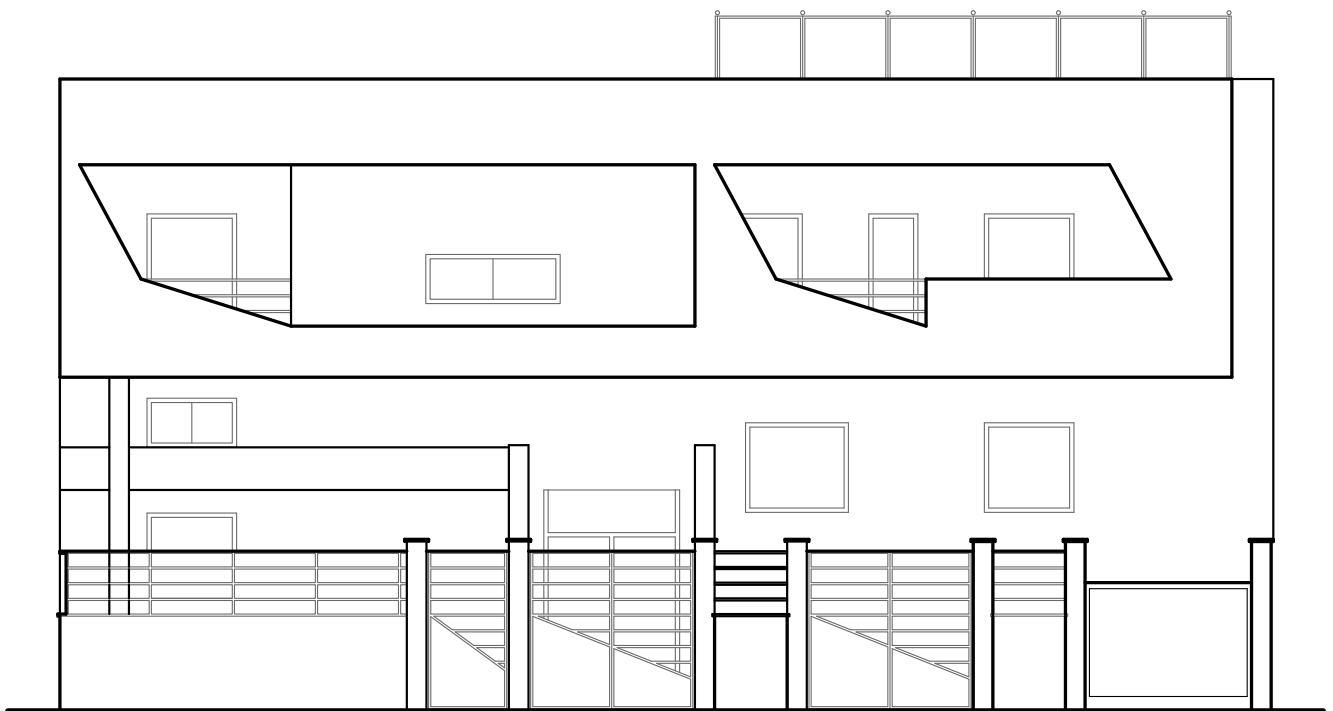

Elevations

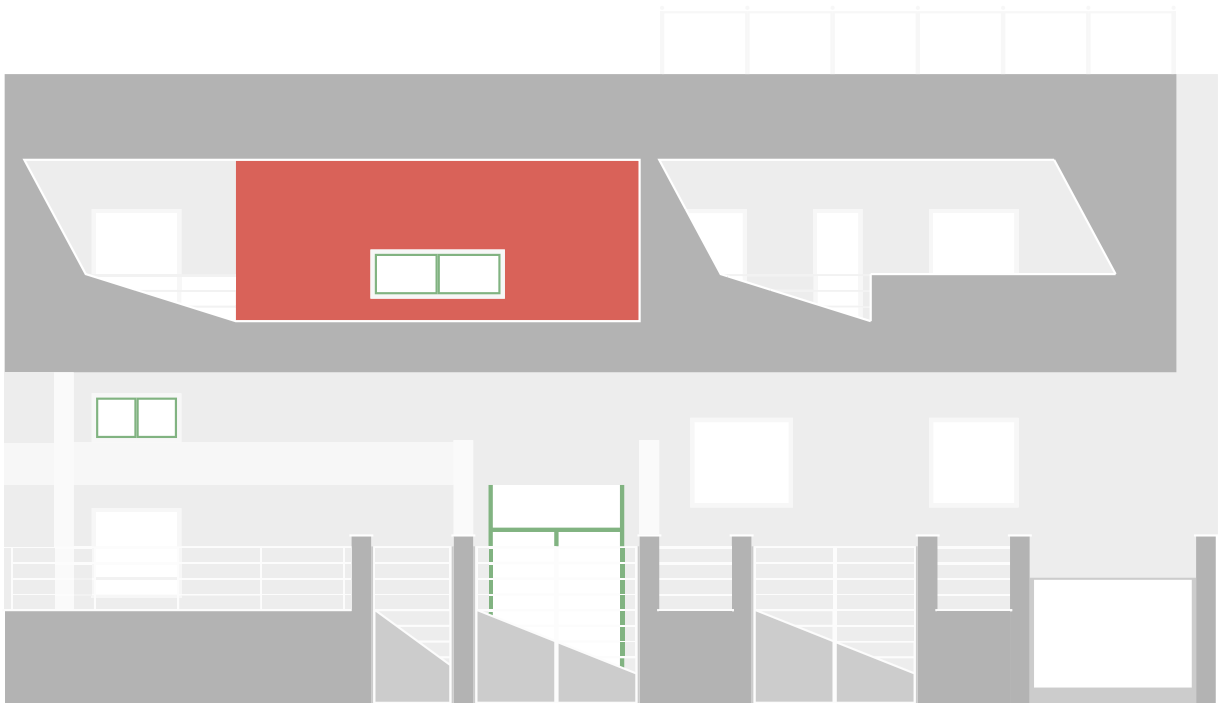

Psycho

Elevations

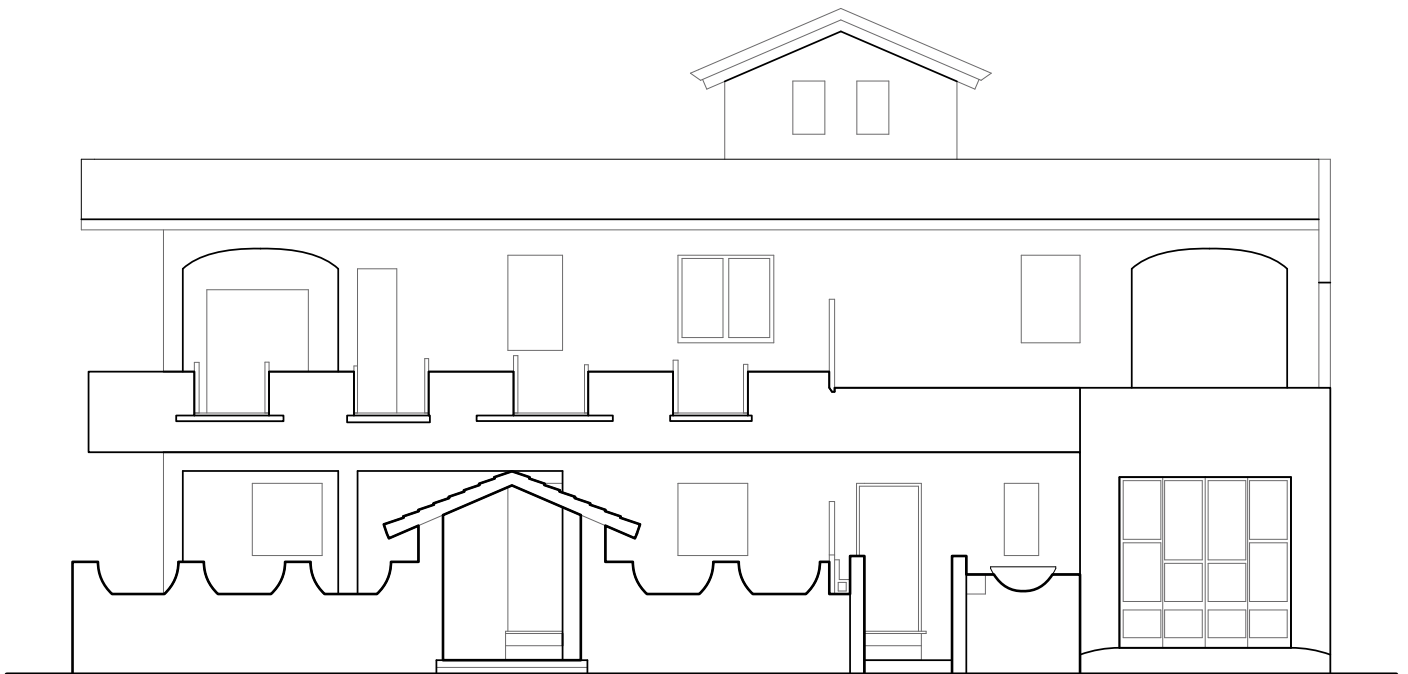

Elevations

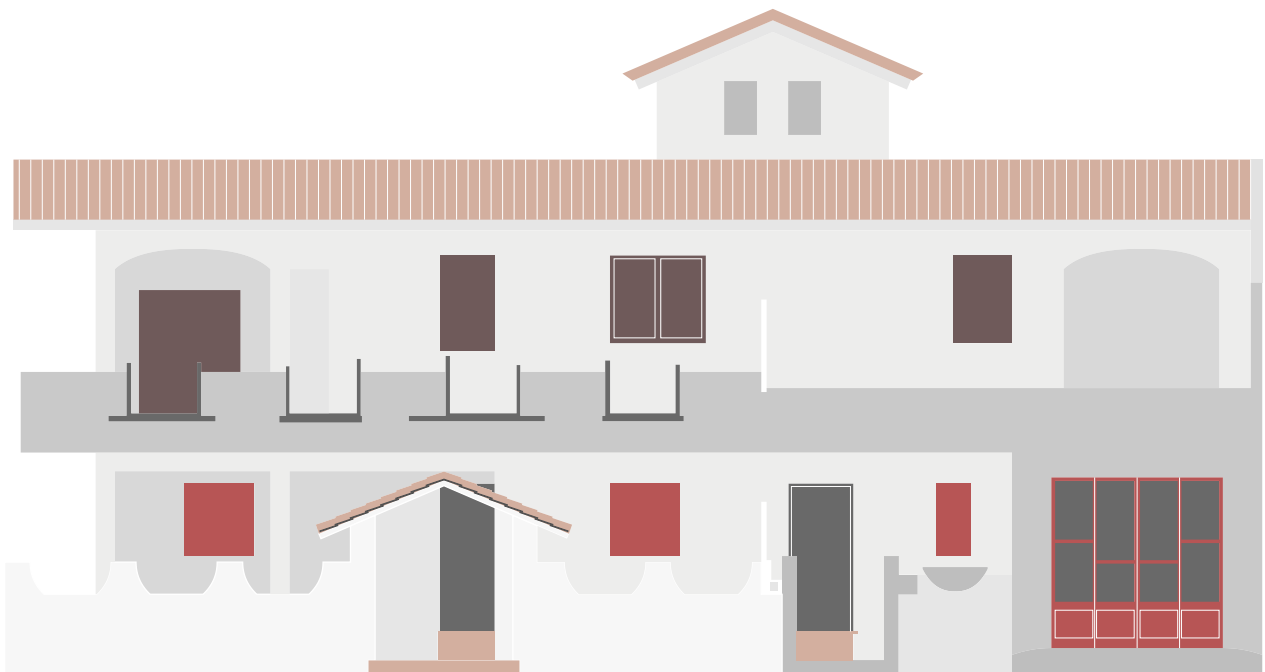

Life Support

Elevations

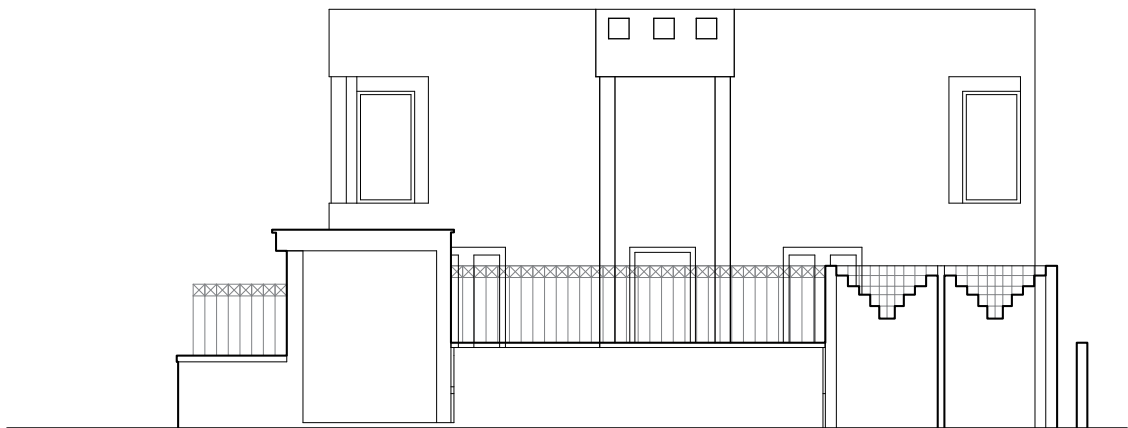

Elevations



Thunder

Elevations

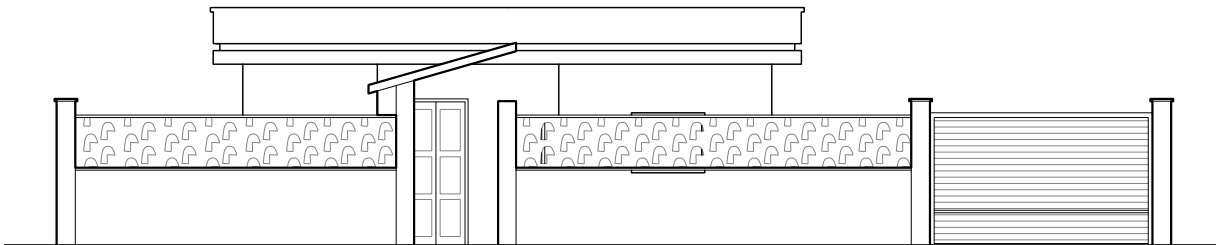

Elevations

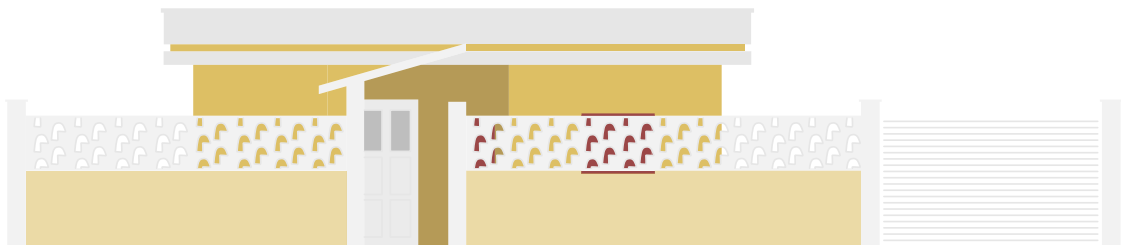

Lemonade

Elevations

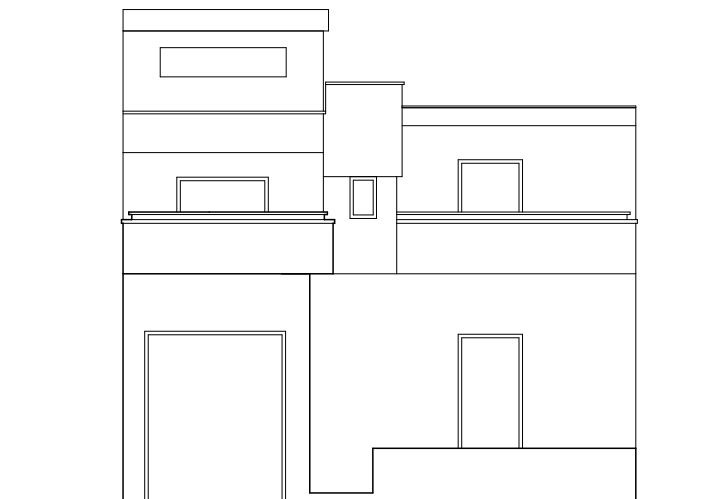

Elevations

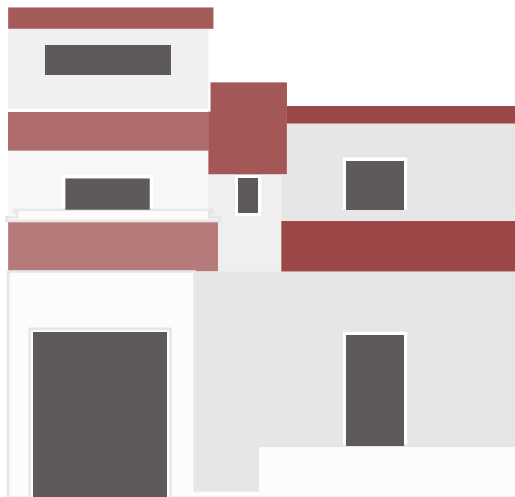

I Need a Doctor

Elevations



Elevations

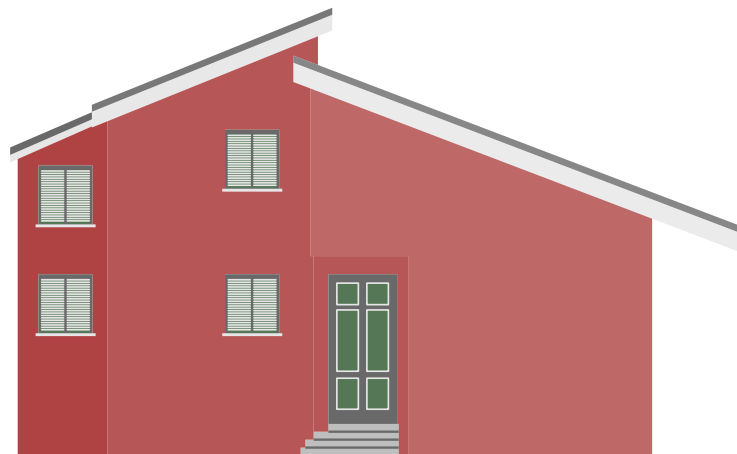

Old Town Road

Elevations

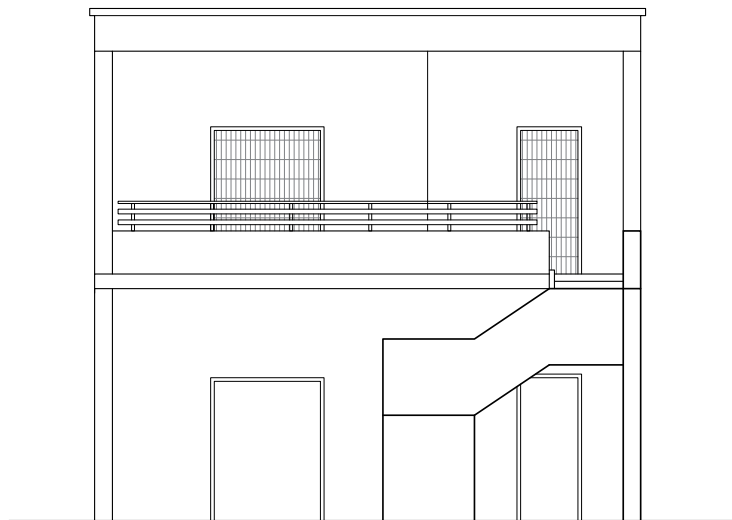

Elevations

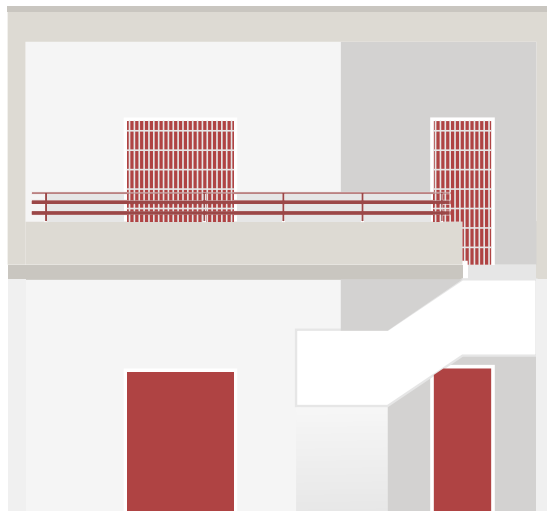

Work

Site Plan

David Acevedo, Bryan Cordova,
Jack Hymowitz, Shaan
Lakshmanan

Site Plan

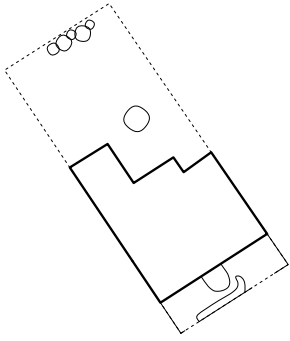

#007

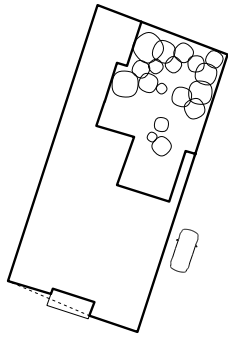

#005

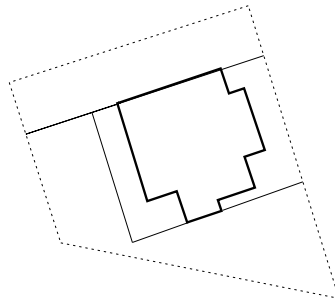

#020

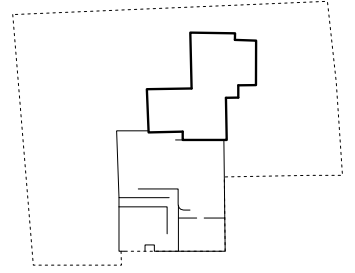

#026

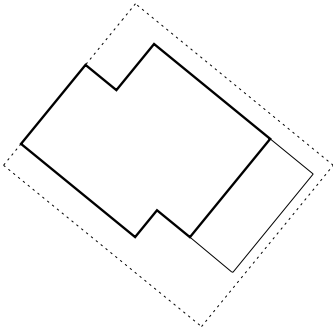

#066

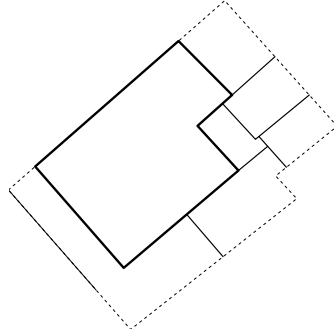

#071

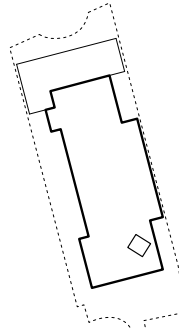

#099

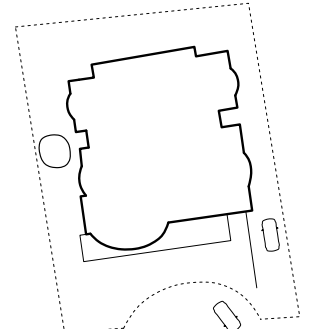

#107

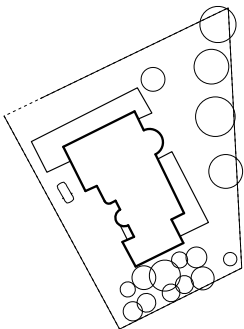

#152

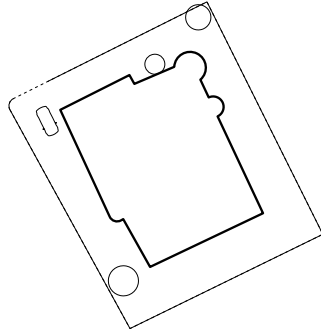

#154

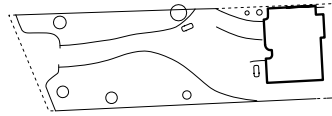

#168

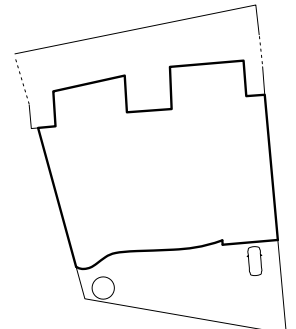

#176

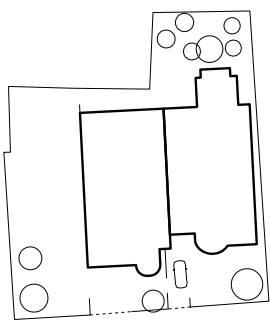

#224

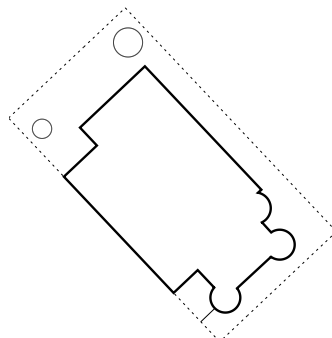

#230

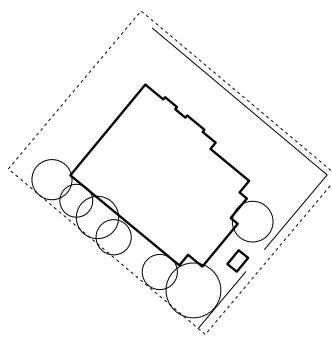

#423

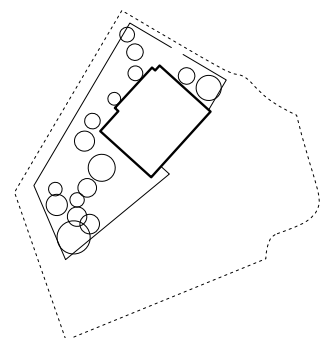

#428

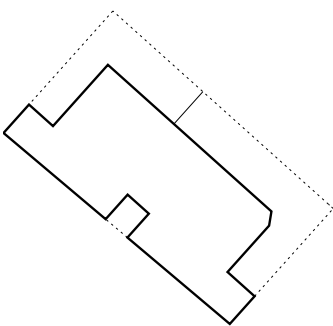

#461

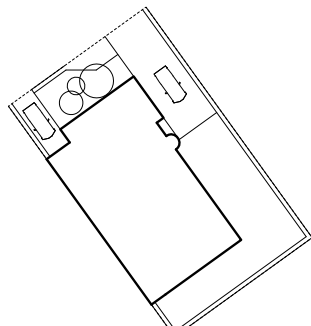

#476

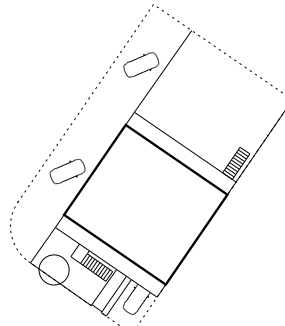

#483

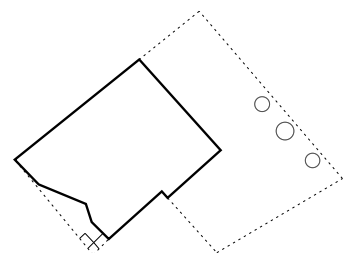

#484

Site Plan

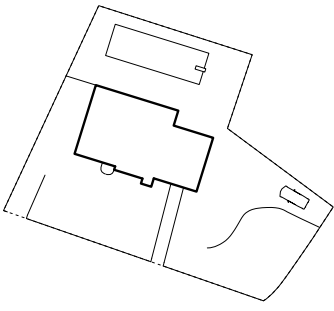

#028

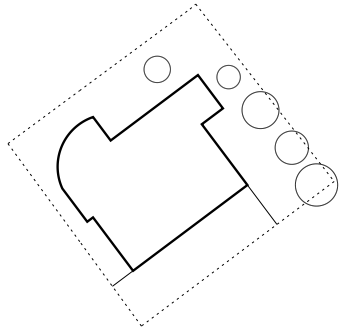

#032

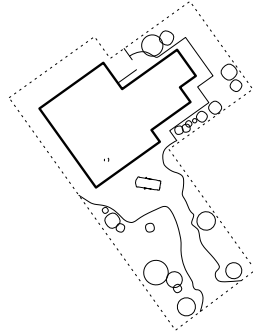

#033

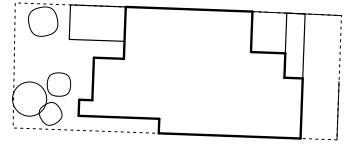

#047

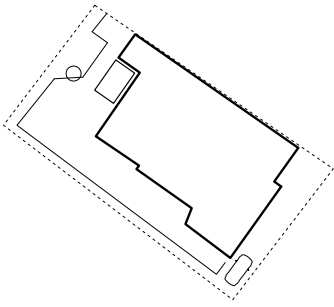

#117

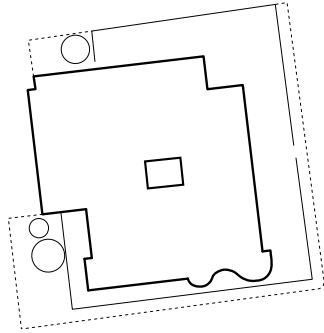

#134

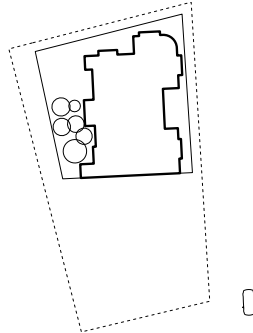

#142

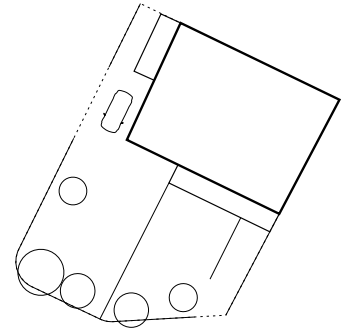

#145

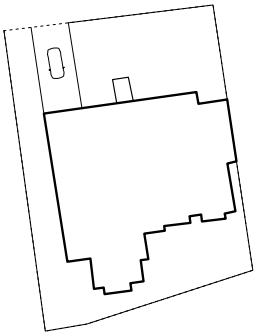

#189

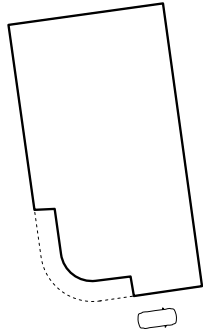

#190

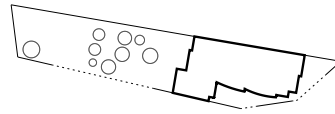

#193

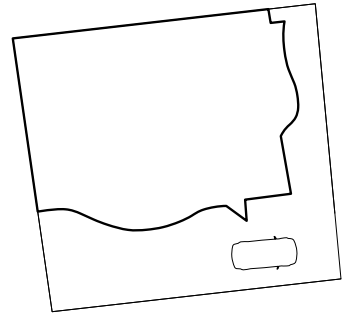

#197

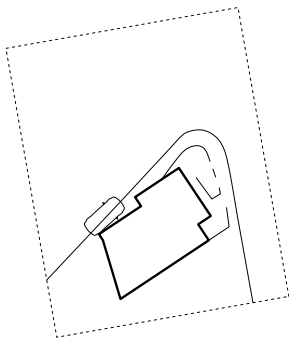

#450

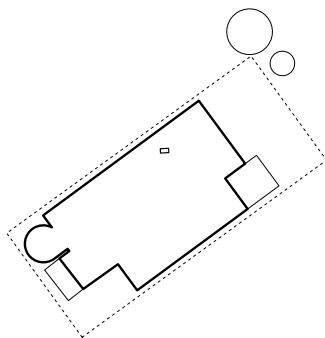

#451

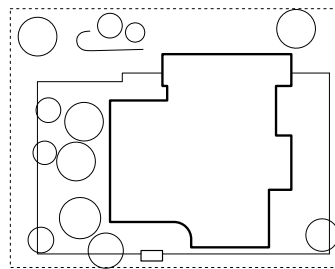

#456

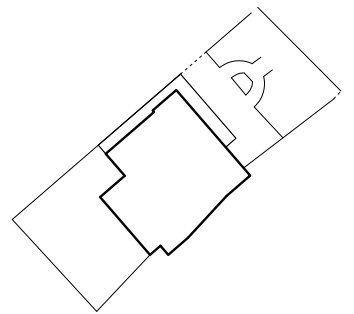

#460

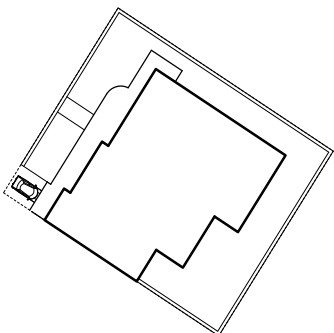

#487

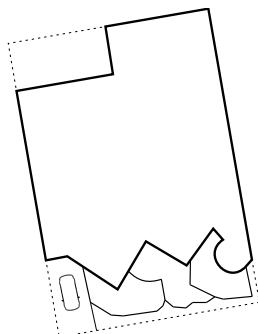

#492

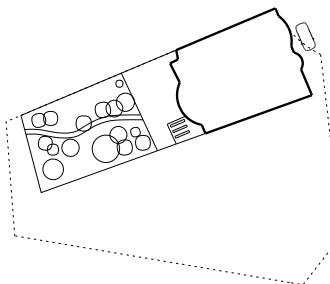

#494

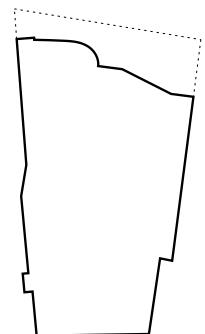

#499

Site Plan

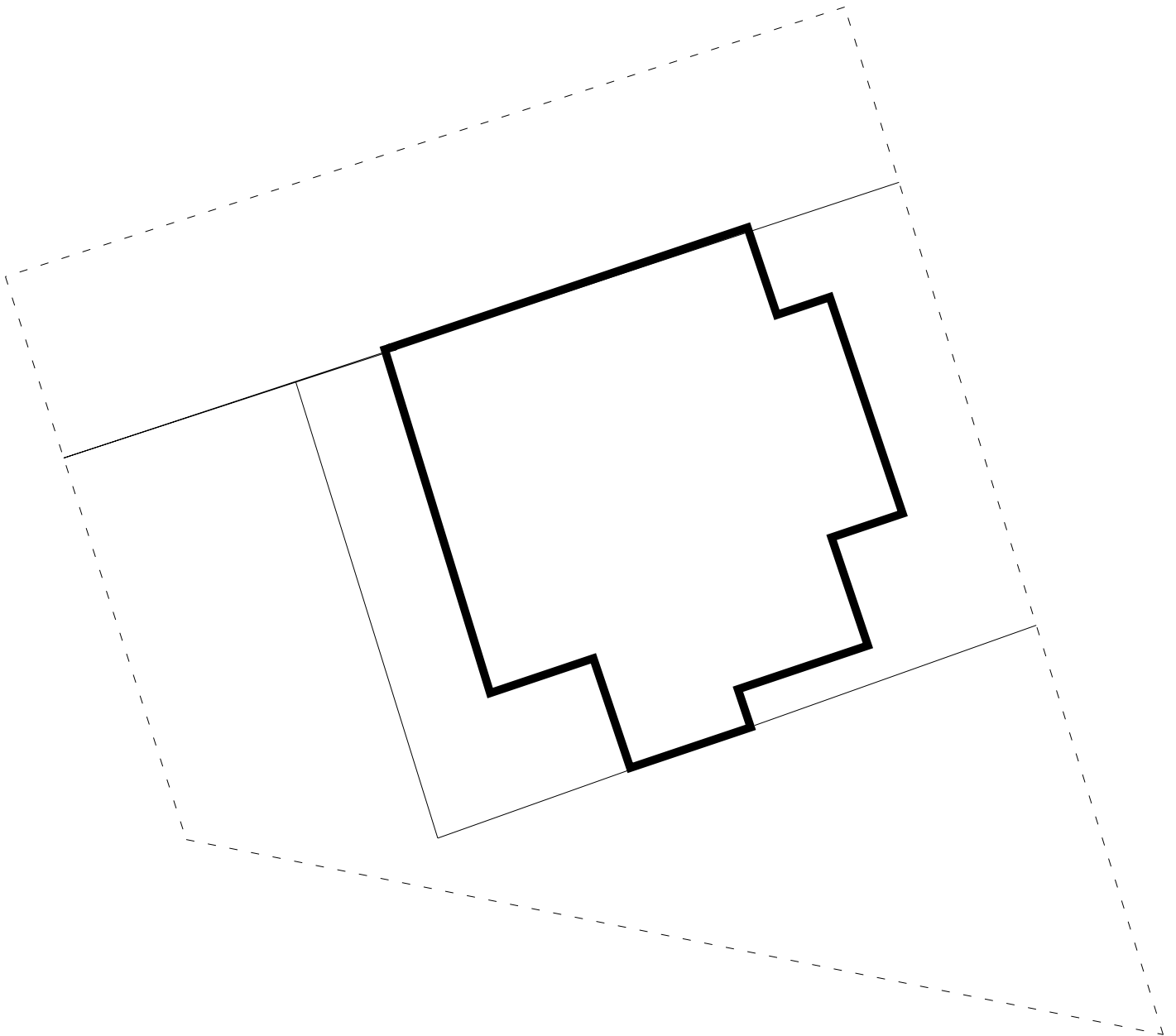

#020 - Acquarica del Capo - Via de Fillippo

Orientation

Attached Semi Detached

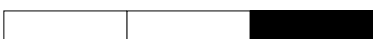

Shape

Box Curvy Geometric



Yard

Front Back None



Borders

Fence Wall None



Parking

Drive Street None



Stairs

Yes No



Site Plan

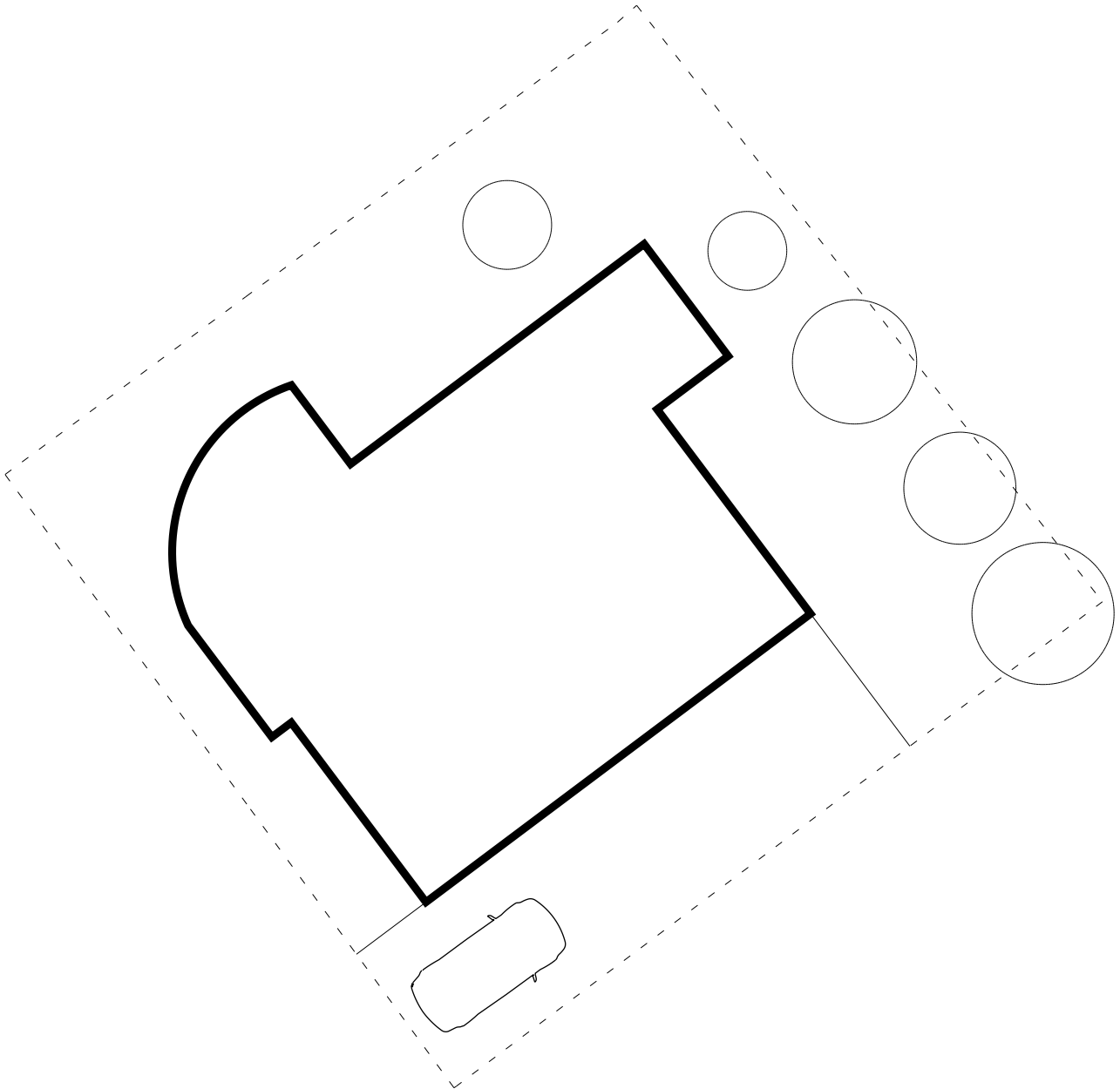

#032 - Alessano - Via G. Di vittoria

Orientation

Attached Semi Detached



Shape

Box Curvy Geometric



Yard

Front Back None



Borders

Fence Wall None



Parking

Drive Street None



Stairs

Yes No



Site Plan

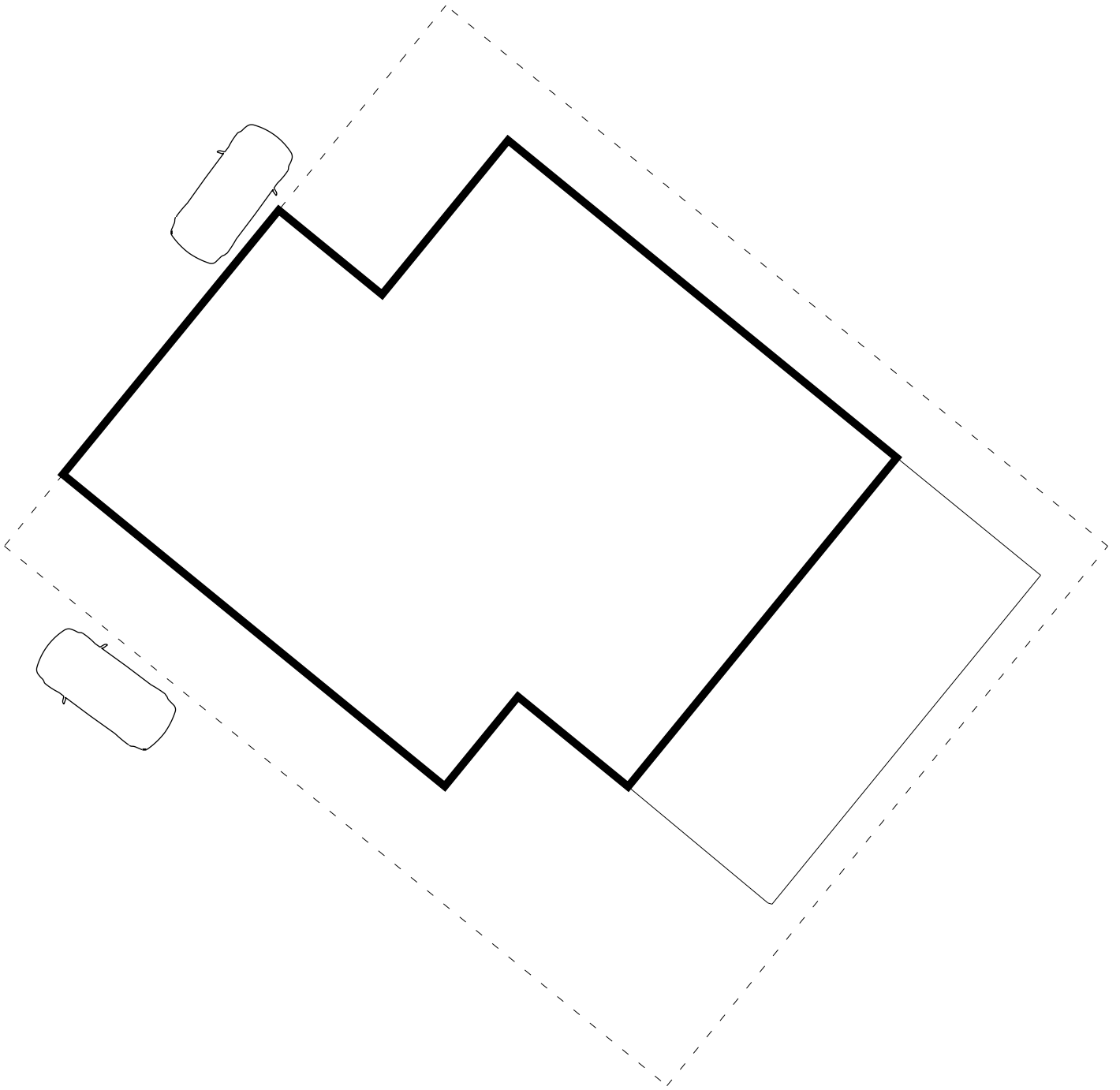

#066 - Casarano - Via Canova, 141

Orientation

Attached Semi Detached

<input type="checkbox"/>	<input type="checkbox"/>	<input checked="" type="checkbox"/>
--------------------------	--------------------------	-------------------------------------

Shape

Box Curvy Geometric

<input checked="" type="checkbox"/>	<input type="checkbox"/>	<input type="checkbox"/>
-------------------------------------	--------------------------	--------------------------

Yard

Front Back None

<input type="checkbox"/>	<input type="checkbox"/>	<input checked="" type="checkbox"/>
--------------------------	--------------------------	-------------------------------------

Borders

Fence Wall None

<input type="checkbox"/>	<input checked="" type="checkbox"/>	<input type="checkbox"/>
--------------------------	-------------------------------------	--------------------------

Parking

Drive Street None

<input type="checkbox"/>	<input checked="" type="checkbox"/>	<input type="checkbox"/>
--------------------------	-------------------------------------	--------------------------

Stairs

Yes No

<input type="checkbox"/>	<input checked="" type="checkbox"/>
--------------------------	-------------------------------------

Site Plan

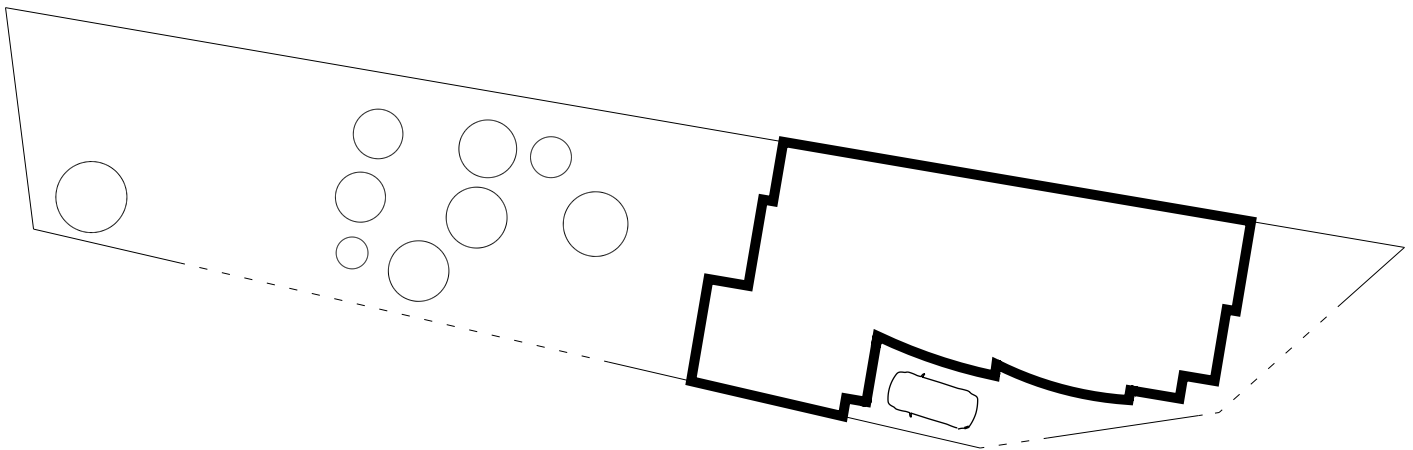

#193 - Minervino di Lecce - Via A.De Gasperi

Orientation

Attached Semi Detached

<input type="checkbox"/>	<input type="checkbox"/>	<input checked="" type="checkbox"/>
--------------------------	--------------------------	-------------------------------------

Shape

Box Curvy Geometric

<input type="checkbox"/>	<input type="checkbox"/>	<input checked="" type="checkbox"/>
--------------------------	--------------------------	-------------------------------------

Yard

Front Back None

<input type="checkbox"/>	<input checked="" type="checkbox"/>	<input type="checkbox"/>
--------------------------	-------------------------------------	--------------------------

Borders

Fence Wall None

<input type="checkbox"/>	<input checked="" type="checkbox"/>	<input type="checkbox"/>
--------------------------	-------------------------------------	--------------------------

Parking

Drive Street None

<input checked="" type="checkbox"/>	<input type="checkbox"/>	<input type="checkbox"/>
-------------------------------------	--------------------------	--------------------------

Stairs

Yes No

<input checked="" type="checkbox"/>	<input type="checkbox"/>
-------------------------------------	--------------------------

Site Plan

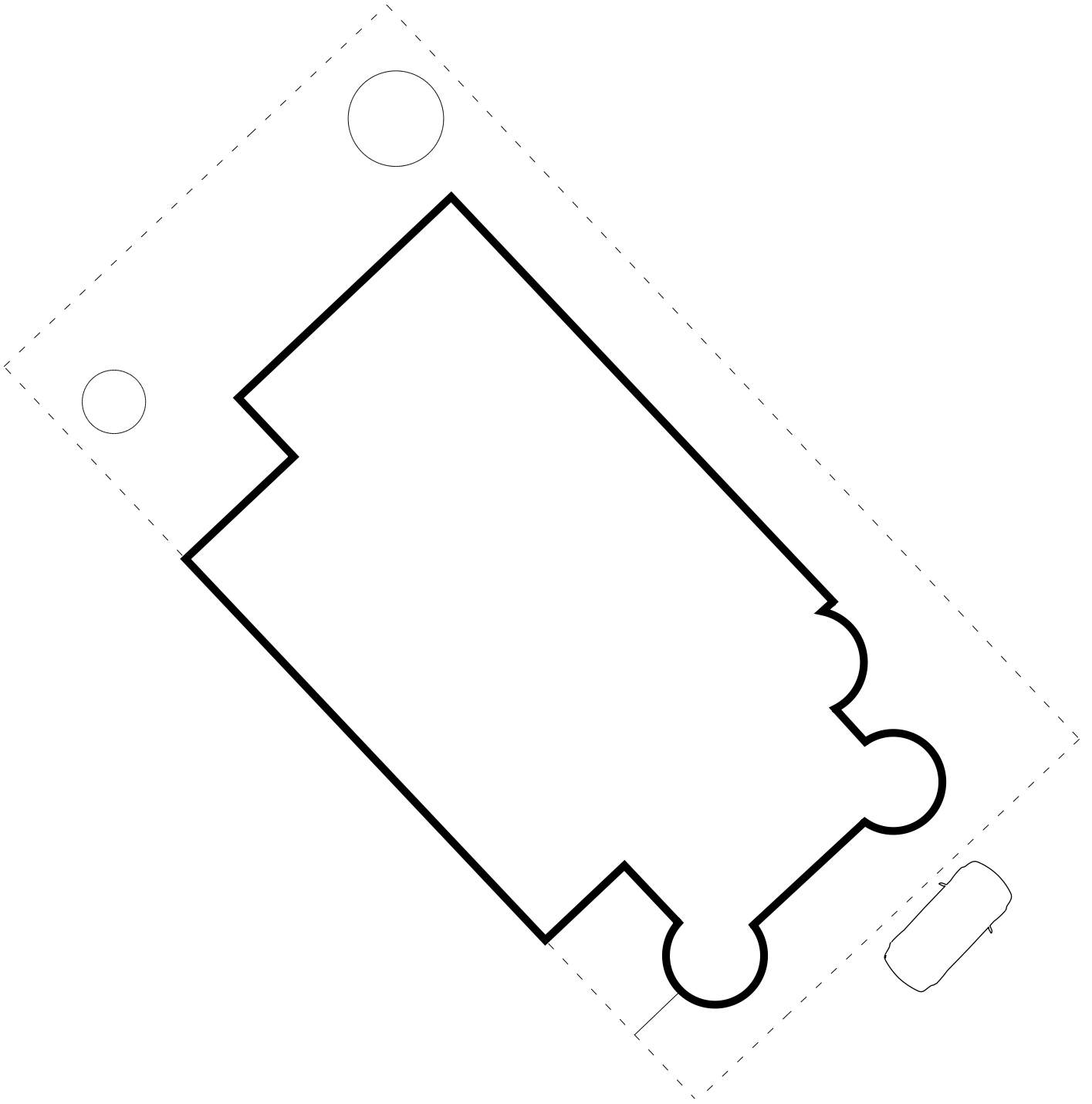

#230 - Moteroni di Lecce - Via Basento, 24

Orientation

Attached Semi Detached



Shape

Box Curvy Geometric



Yard

Front Back None



Borders

Fence Wall None



Parking

Drive Street None



Stairs

Yes No



Site Plan

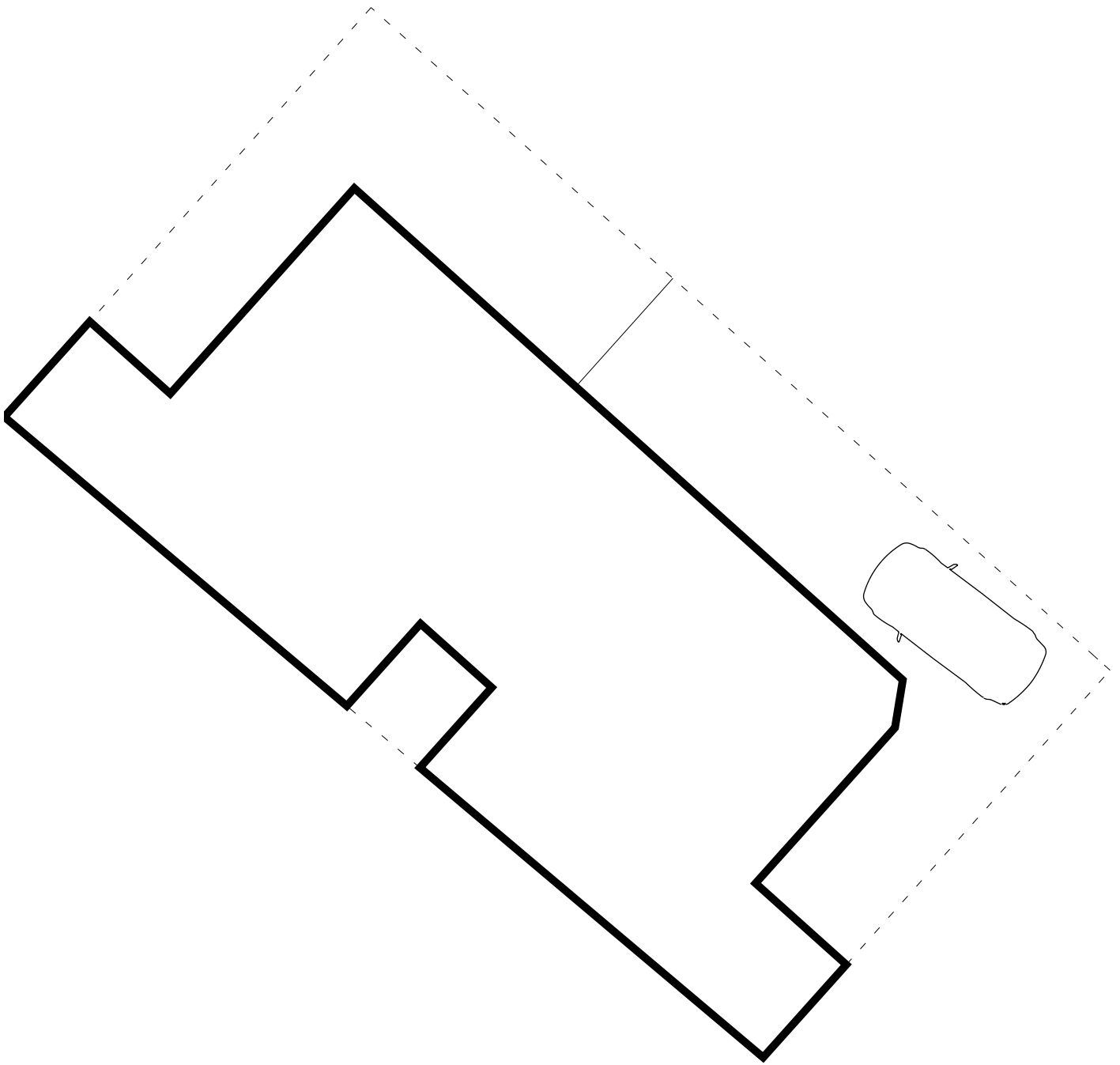

#461 - Tricase - Via Giovanni Gentile, 5

Orientation

Attached Semi Detached



Shape

Box Curvy Geometric



Yard

Front Back None



Borders

Fence Wall None



Parking

Drive Street None



Stairs

Yes No



Site Plan

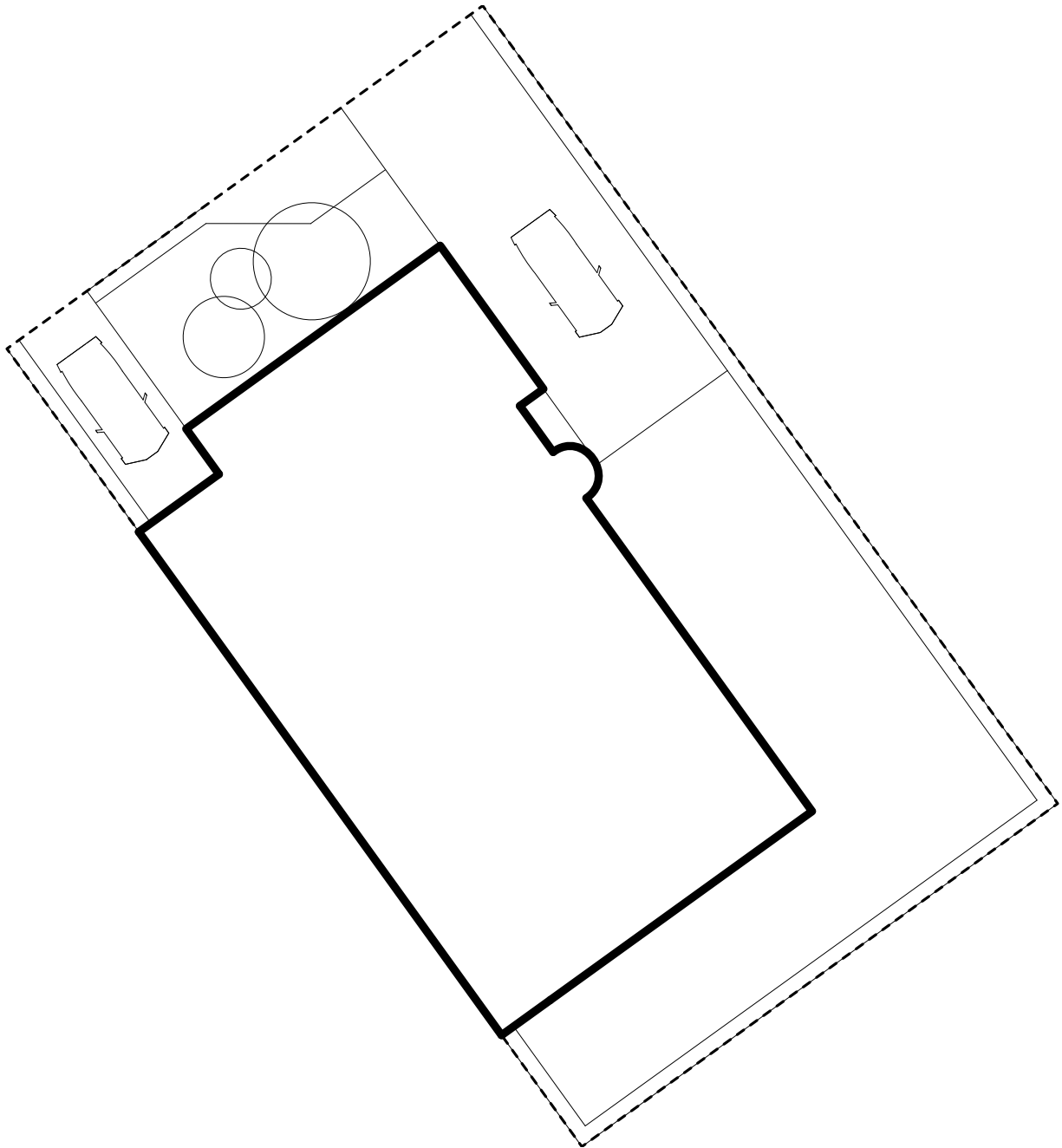

#476 - Ugento - Via S. Antonio, 58

Orientation

Attached Semi Detached



Shape

Box Curvy Geometric



Yard

Front Back None



Borders

Fence Wall None



Parking

Drive Street None



Stairs

Yes No



Site Plan

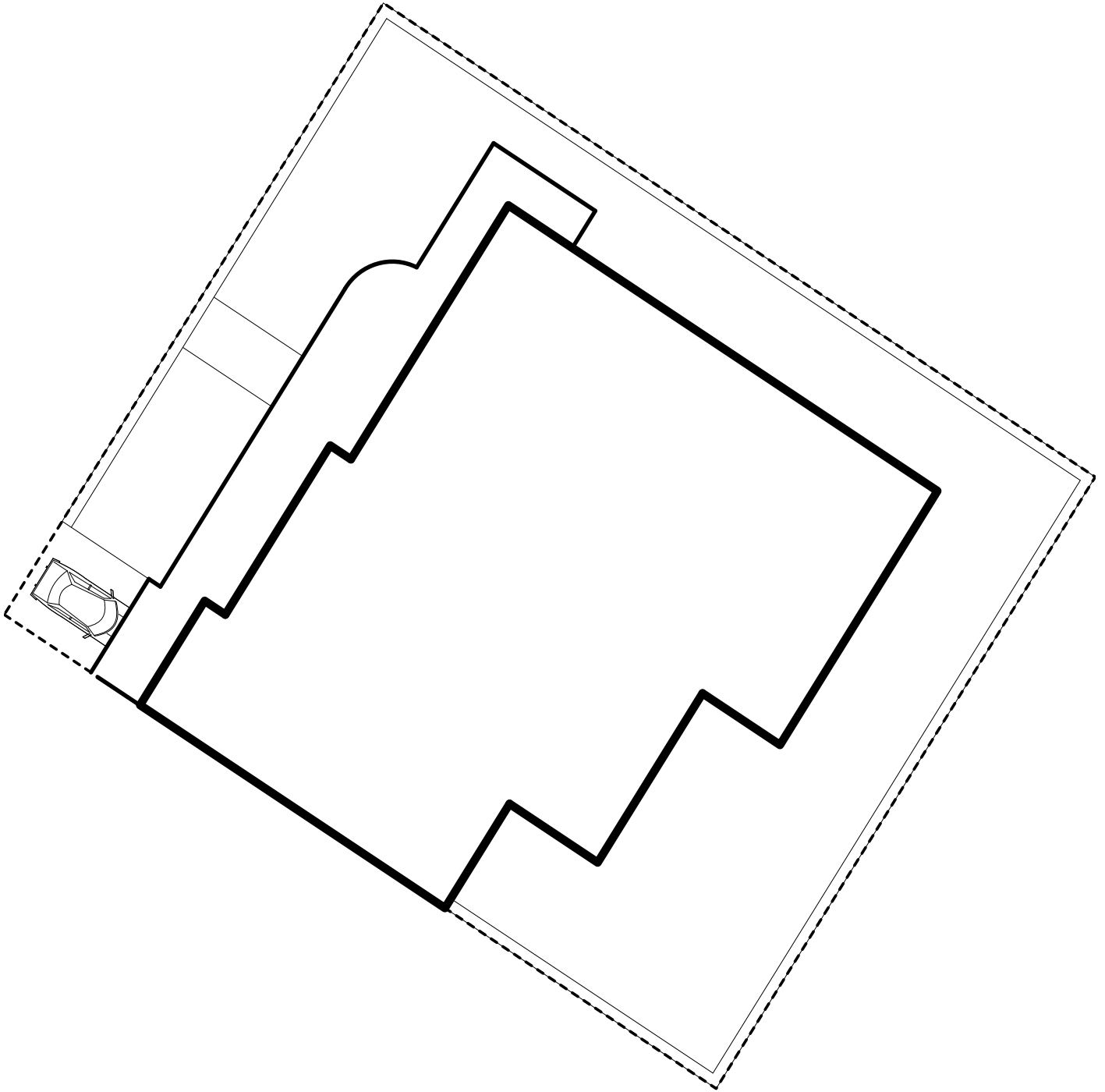

#487 - Ugento - Via S. Biagio, 25

Orientation

Attached Semi Detached



Shape

Box Curvy Geometric



Yard

Front Back None



Borders

Fence Wall None



Parking

Drive Street None



Stairs

Yes No



Site Plan

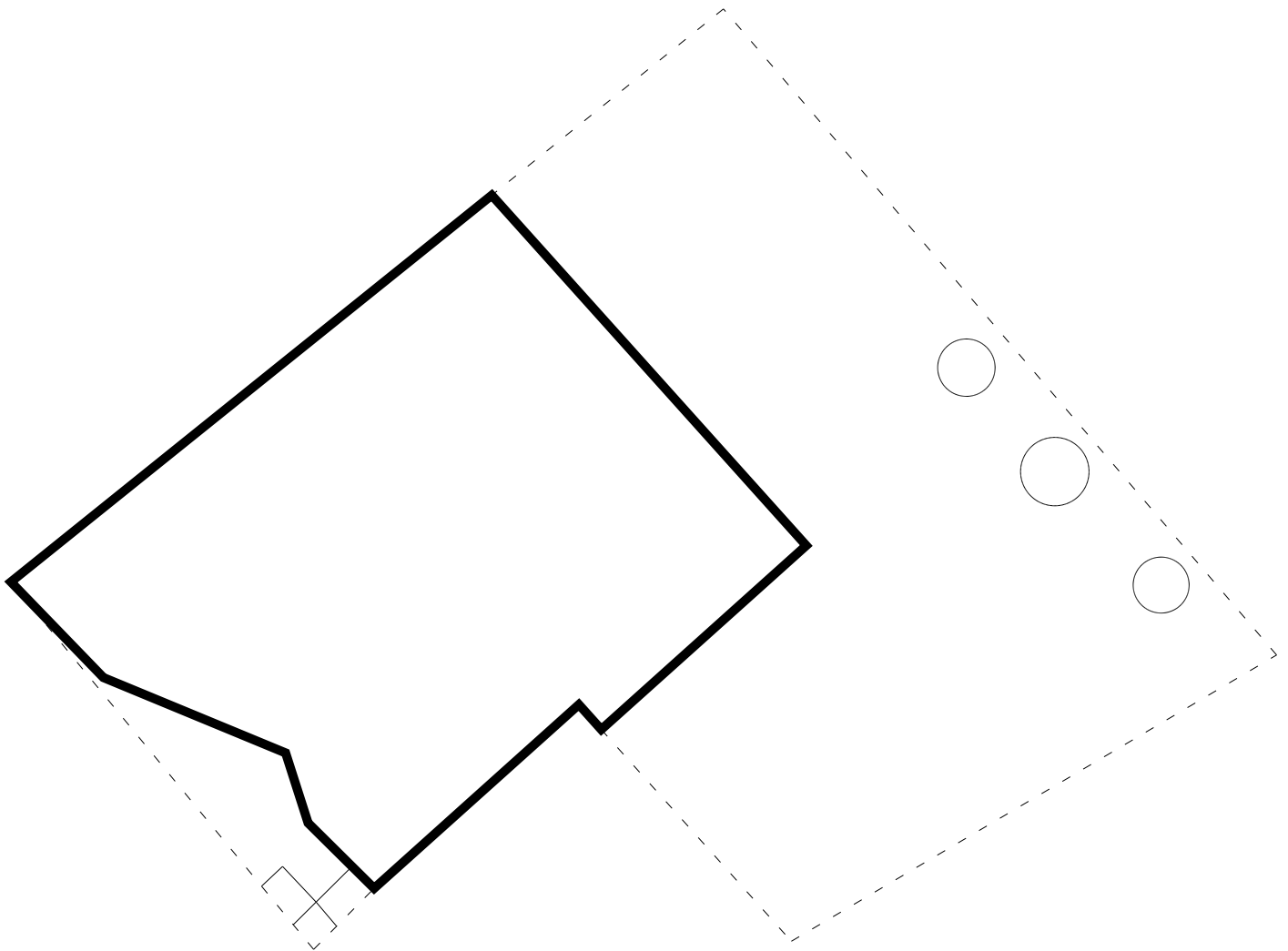

#484 - Ugento - Via Liguria, 11

Orientation

Attached Semi Detached



Shape

Box Curvy Geometric



Yard

Front Back None



Borders

Fence Wall None



Parking

Drive Street None



Stairs

Yes No



Site Plan

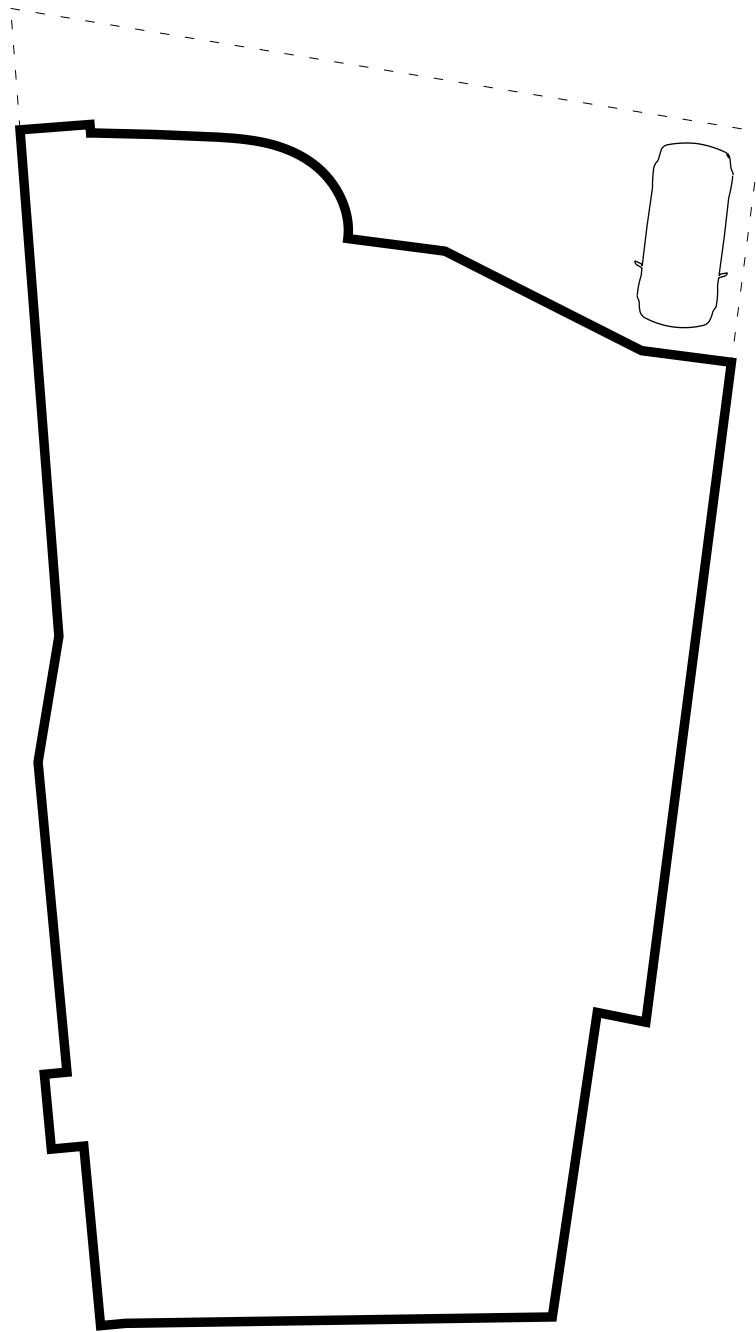

#499 - Vernole - Via Nino Bixio, 5

Orientation

Attached Semi Detached

<input checked="" type="checkbox"/>	<input type="checkbox"/>	<input type="checkbox"/>
-------------------------------------	--------------------------	--------------------------

Shape

Box Curvy Geometric

<input type="checkbox"/>	<input checked="" type="checkbox"/>	<input type="checkbox"/>
--------------------------	-------------------------------------	--------------------------

Yard

Front Back None

<input checked="" type="checkbox"/>	<input type="checkbox"/>	<input type="checkbox"/>
-------------------------------------	--------------------------	--------------------------

Borders

Fence Wall None

<input checked="" type="checkbox"/>	<input type="checkbox"/>	<input type="checkbox"/>
-------------------------------------	--------------------------	--------------------------

Parking

Drive Street None

<input checked="" type="checkbox"/>	<input type="checkbox"/>	<input type="checkbox"/>
-------------------------------------	--------------------------	--------------------------

Stairs

Yes No

<input type="checkbox"/>	<input checked="" type="checkbox"/>
--------------------------	-------------------------------------

Site Plan

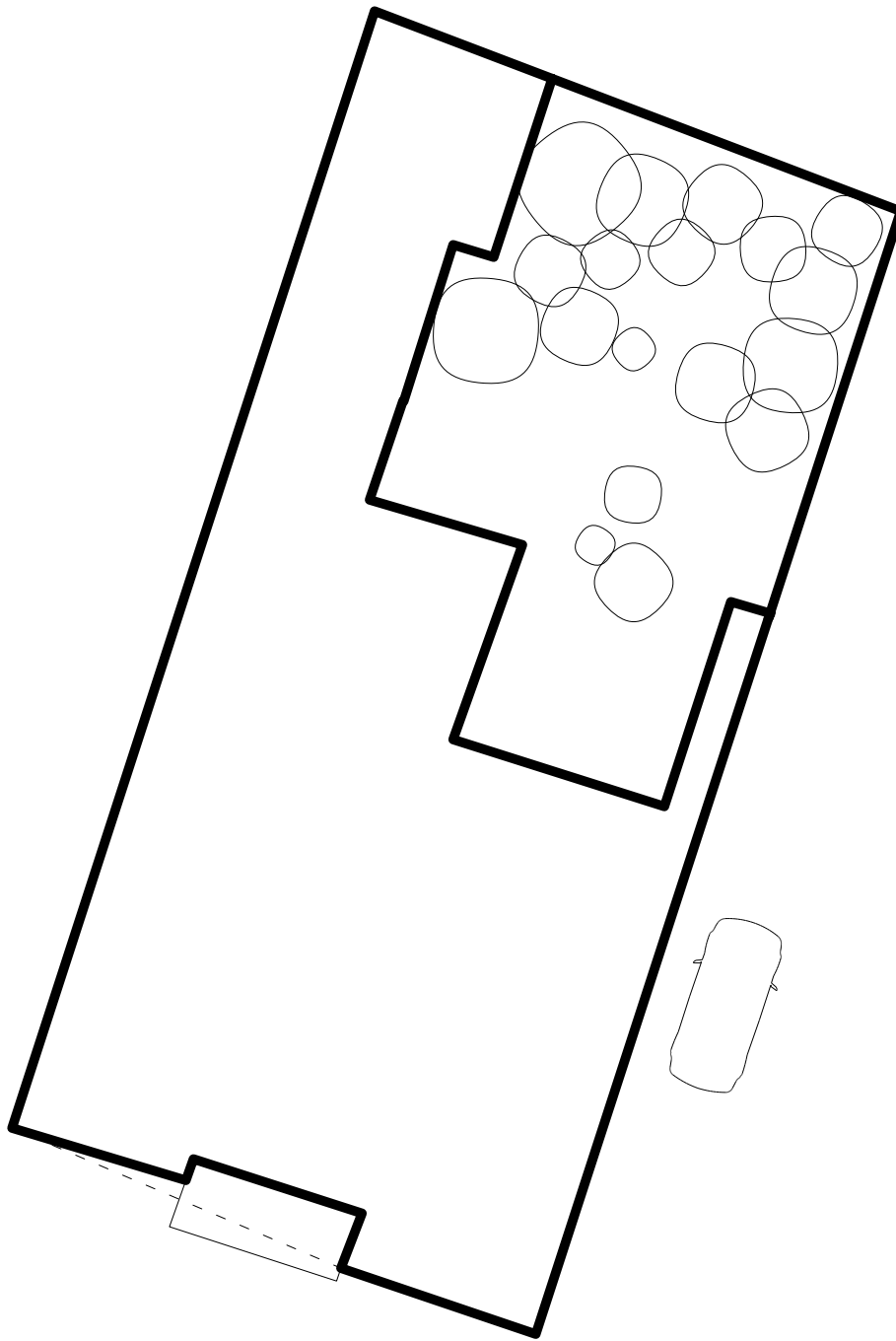

#005 - Acaya - SP142

Orientation

Attached Semi Detached



Shape

Box Curvy Geometric



Yard

Front Back None



Borders

Fence Wall None



Parking

Drive Street None



Stairs

Yes No



Site Plan

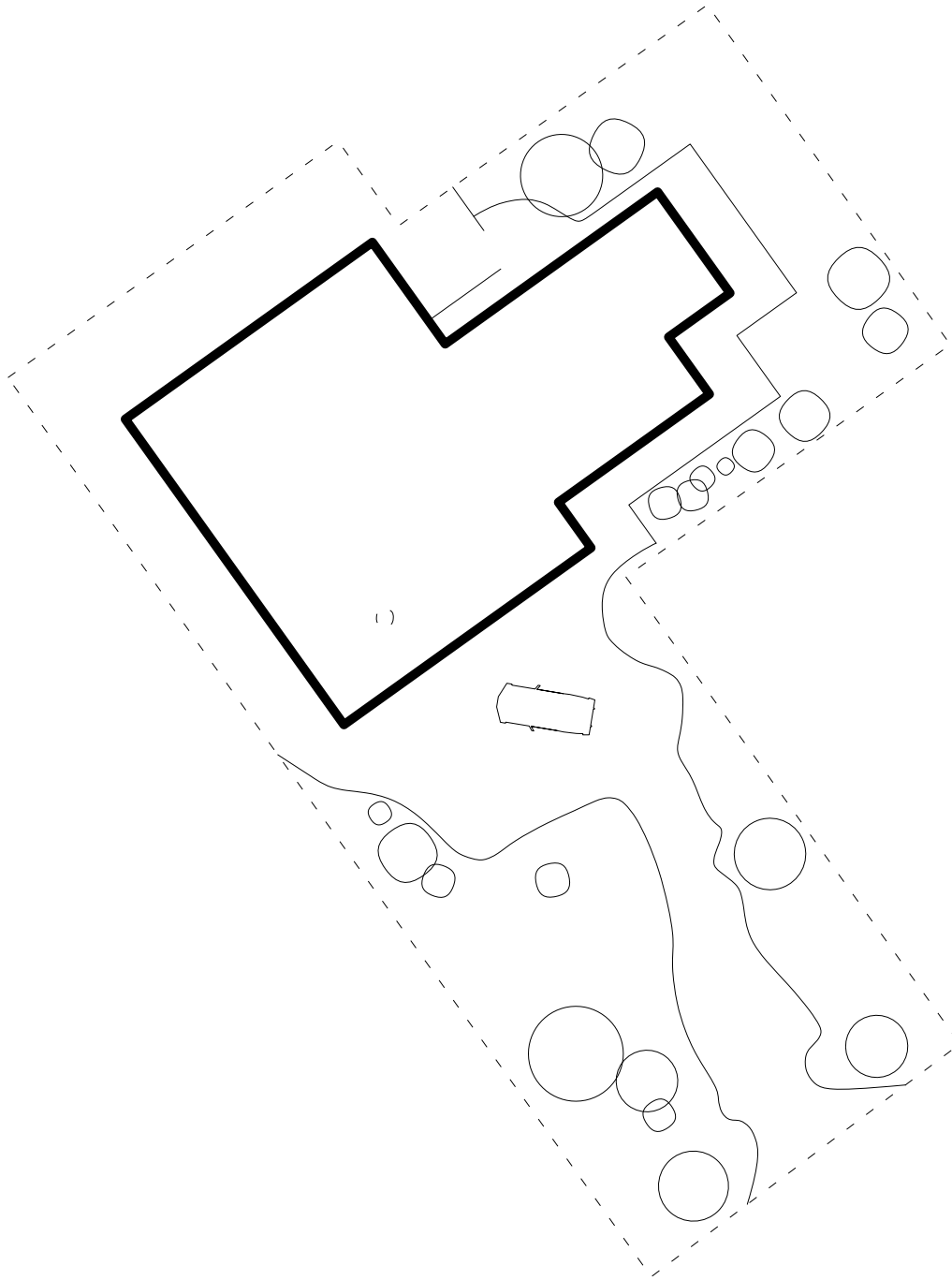

#033 - Alessano - Via G. Di vittoria

Orientation

Attached Semi Detached



Shape

Box Curvy Geometric



Yard

Front Back None



Borders

Fence Wall None



Parking

Drive Street None



Stairs

Yes No



Site Plan

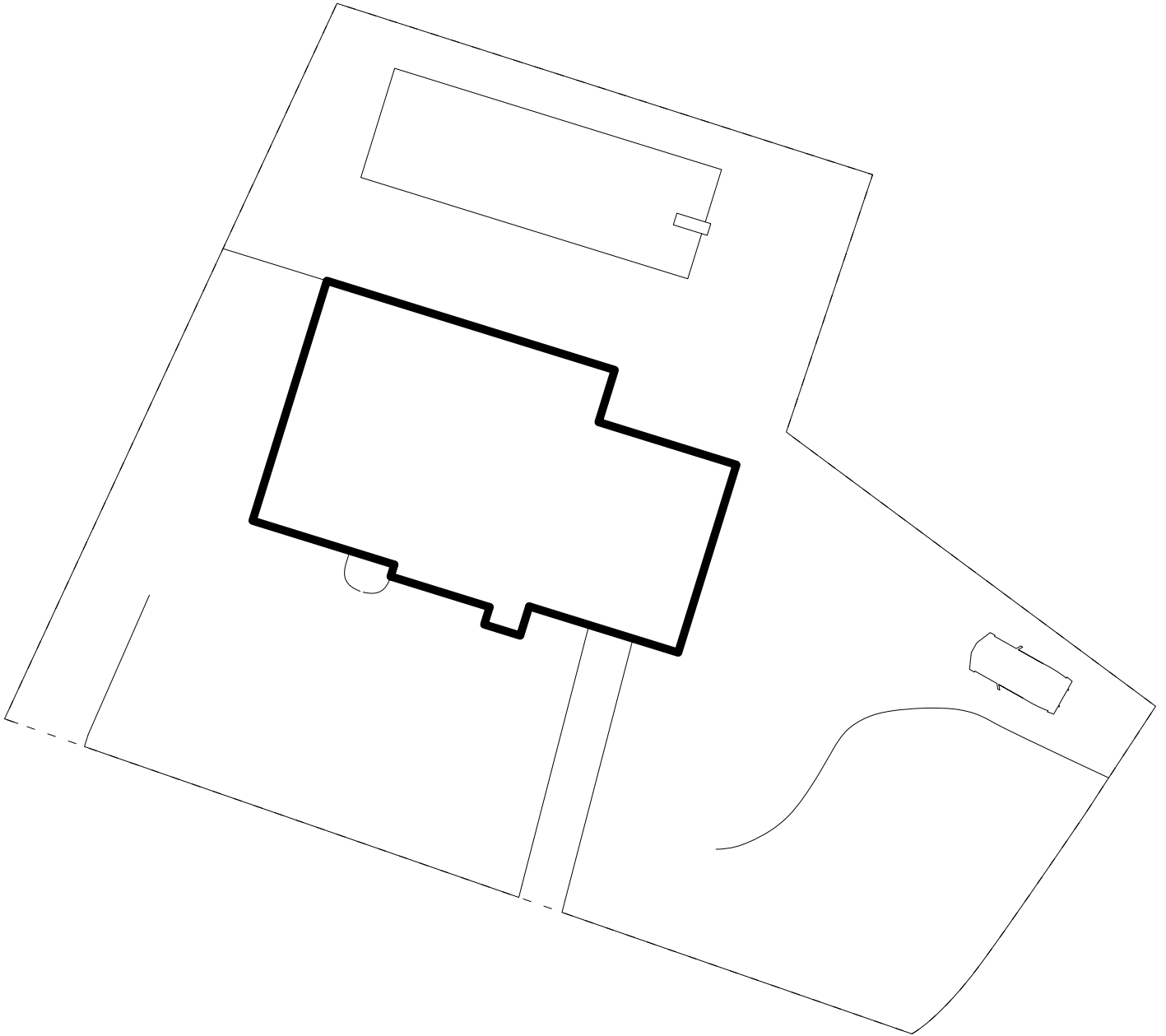

#028 - Alessano - 70 Via Fosso Muraglie

Orientation

Attached Semi Detached

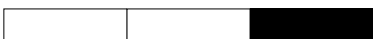

Shape

Box Curvy Geometric



Yard

Front Back None



Borders

Fence Wall None



Parking

Drive Street None



Stairs

Yes No



Site Plan

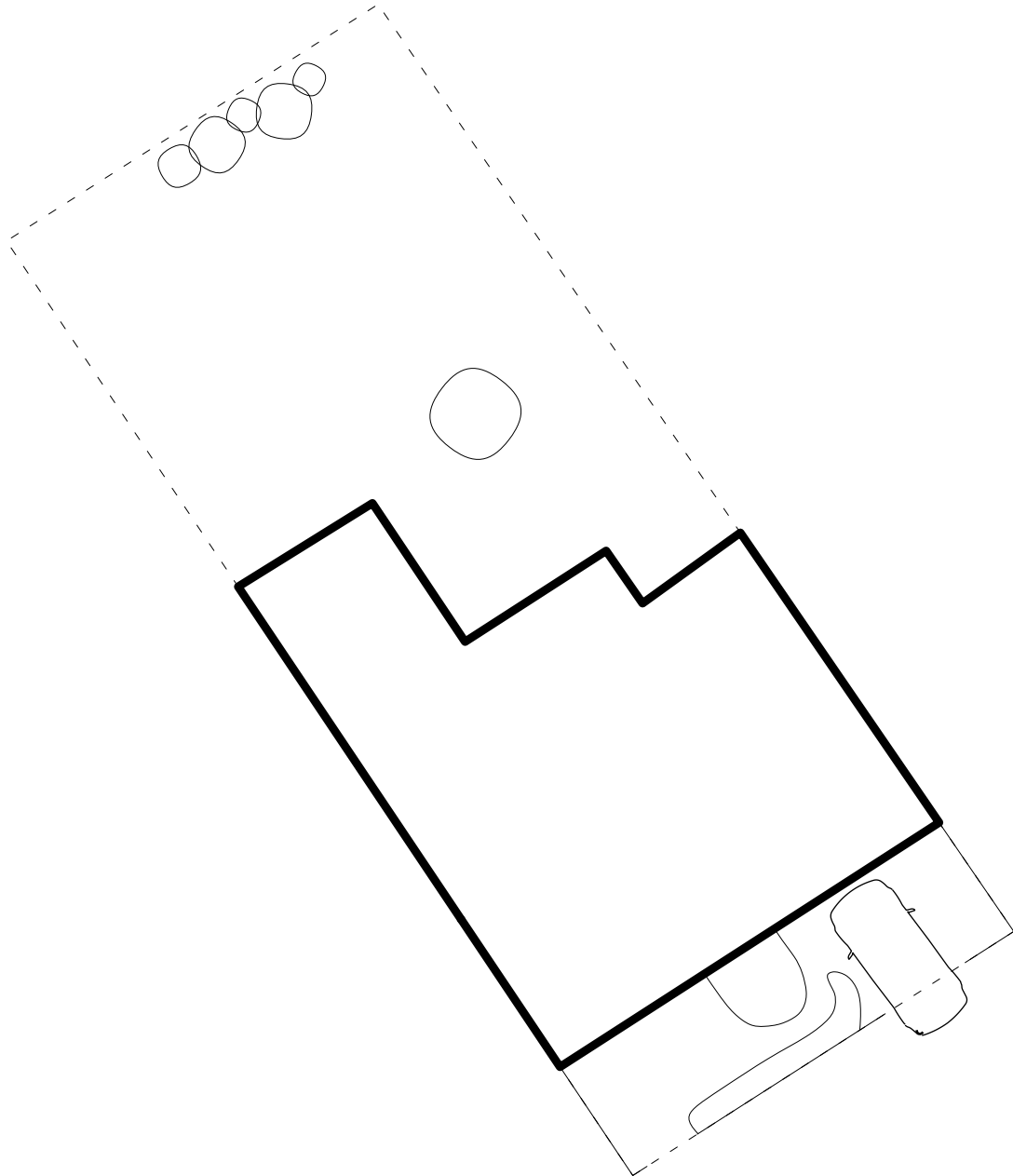

#007 - Acaya - 13 Via Liguria

Orientation

Attached Semi Detached



Shape

Box Curvy Geometric



Yard

Front Back None



Borders

Fence Wall None



Parking

Drive Street None



Stairs

Yes No



Site Plan

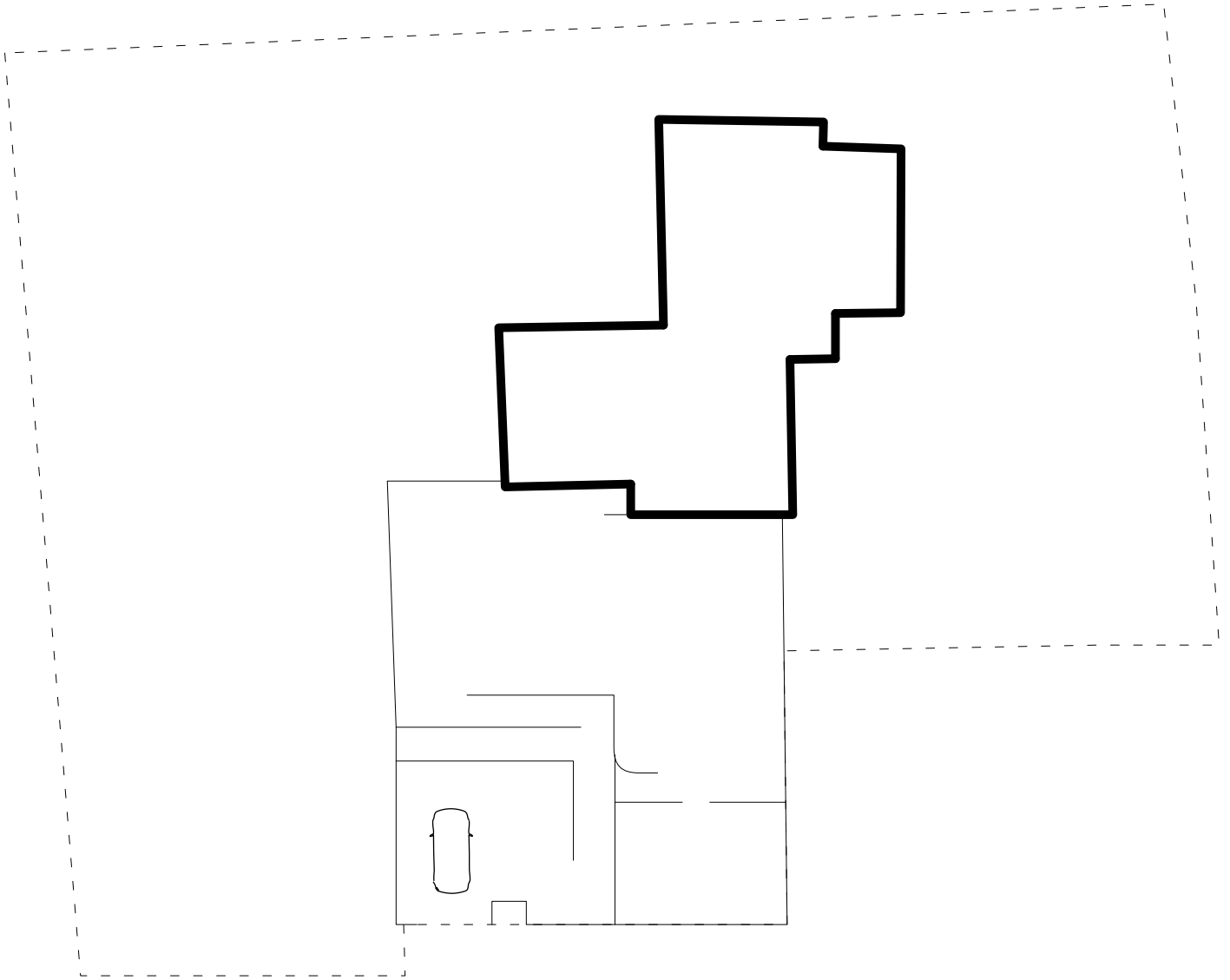

#026 - Alessano - 24 Via Lapineta

Orientation

Attached Semi Detached



Shape

Box Curvy Geometric



Yard

Front Back None



Borders

Fence Wall None



Parking

Drive Street None



Stairs

Yes No



Site Plan

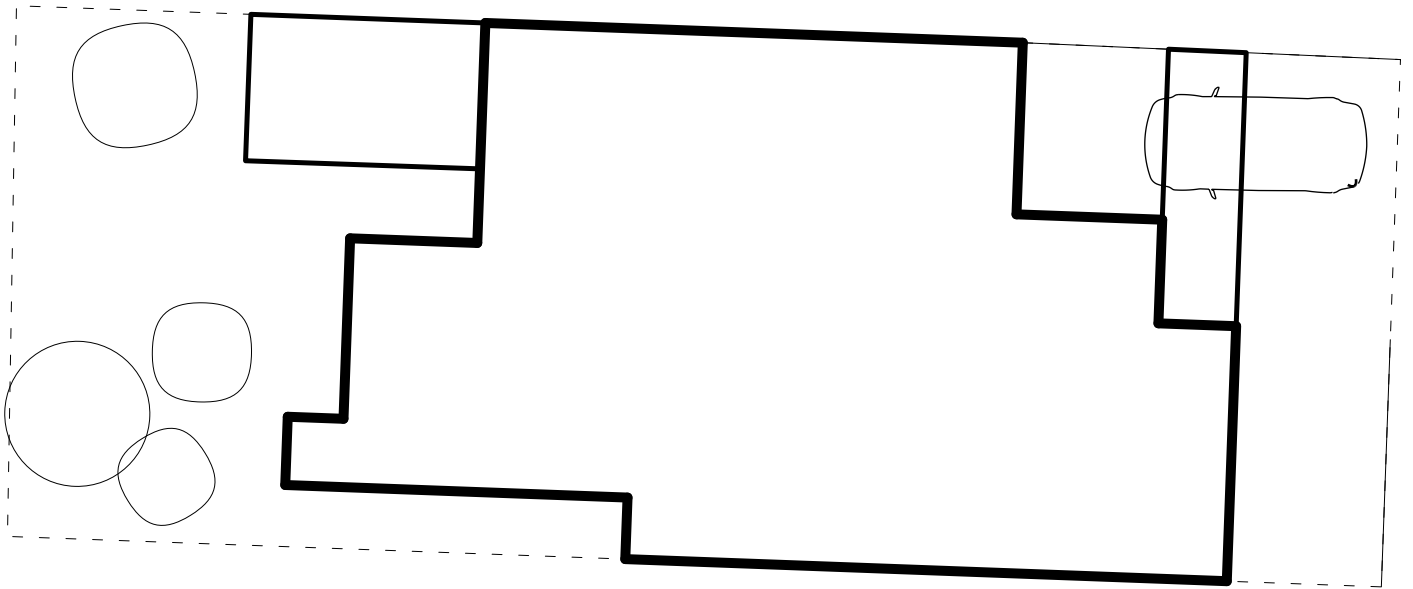

#047 - Alezio - Via Giosuè Carducci, 7

Orientation

Attached Semi Detached

<input checked="" type="checkbox"/>	<input type="checkbox"/>	<input type="checkbox"/>
-------------------------------------	--------------------------	--------------------------

Shape

Box Curvy Geometric

<input checked="" type="checkbox"/>	<input type="checkbox"/>	<input type="checkbox"/>
-------------------------------------	--------------------------	--------------------------

Yard

Front Back None

<input type="checkbox"/>	<input checked="" type="checkbox"/>	<input type="checkbox"/>
--------------------------	-------------------------------------	--------------------------

Borders

Fence Wall None

<input type="checkbox"/>	<input checked="" type="checkbox"/>	<input type="checkbox"/>
--------------------------	-------------------------------------	--------------------------

Parking

Drive Street None

<input checked="" type="checkbox"/>	<input type="checkbox"/>	<input type="checkbox"/>
-------------------------------------	--------------------------	--------------------------

Stairs

Yes No

<input type="checkbox"/>	<input checked="" type="checkbox"/>
--------------------------	-------------------------------------

Site Plan

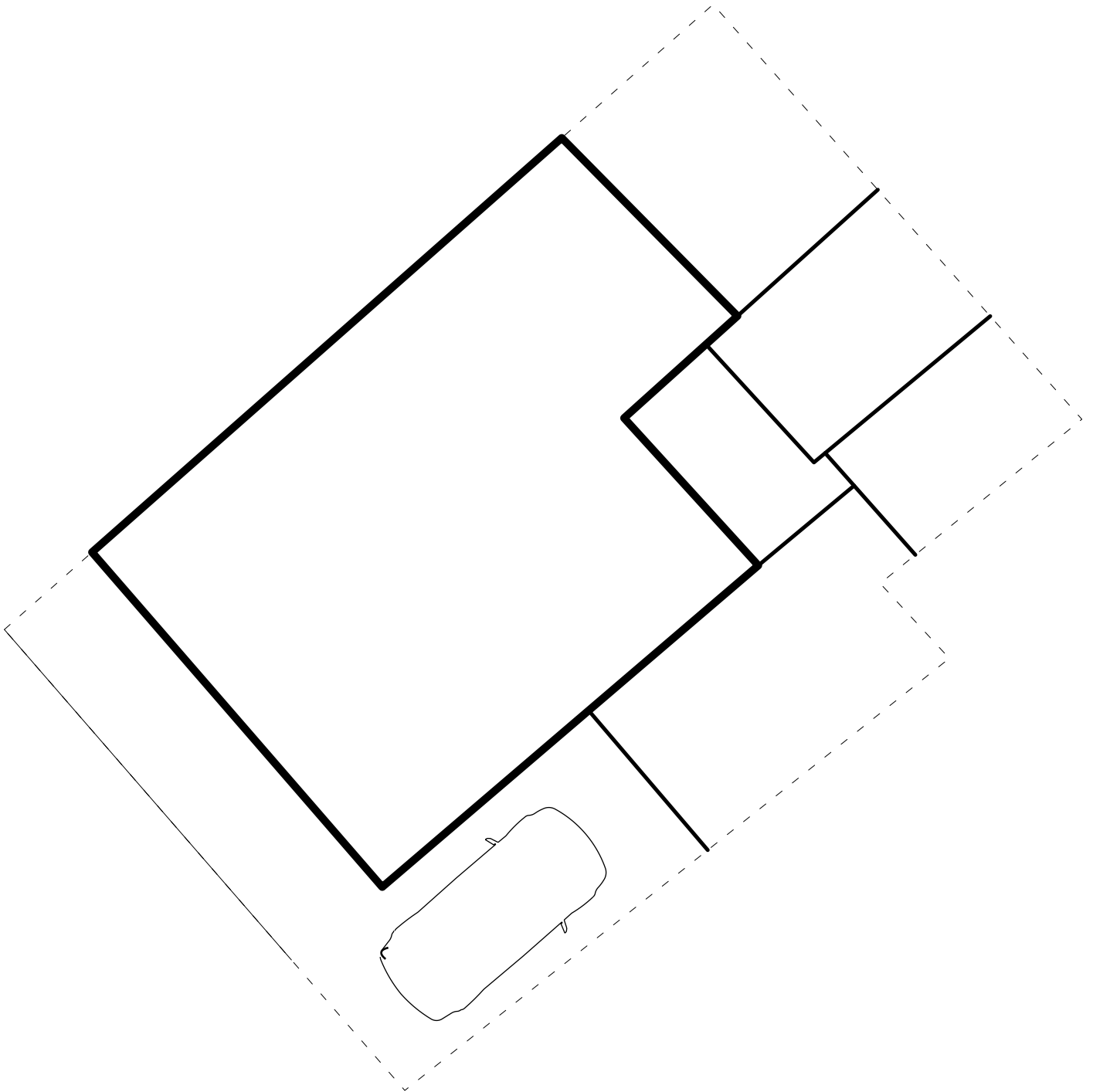

#071 - Casarano - Via Massimo d'Azeglio, 146

Orientation

Attached Semi Detached



Shape

Box Curvy Geometric



Yard

Front Back None



Borders

Fence Wall None



Parking

Drive Street None



Stairs

Yes No



Site Plan

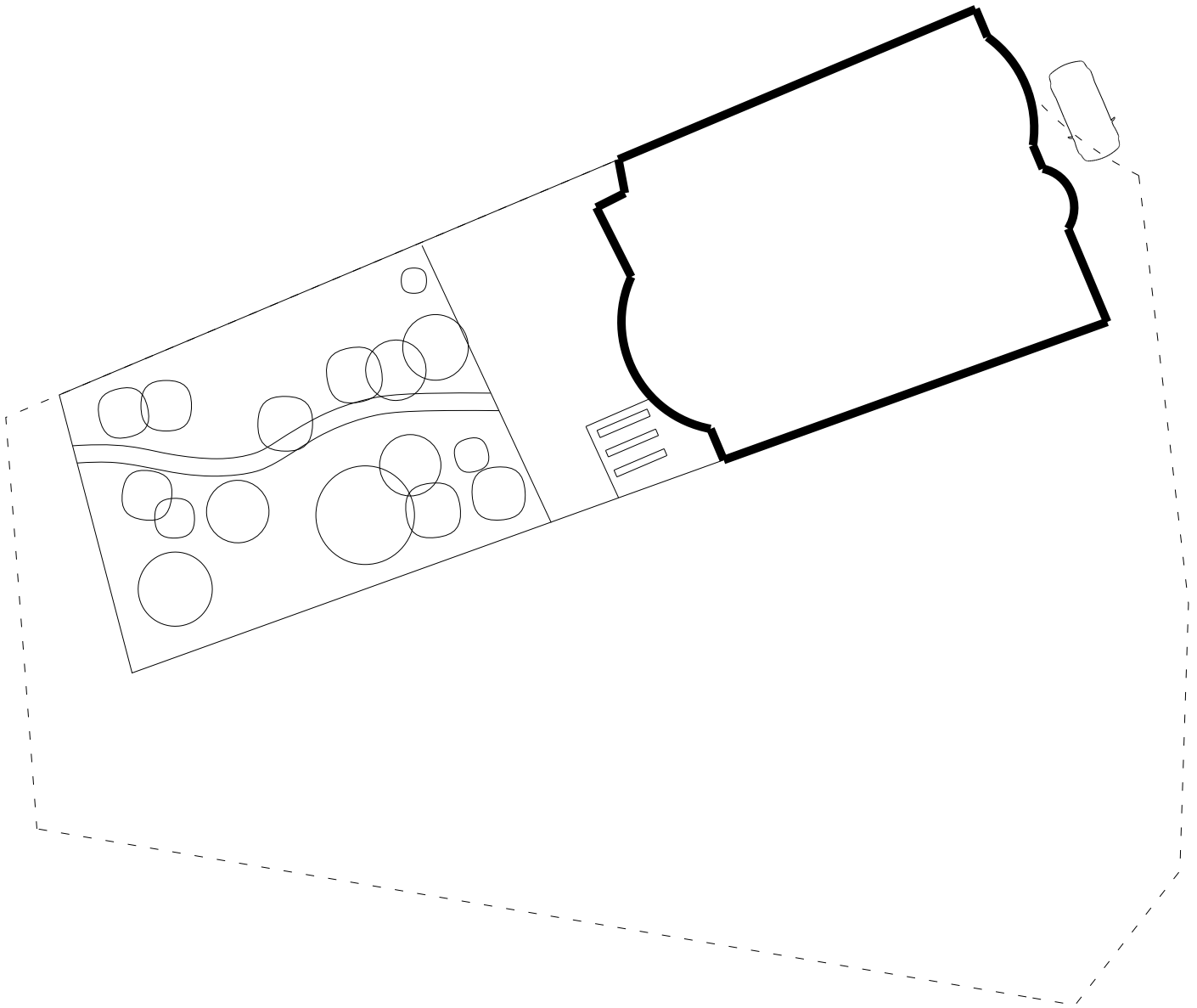

#494 - Vernole - 40 Via Giovanni XXIII

Orientation

Attached Semi Detached



Shape

Box Curvy Geometric



Yard

Front Back None



Borders

Fence Wall None



Parking

Drive Street None



Stairs

Yes No



Site Plan

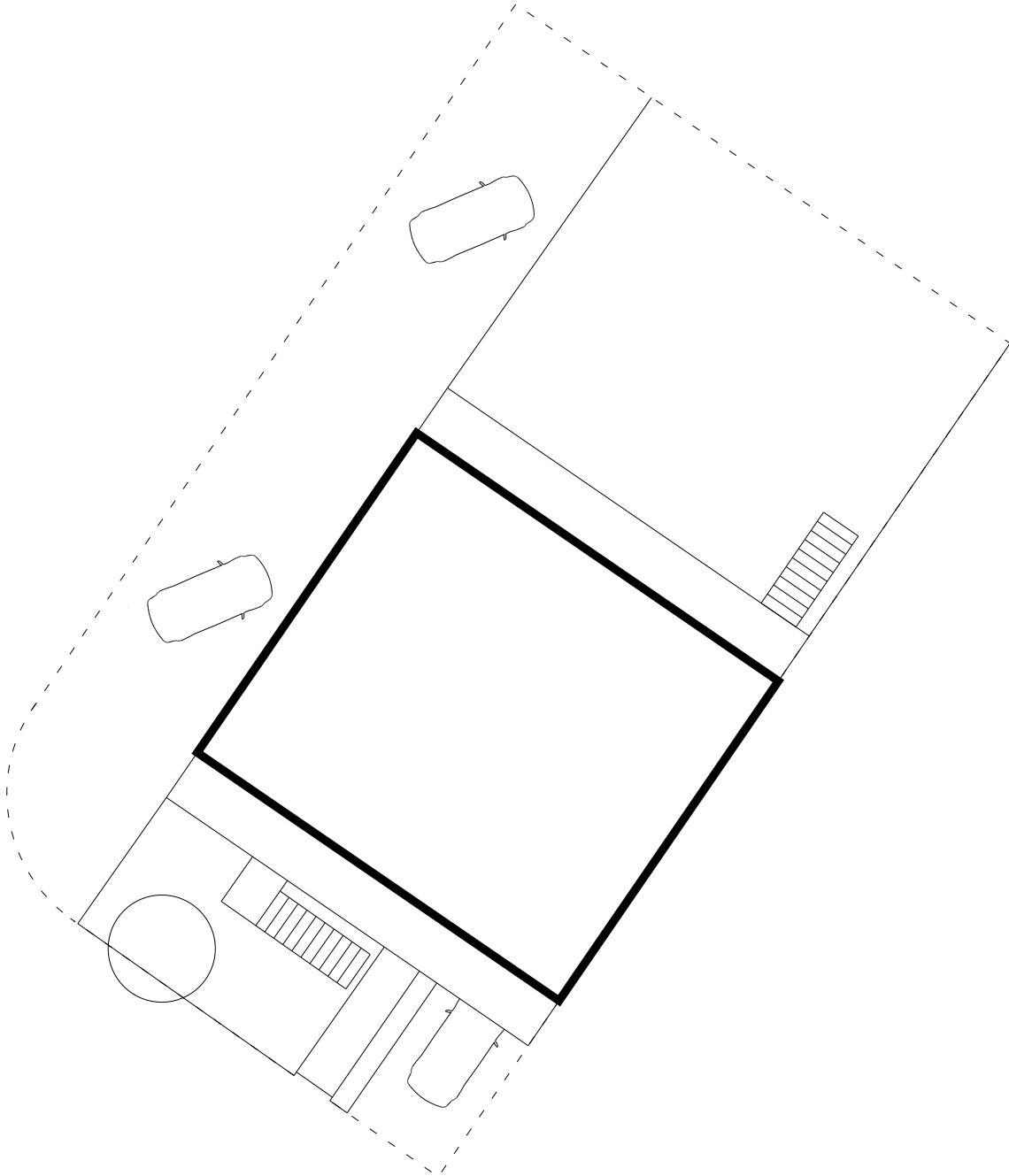

#483 - Ugento - Via Mura Messapiche

Orientation

Attached Semi Detached



Shape

Box Curvy Geometric



Yard

Front Back None



Borders

Fence Wall None



Parking

Drive Street None



Stairs

Yes No



Site Plan

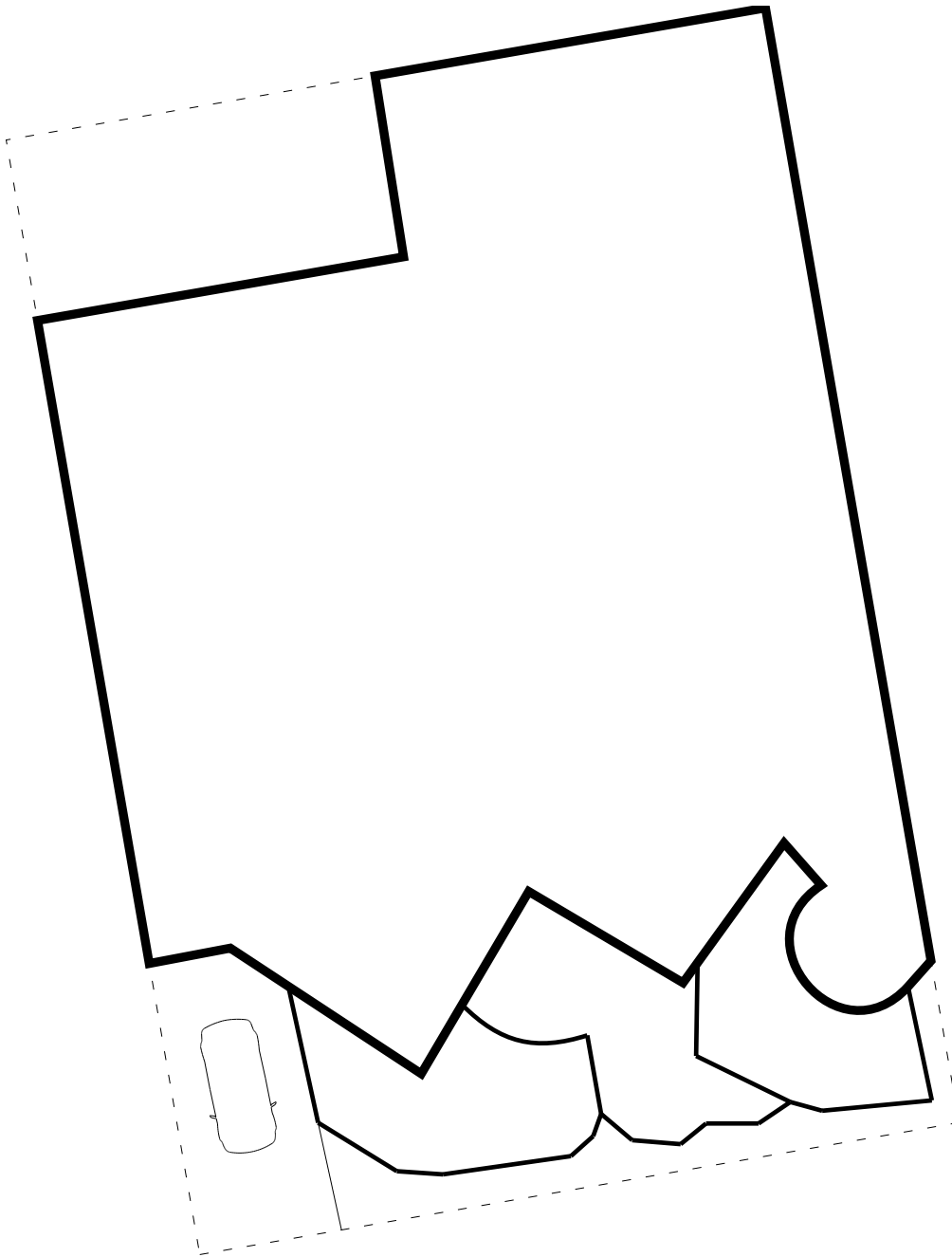

#492 - Vernole - 10 Via Giovanni XXIII

Orientation

Attached Semi Detached



Shape

Box Curvy Geometric



Yard

Front Back None



Borders

Fence Wall None



Parking

Drive Street None



Stairs

Yes No



Site Plan

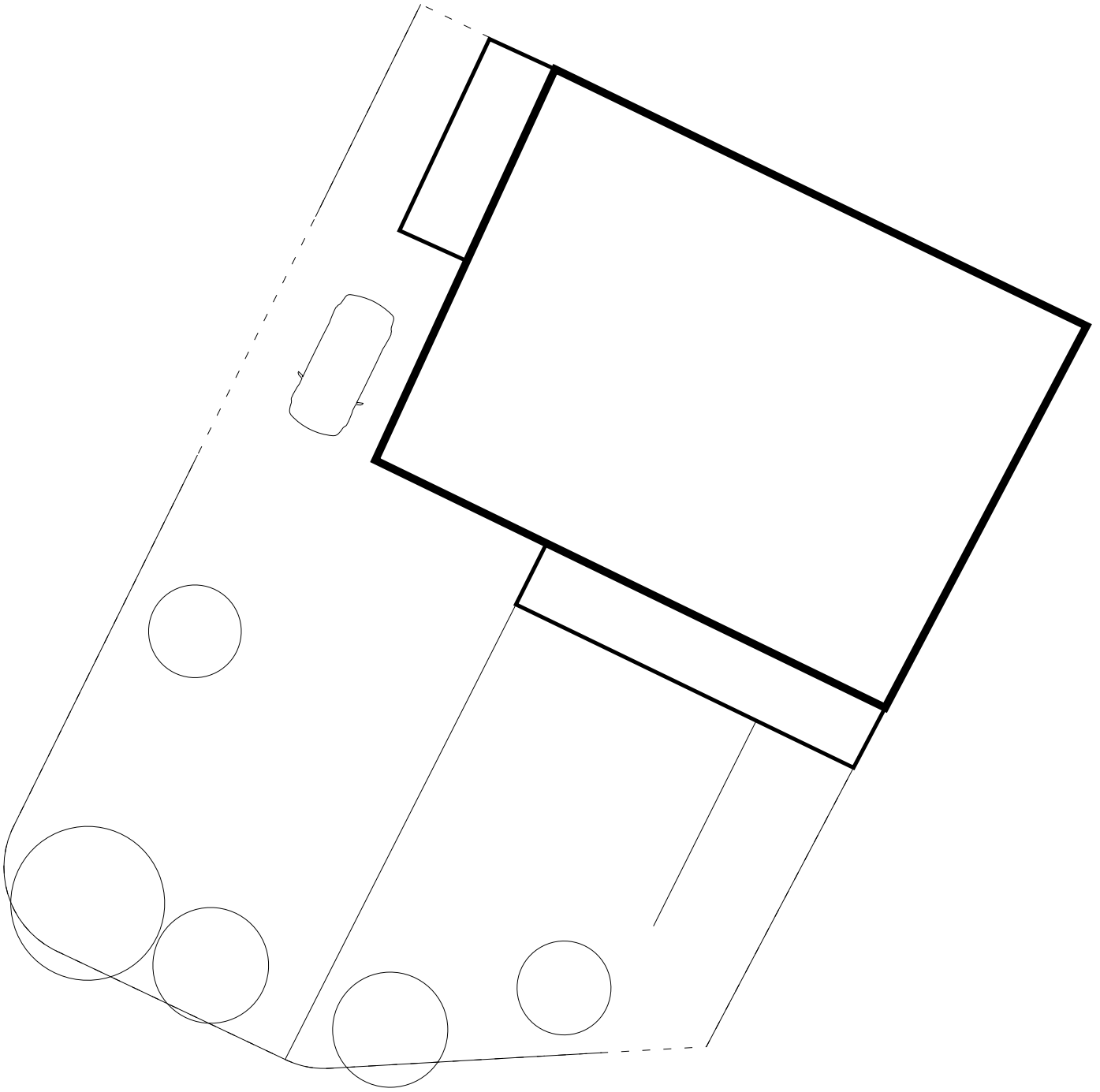

#145 - Maglie - Via F. Casatello, 28-32

Orientation

Attached Semi Detached



Shape

Box Curvy Geometric



Yard

Front Back None

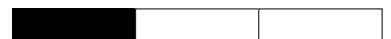

Borders

Fence Wall None



Parking

Drive Street None



Stairs

Yes No



Site Plan

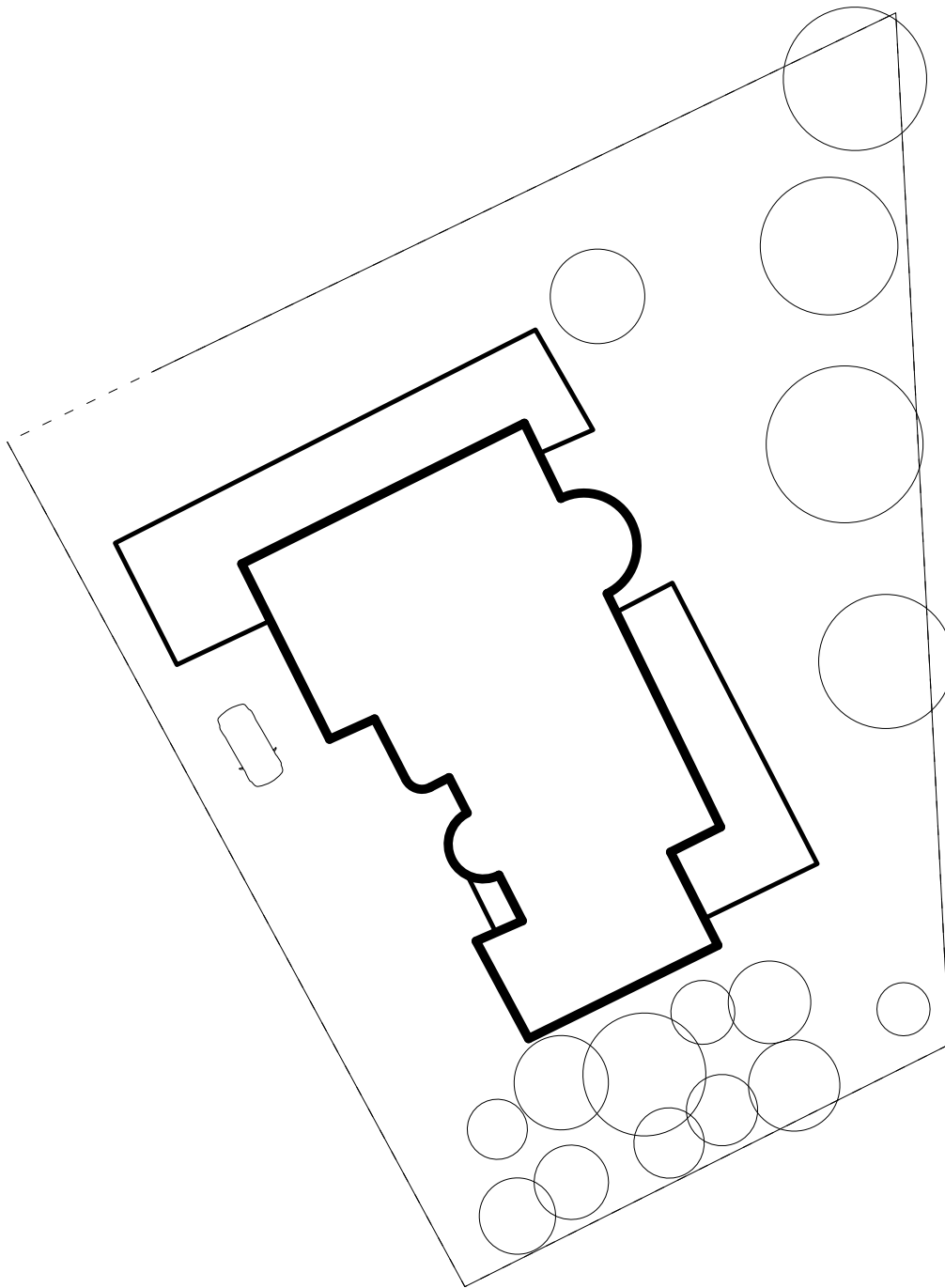

#152 - Maglie - Via Luigi Einaudi, 1

Orientation

Attached Semi Detached

<input type="checkbox"/>	<input type="checkbox"/>	<input checked="" type="checkbox"/>
--------------------------	--------------------------	-------------------------------------

Shape

Box Curvy Geometric

<input type="checkbox"/>	<input checked="" type="checkbox"/>	<input type="checkbox"/>
--------------------------	-------------------------------------	--------------------------

Yard

Front Back None

<input checked="" type="checkbox"/>	<input type="checkbox"/>	<input type="checkbox"/>
-------------------------------------	--------------------------	--------------------------

Borders

Fence Wall None

<input checked="" type="checkbox"/>	<input type="checkbox"/>	<input type="checkbox"/>
-------------------------------------	--------------------------	--------------------------

Parking

Drive Street None

<input checked="" type="checkbox"/>	<input type="checkbox"/>	<input type="checkbox"/>
-------------------------------------	--------------------------	--------------------------

Stairs

Yes No

<input type="checkbox"/>	<input checked="" type="checkbox"/>
--------------------------	-------------------------------------

Site Plan

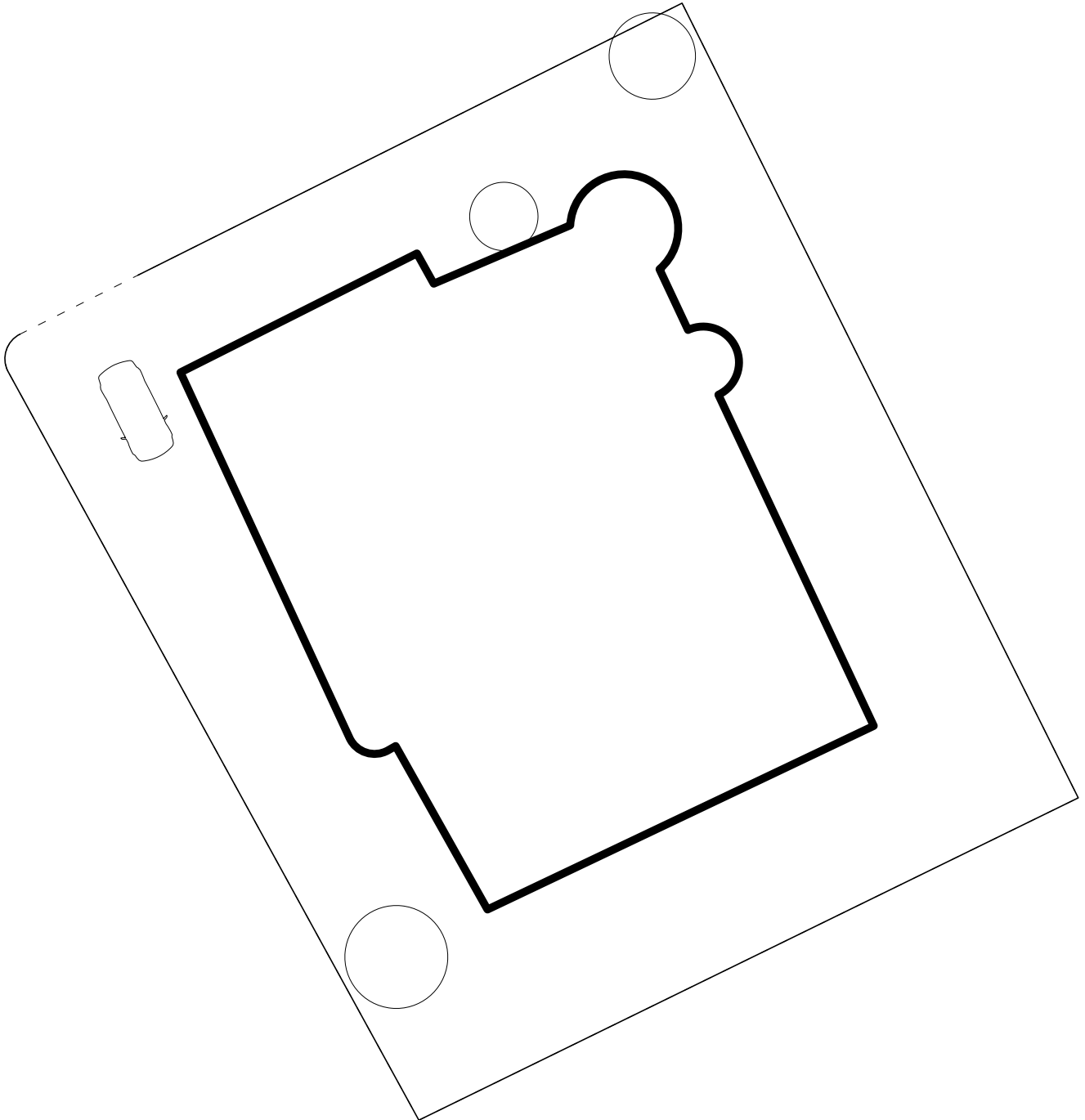

#154 - Maglie - Via Luigi Einaudi, 15-13

Orientation

Attached Semi Detached



Shape

Box Curvy Geometric



Yard

Front Back None



Borders

Fence Wall None



Parking

Drive Street None



Stairs

Yes No



Site Plan

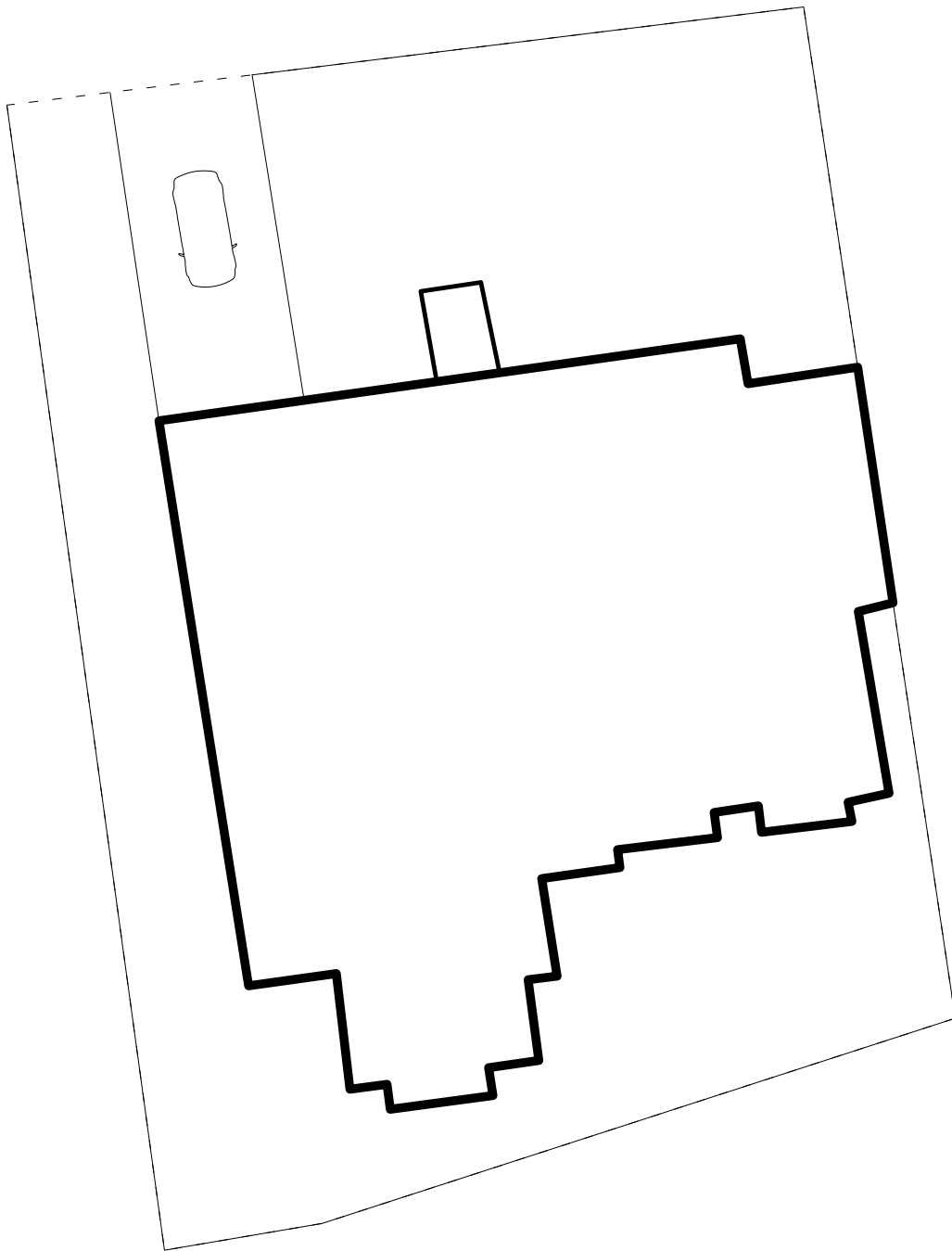

#189 - Minervino di Lecce - Via Don Sturzo, 38

Orientation

Attached Semi Detached

<input type="checkbox"/>	<input type="checkbox"/>	<input checked="" type="checkbox"/>
--------------------------	--------------------------	-------------------------------------

Shape

Box Curvy Geometric

<input type="checkbox"/>	<input type="checkbox"/>	<input checked="" type="checkbox"/>
--------------------------	--------------------------	-------------------------------------

Yard

Front Back None

<input checked="" type="checkbox"/>	<input type="checkbox"/>	<input type="checkbox"/>
-------------------------------------	--------------------------	--------------------------

Borders

Fence Wall None

<input checked="" type="checkbox"/>	<input type="checkbox"/>	<input type="checkbox"/>
-------------------------------------	--------------------------	--------------------------

Parking

Drive Street None

<input checked="" type="checkbox"/>	<input type="checkbox"/>	<input type="checkbox"/>
-------------------------------------	--------------------------	--------------------------

Stairs

Yes No

<input checked="" type="checkbox"/>	<input type="checkbox"/>
-------------------------------------	--------------------------

Site Plan

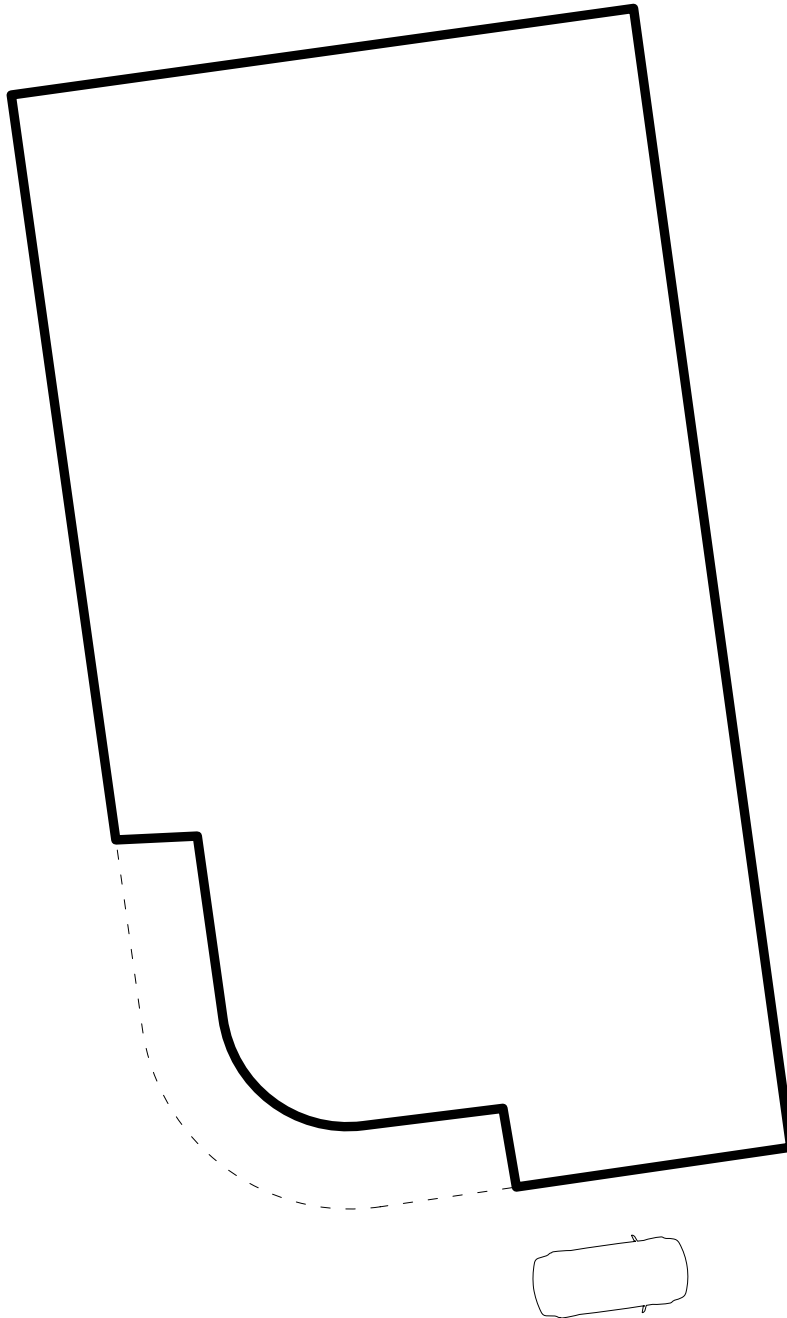

#190 - Minervino di Lecce - 45 Via Don Sturzo

Orientation

Attached Semi Detached



Shape

Box Curvy Geometric



Yard

Front Back None



Borders

Fence Wall None



Parking

Drive Street None



Stairs

Yes No



Site Plan

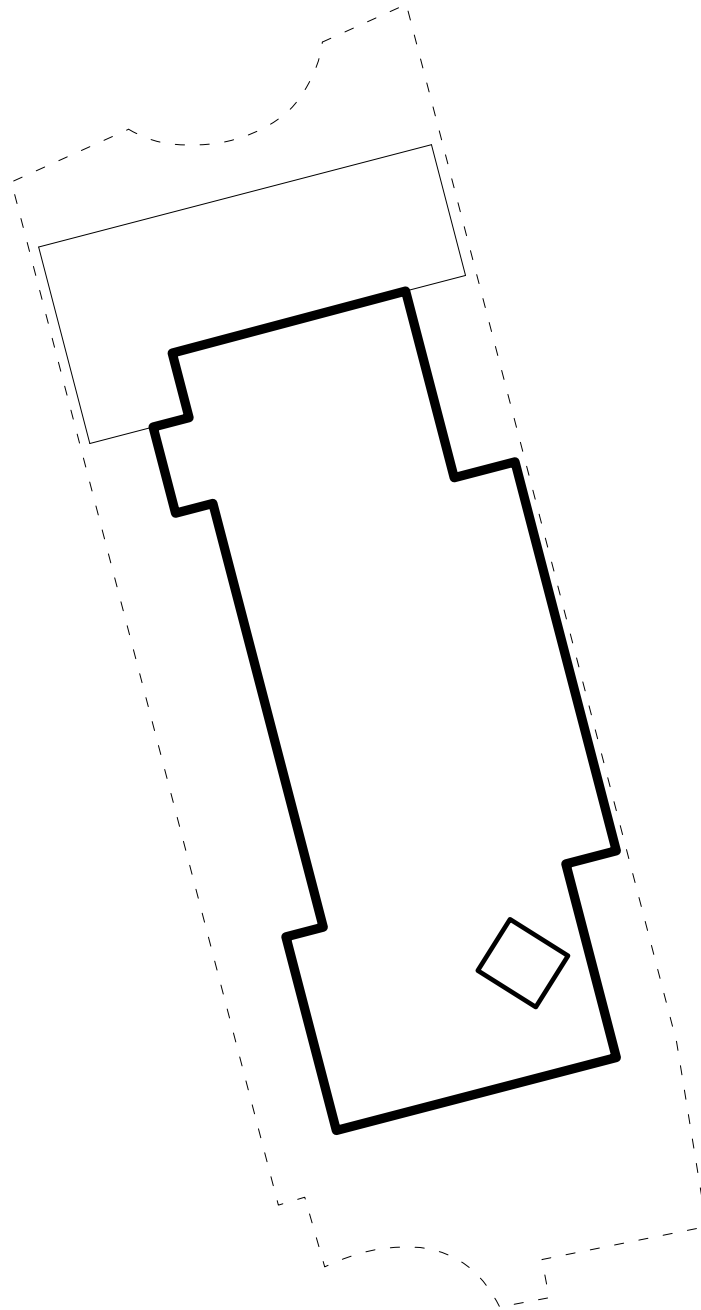

#099 - Gagliano del Capo - Via del Mare, 4

Orientation

Attached Semi Detached



Shape

Box Curvy Geometric



Yard

Front Back None



Borders

Fence Wall None



Parking

Drive Street None



Stairs

Yes No



Site Plan

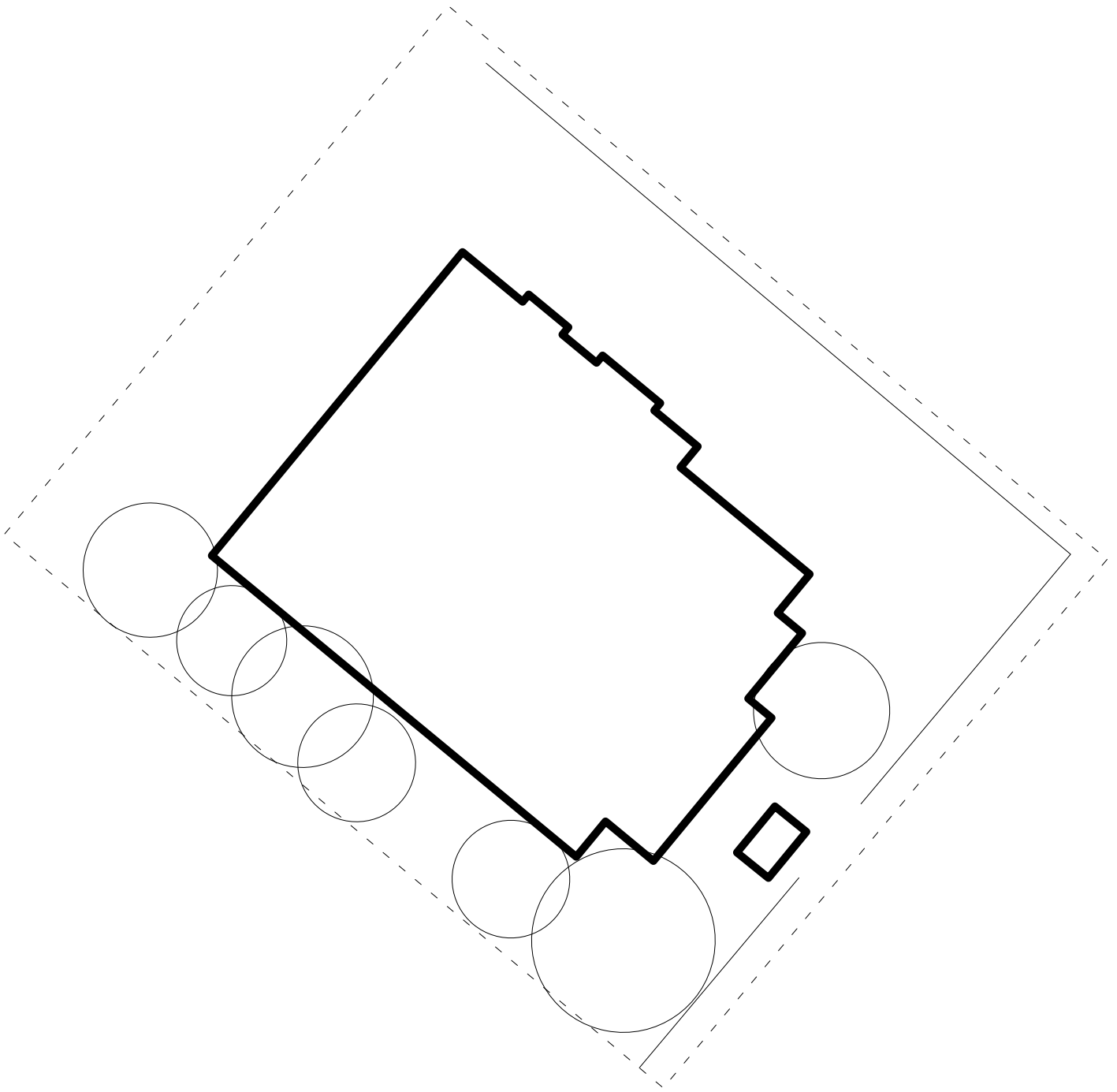

#423 - Taurisano - 8 Via Piero Gobetti

Orientation

Attached Semi Detached

<input type="checkbox"/>	<input checked="" type="checkbox"/>	<input type="checkbox"/>
--------------------------	-------------------------------------	--------------------------

Shape

Box Curvy Geometric

<input checked="" type="checkbox"/>	<input type="checkbox"/>	<input type="checkbox"/>
-------------------------------------	--------------------------	--------------------------

Yard

Front Back None

<input checked="" type="checkbox"/>	<input type="checkbox"/>	<input type="checkbox"/>
-------------------------------------	--------------------------	--------------------------

Borders

Fence Wall None

<input checked="" type="checkbox"/>	<input type="checkbox"/>	<input type="checkbox"/>
-------------------------------------	--------------------------	--------------------------

Parking

Drive Street None

<input checked="" type="checkbox"/>	<input type="checkbox"/>	<input type="checkbox"/>
-------------------------------------	--------------------------	--------------------------

Stairs

Yes No

<input type="checkbox"/>	<input checked="" type="checkbox"/>
--------------------------	-------------------------------------

Site Plan

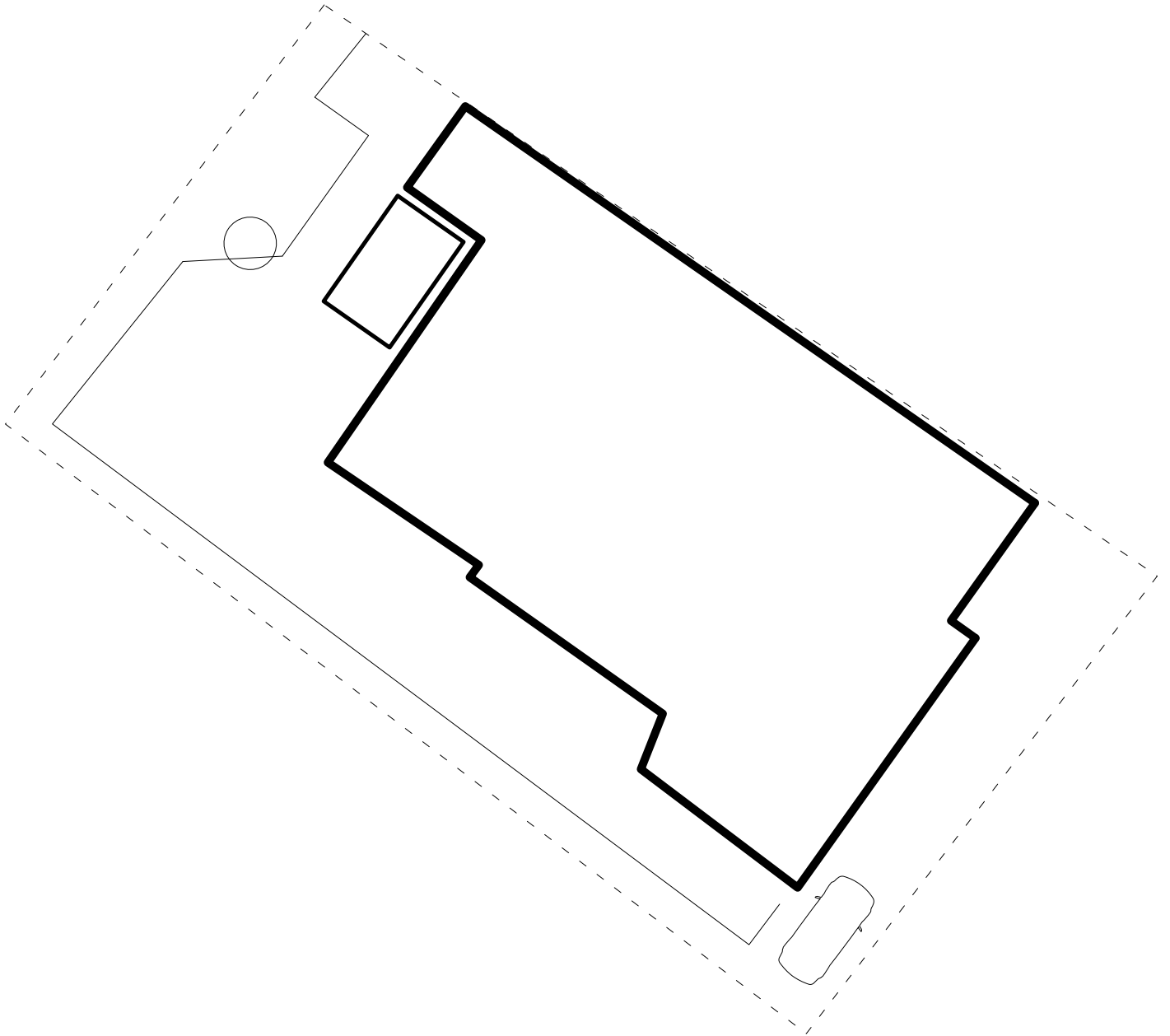

#117 - Lecce - Via Archimede, 1

Orientation

Attached Semi Detached



Shape

Box Curvy Geometric



Yard

Front Back None



Borders

Fence Wall None



Parking

Drive Street None



Stairs

Yes No



Site Plan

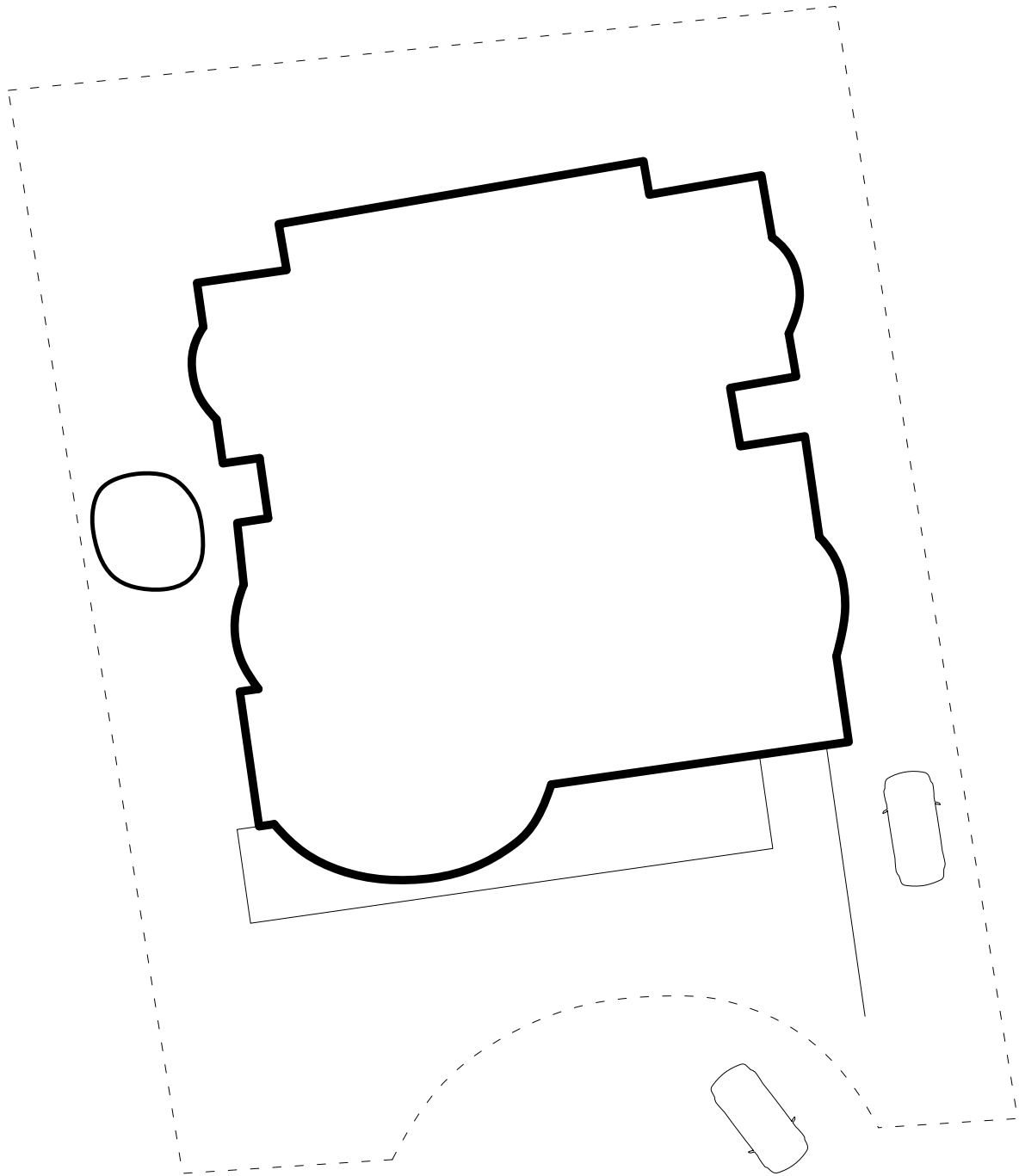

#107 - Gallipoli - Via Elia Franich, 7

Orientation

Attached Semi Detached



Shape

Box Curvy Geometric



Yard

Front Back None



Borders

Fence Wall None



Parking

Drive Street None



Stairs

Yes No



Site Plan

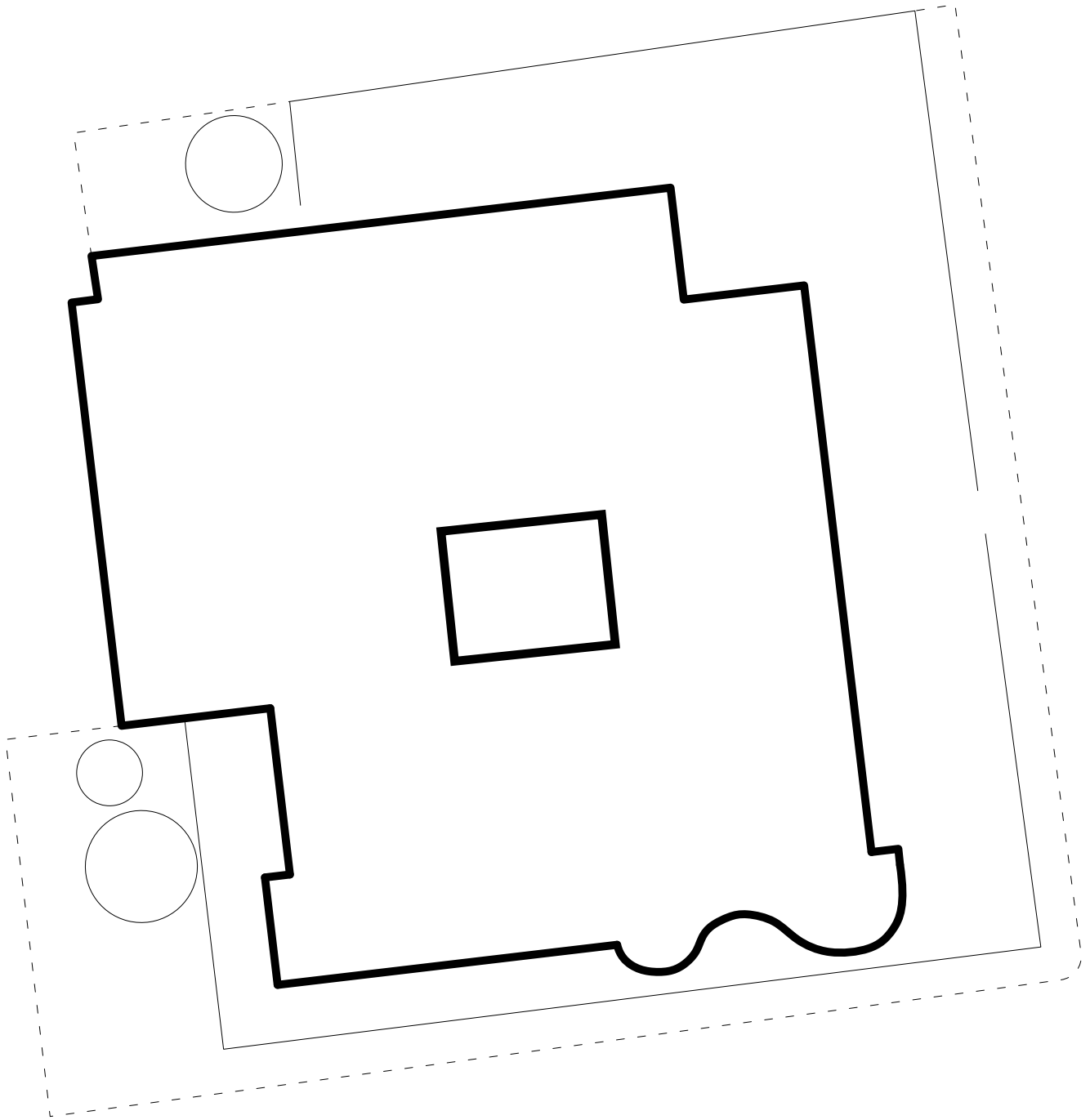

#134 - Leverano - 1 Via Giuseppe Giusti

Orientation

Attached Semi Detached



Shape

Box Curvy Geometric



Yard

Front Back None



Borders

Fence Wall None



Parking

Drive Street None



Stairs

Yes No



Site Plan

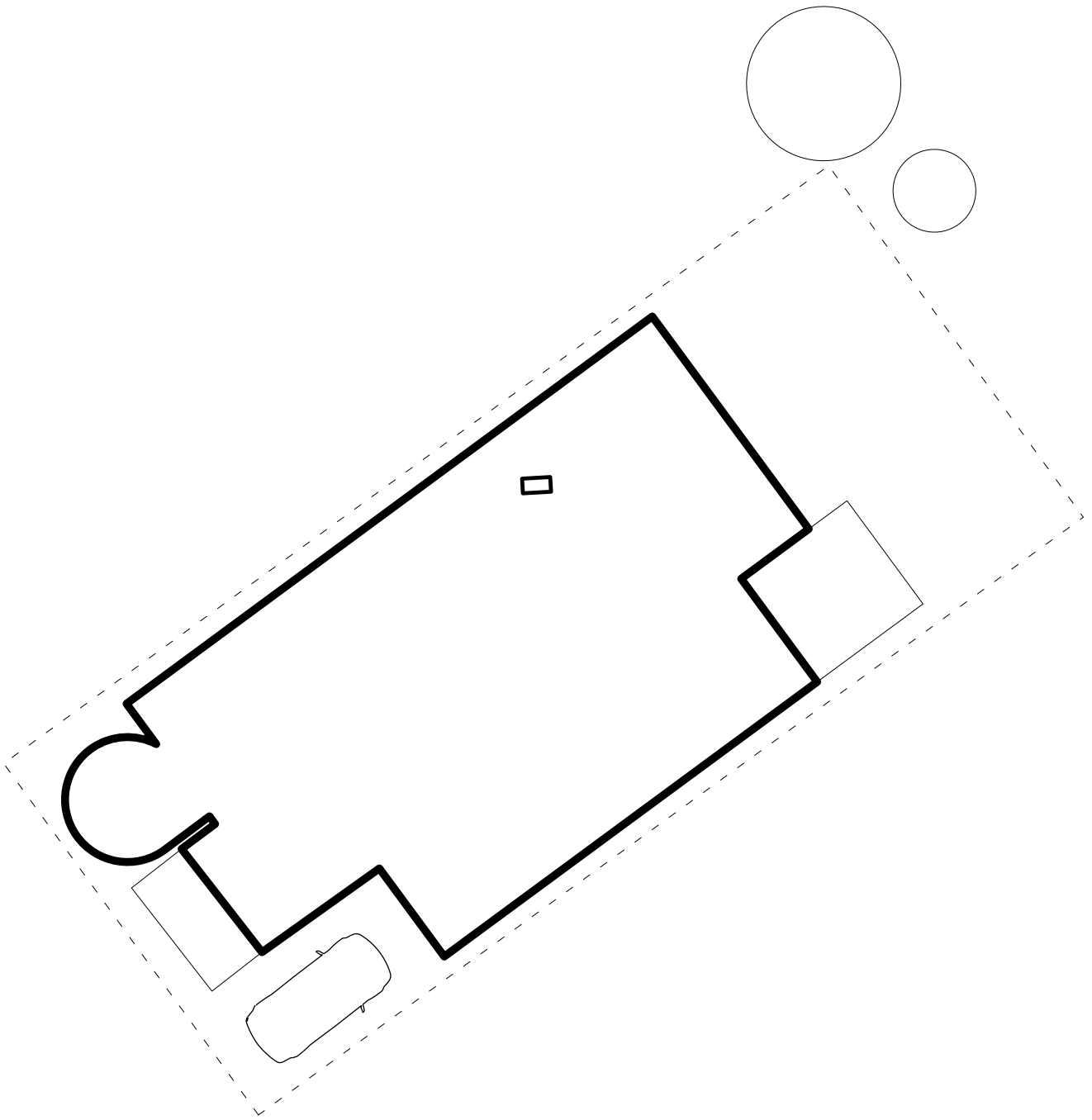

#451 - Torre San Giovanni - Via B. Il Corsaro, 36

Orientation

Attached Semi Detached

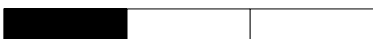

Shape

Box Curvy Geometric



Yard

Front Back None



Borders

Fence Wall None



Parking

Drive Street None



Stairs

Yes No



Site Plan

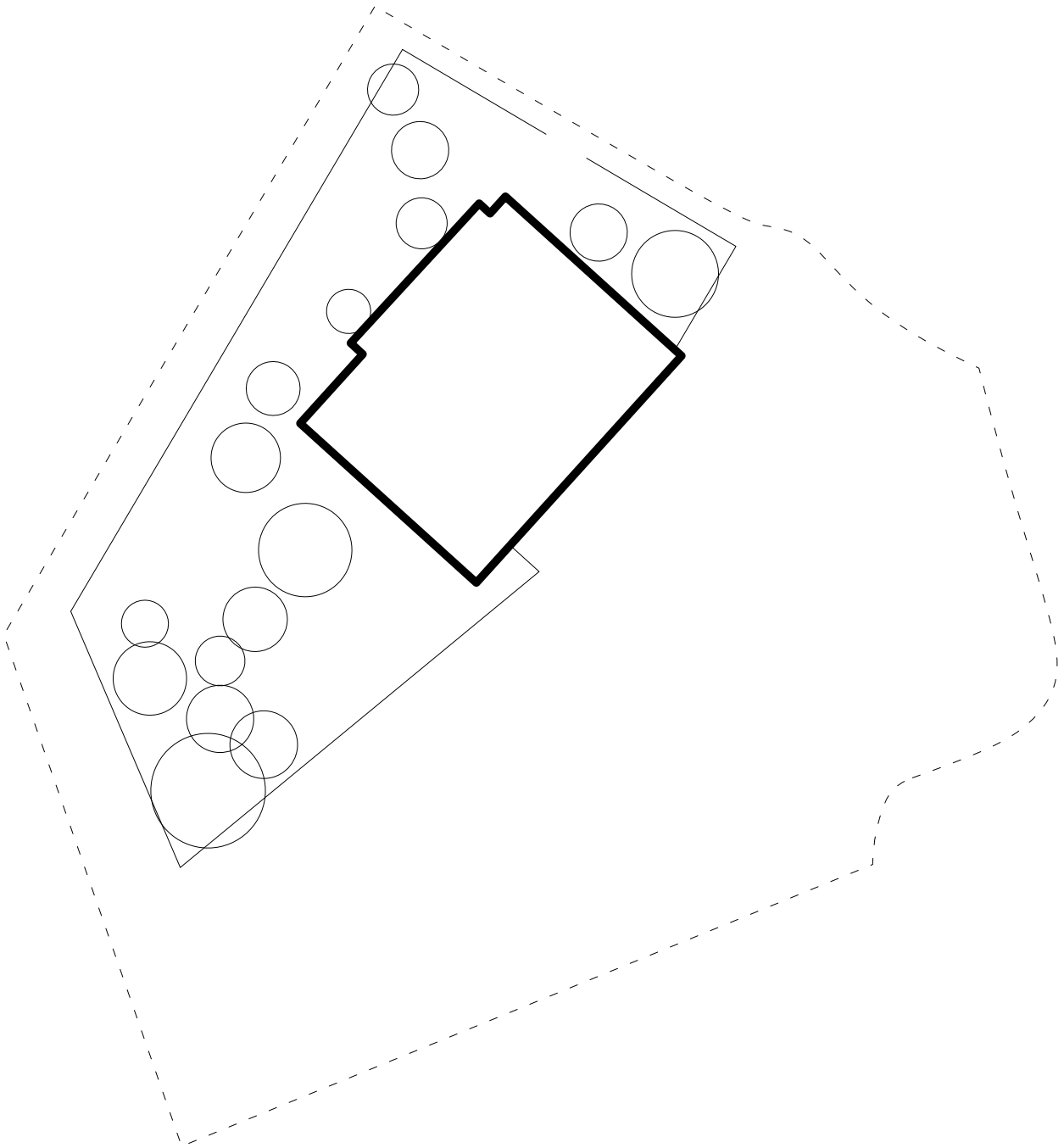

#428 - Taurisano - Via A. Meucci, 18

Orientation

Attached Semi Detached

<input type="checkbox"/>	<input type="checkbox"/>	<input checked="" type="checkbox"/>
--------------------------	--------------------------	-------------------------------------

Shape

Box Curvy Geometric

<input checked="" type="checkbox"/>	<input type="checkbox"/>	<input type="checkbox"/>
-------------------------------------	--------------------------	--------------------------

Yard

Front Back None

<input checked="" type="checkbox"/>	<input type="checkbox"/>	<input type="checkbox"/>
-------------------------------------	--------------------------	--------------------------

Borders

Fence Wall None

<input checked="" type="checkbox"/>	<input type="checkbox"/>	<input type="checkbox"/>
-------------------------------------	--------------------------	--------------------------

Parking

Drive Street None

<input checked="" type="checkbox"/>	<input type="checkbox"/>	<input type="checkbox"/>
-------------------------------------	--------------------------	--------------------------

Stairs

Yes No

<input checked="" type="checkbox"/>	<input type="checkbox"/>
-------------------------------------	--------------------------

Site Plan

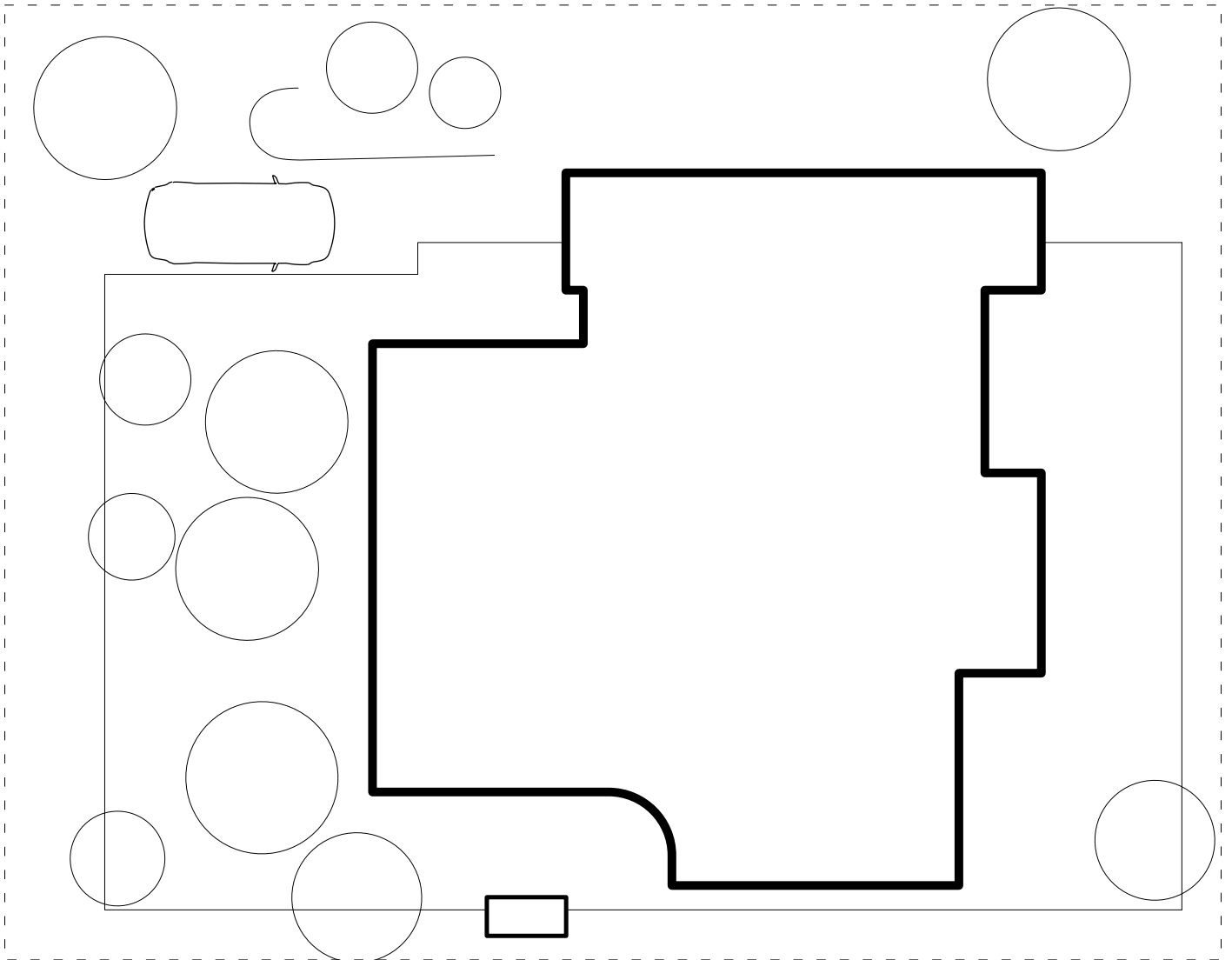

#456 - Tricase - Via Costanzo Varolio, 1

Orientation

Attached Semi Detached



Shape

Box Curvy Geometric



Yard

Front Back None



Borders

Fence Wall None



Parking

Drive Street None



Stairs

Yes No



Site Plan

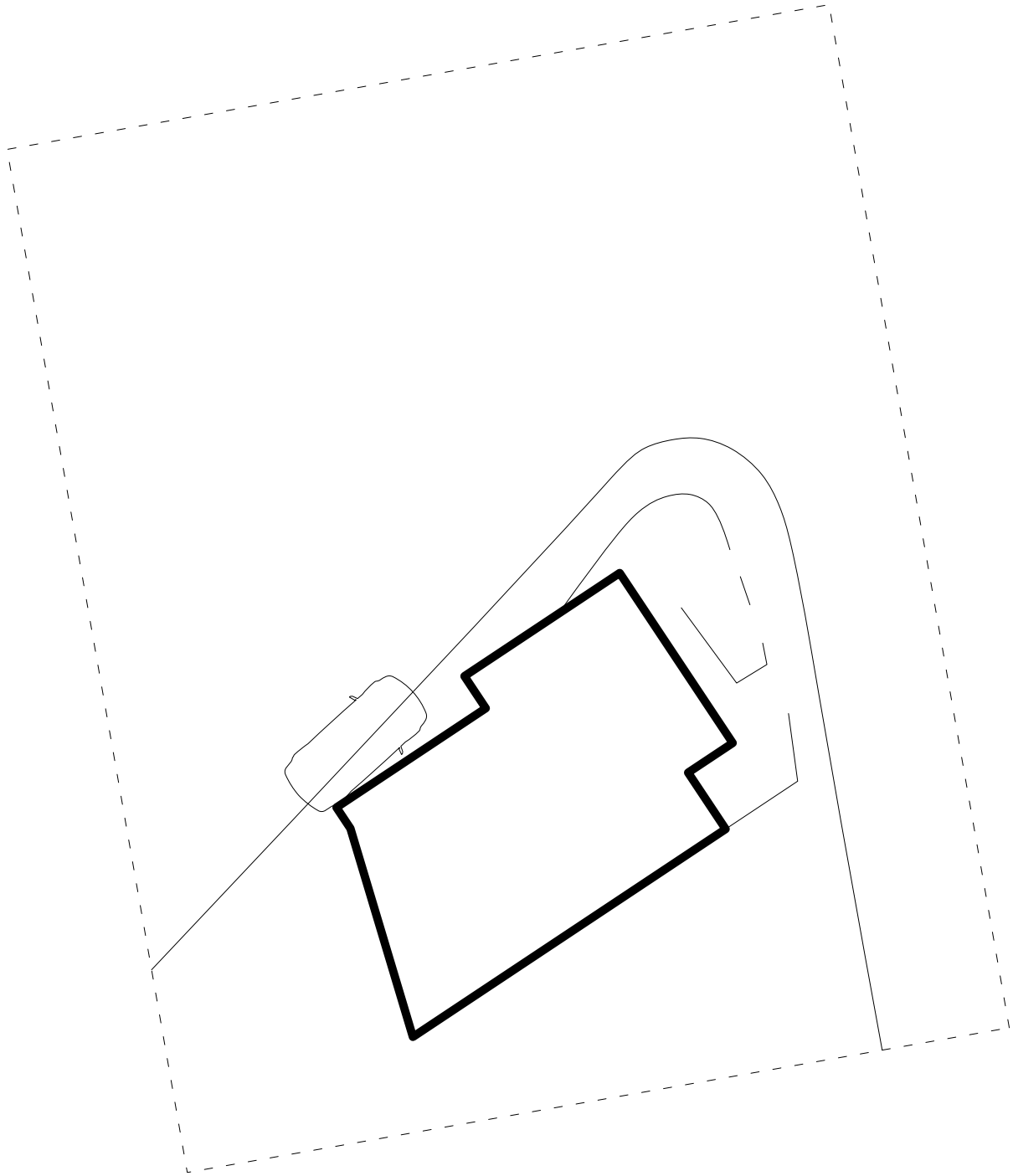

#450 - Torre San Giovanni - Via G. da Verrazzano, 26

Orientation

Attached Semi Detached



Shape

Box Curvy Geometric



Yard

Front Back None



Borders

Fence Wall None



Parking

Drive Street None



Stairs

Yes No



Site Plan

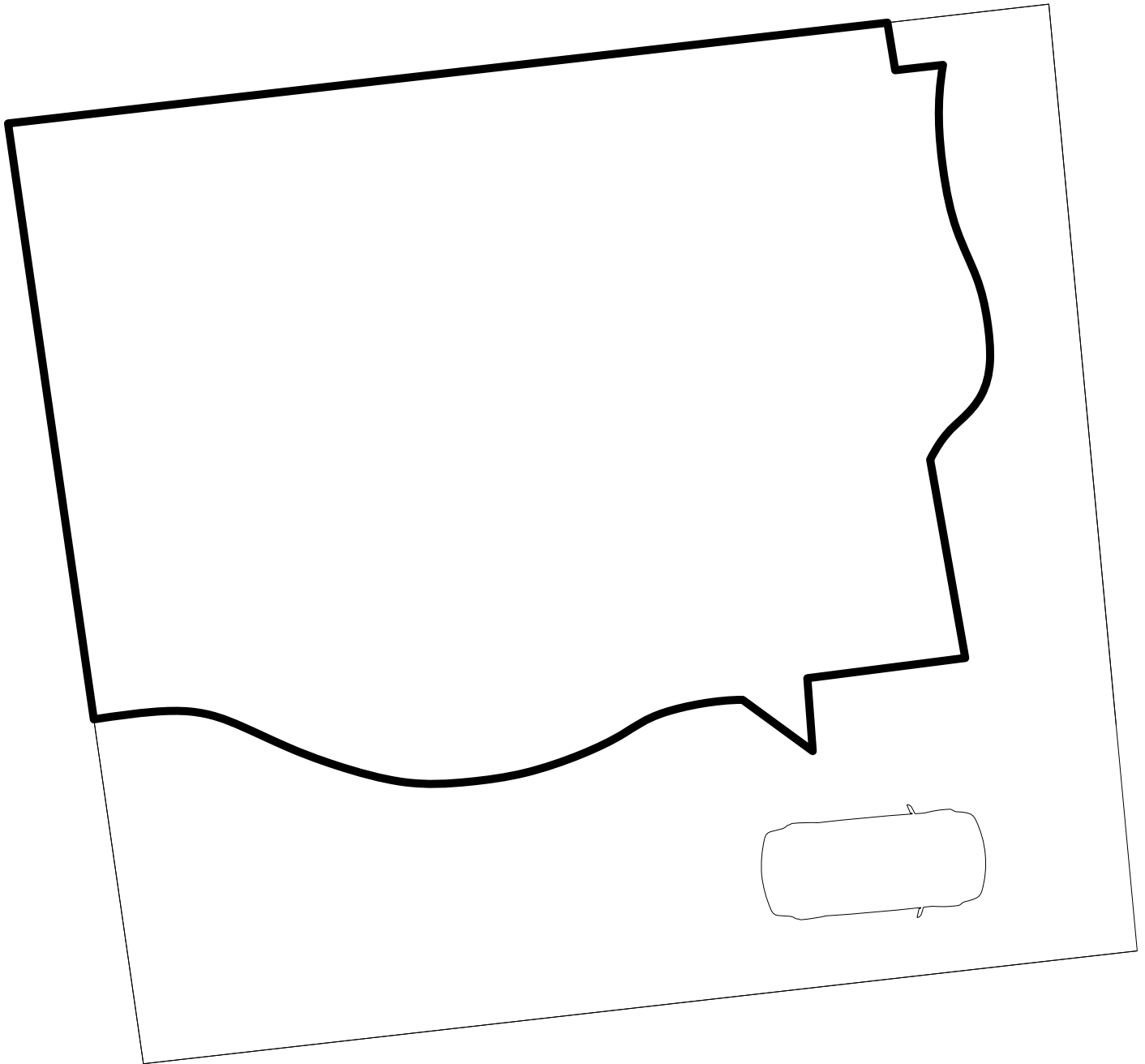

#197 - Minervino di Lecce - Via Indipendenza

Orientation

Attached Semi Detached

<input type="checkbox"/>	<input type="checkbox"/>	<input checked="" type="checkbox"/>
--------------------------	--------------------------	-------------------------------------

Shape

Box Curvy Geometric

<input type="checkbox"/>	<input checked="" type="checkbox"/>	<input type="checkbox"/>
--------------------------	-------------------------------------	--------------------------

Yard

Front Back None

<input checked="" type="checkbox"/>	<input type="checkbox"/>	<input type="checkbox"/>
-------------------------------------	--------------------------	--------------------------

Borders

Fence Wall None

<input checked="" type="checkbox"/>	<input type="checkbox"/>	<input type="checkbox"/>
-------------------------------------	--------------------------	--------------------------

Parking

Drive Street None

<input checked="" type="checkbox"/>	<input type="checkbox"/>
-------------------------------------	--------------------------

Stairs

Yes No

<input type="checkbox"/>	<input checked="" type="checkbox"/>
--------------------------	-------------------------------------

Site Plan

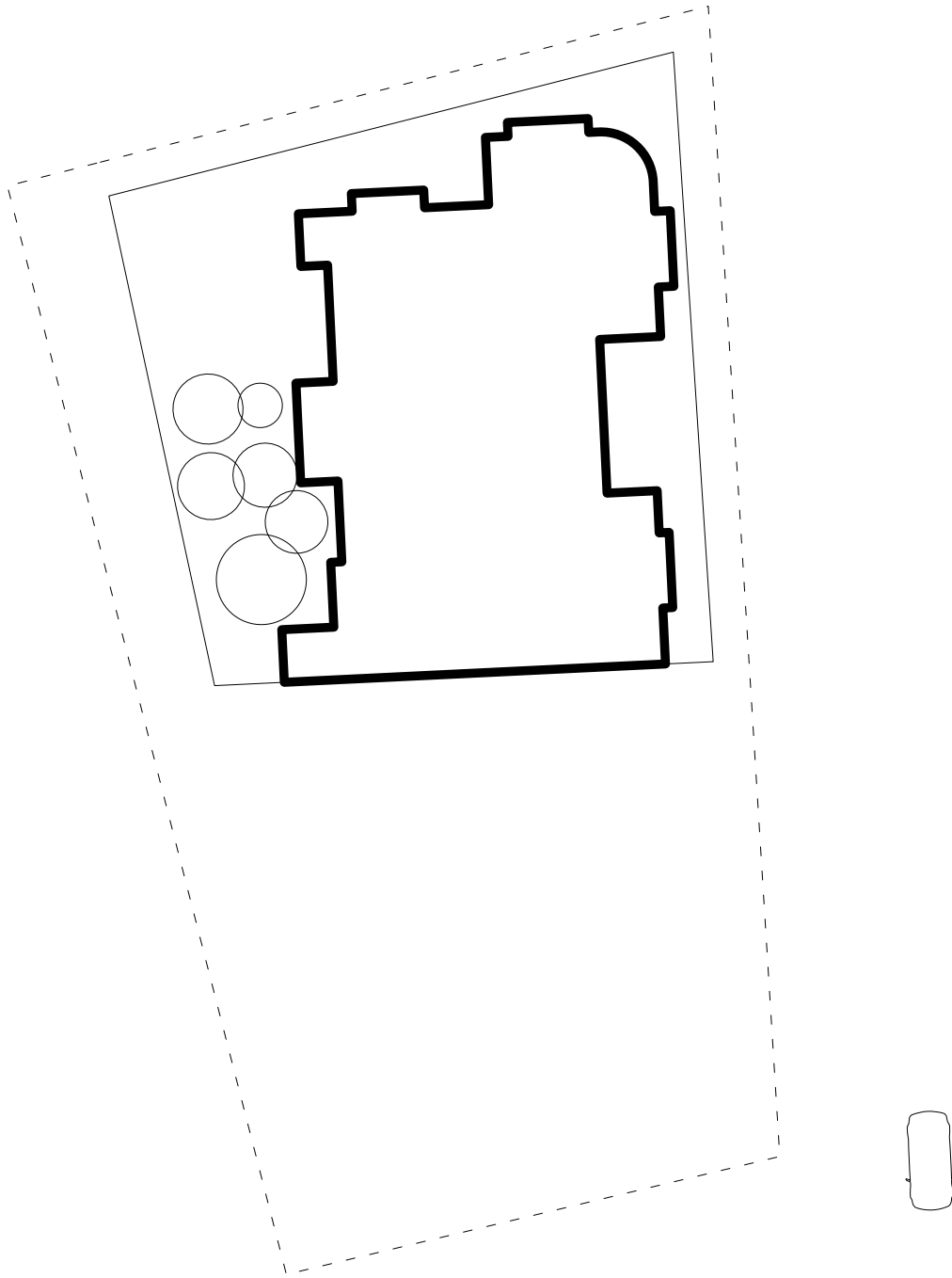

#142 - Leverano - Via C. Menotti, 56

Orientation

Attached Semi Detached



Shape

Box Curvy Geometric



Yard

Front Back None



Borders

Fence Wall None



Parking

Drive Street None



Stairs

Yes No



Site Plan

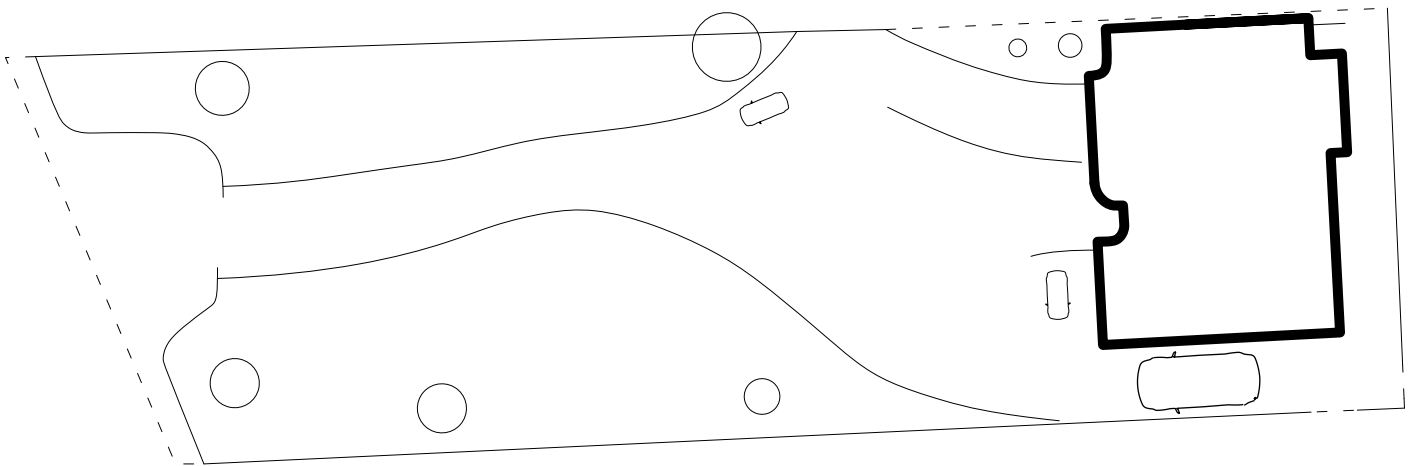

#168 - Melendugno - Via Tancredi D'Alta Villa, 25

Orientation

Attached Semi Detached



Shape

Box Curvy Geometric



Yard

Front Back None



Borders

Fence Wall None



Parking

Drive Street None



Stairs

Yes No



Site Plan

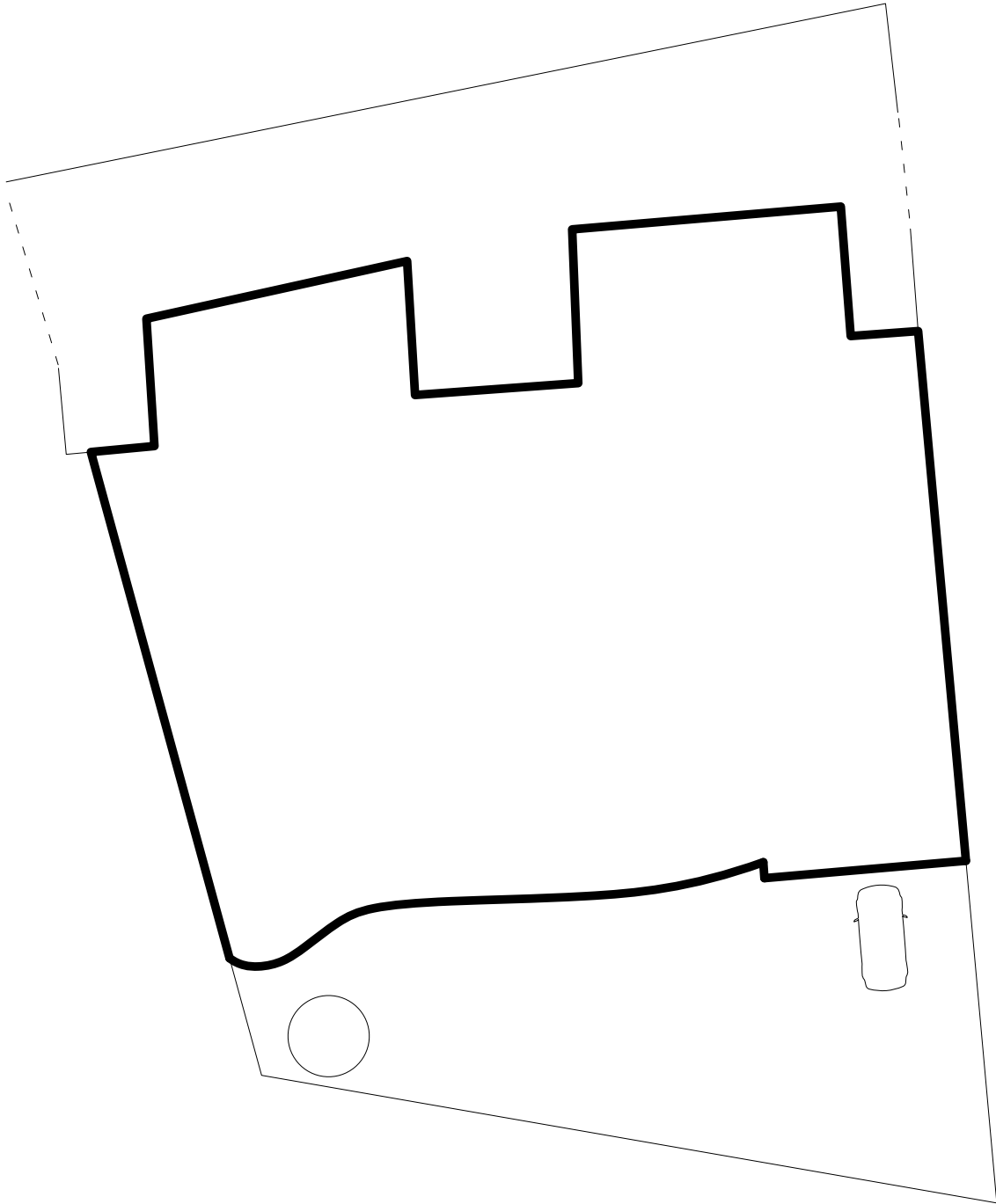

#176 - Melendugno - 35 Via S. Antonio

Orientation

Attached Semi Detached



Shape

Box Curvy Geometric



Yard

Front Back None



Borders

Fence Wall None



Parking

Drive Street None



Stairs

Yes No



Site Plan

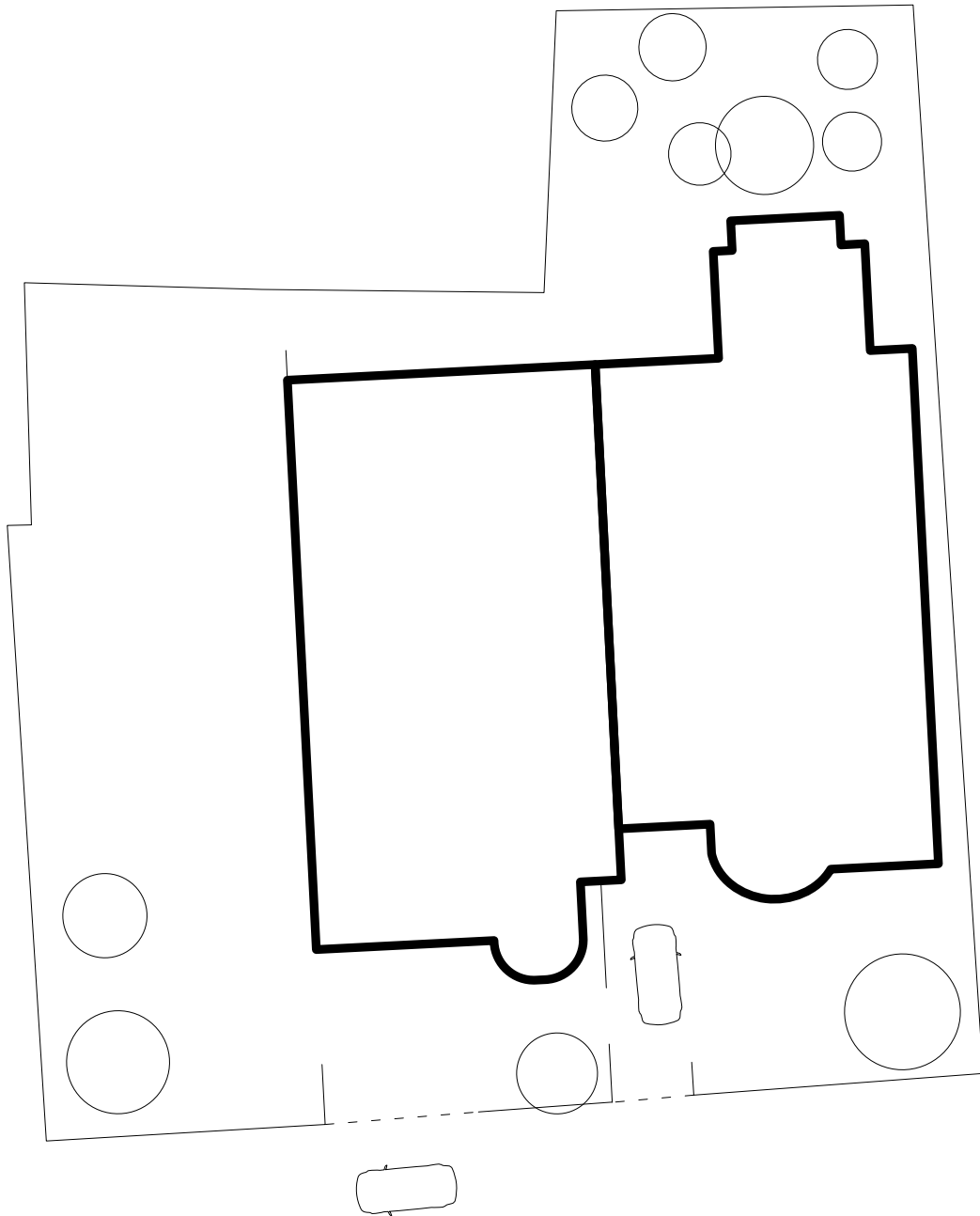

#224 - Moteroni di Lecce - Via Tito Scipa, 17

Orientation

Attached Semi Detached



Shape

Box Curvy Geometric



Yard

Front Back None



Borders

Fence Wall None



Parking

Drive Street None



Stairs

Yes No



Site Plan

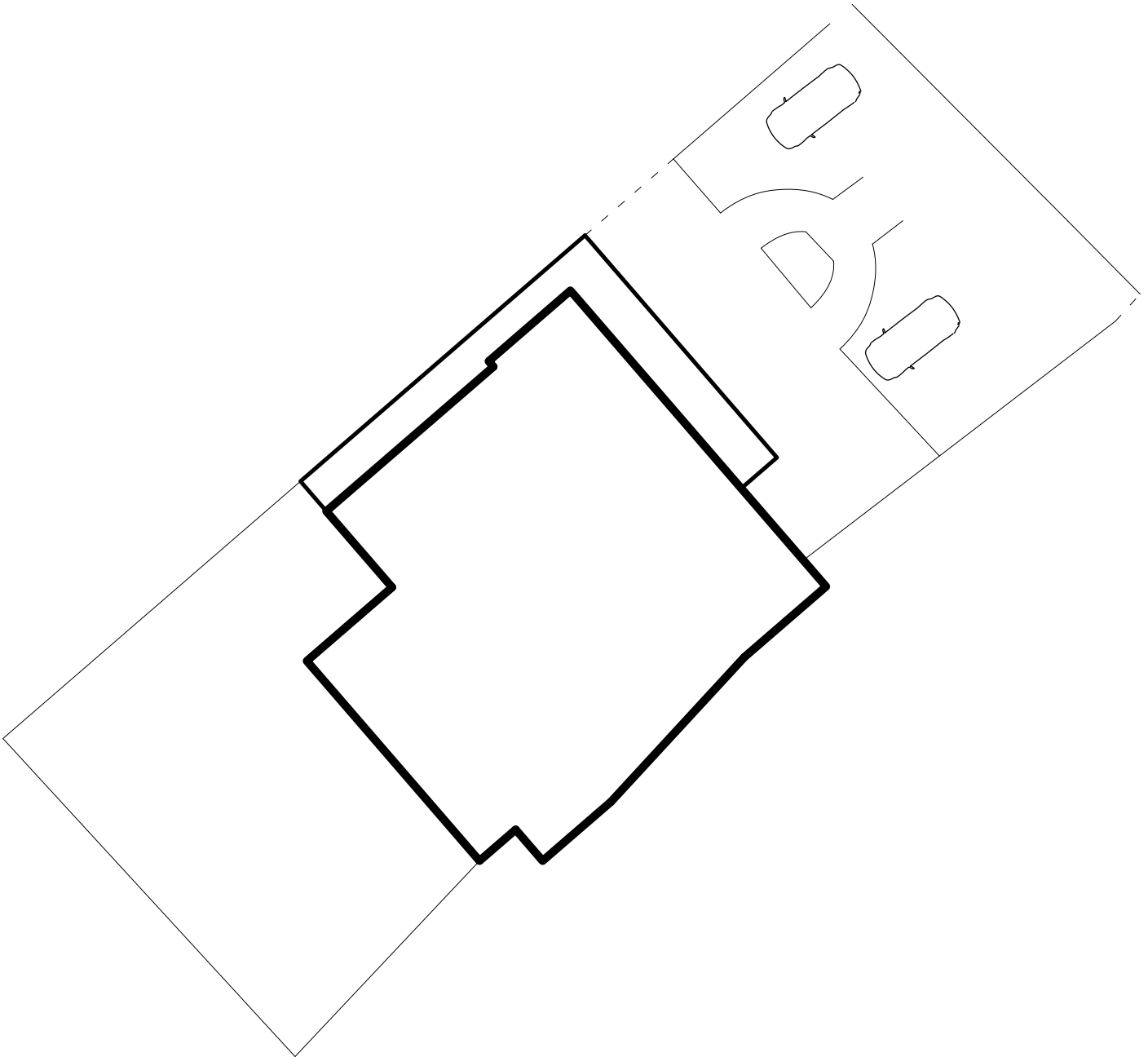

#460 - Tricase - Via Antonio Maria Valsalva, 33

Orientation

Attached Semi Detached



Shape

Box Curvy Geometric



Yard

Front Back None



Borders

Fence Wall None



Parking

Drive Street None



Stairs

Yes No



Site Plan

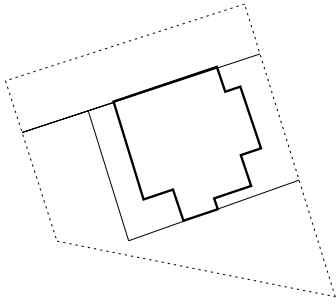

#020

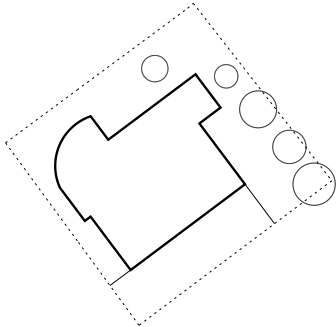
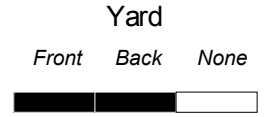
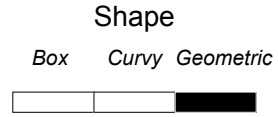
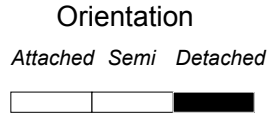

#032

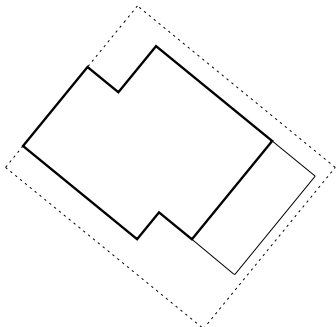
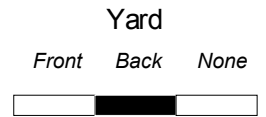
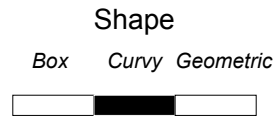
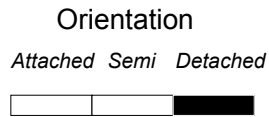

#066

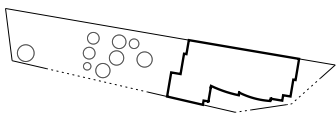
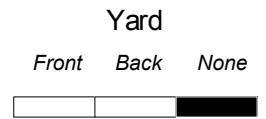
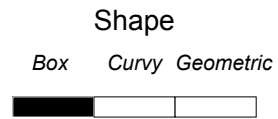
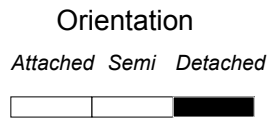

#193

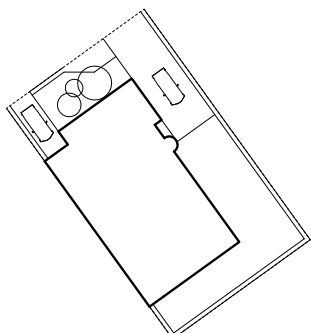
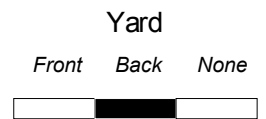
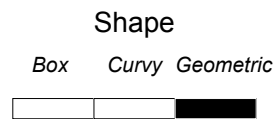
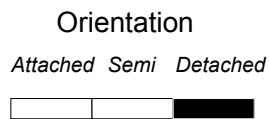

#476

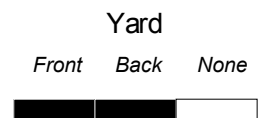
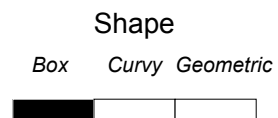
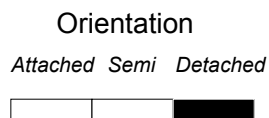

Site Plan

Borders

Fence Wall None



Parking

Drive Street None



Stairs

Yes No

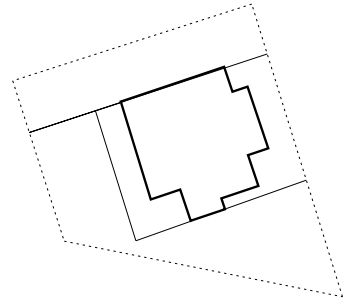

#020

Borders

Fence Wall None



Parking

Drive Street None

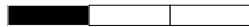

Stairs

Yes No

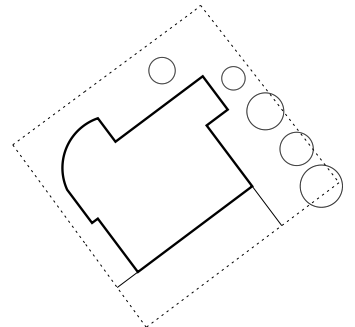

#032

Borders

Fence Wall None



Parking

Drive Street None



Stairs

Yes No

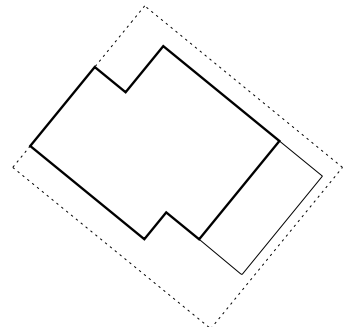

#066

Borders

Fence Wall None



Parking

Drive Street None

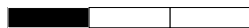

Stairs

Yes No

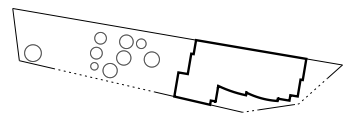

#193

Borders

Fence Wall None



Parking

Drive Street None



Stairs

Yes No

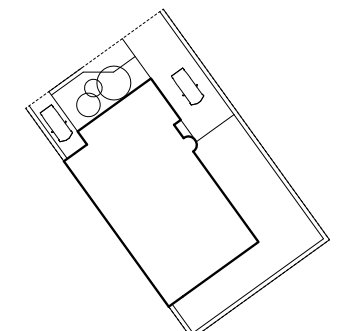

#476

Site Plan

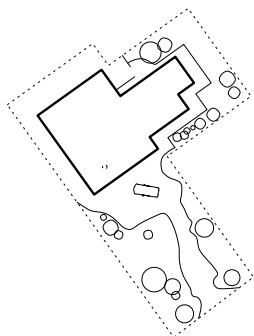

#033

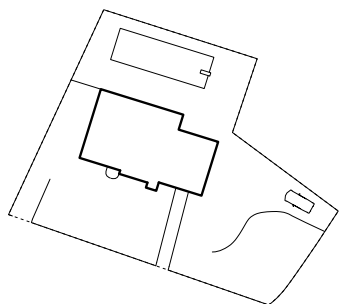
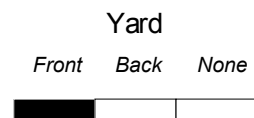
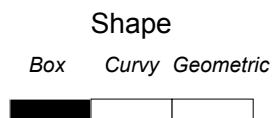
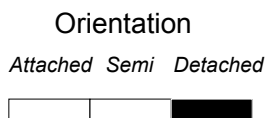

#028

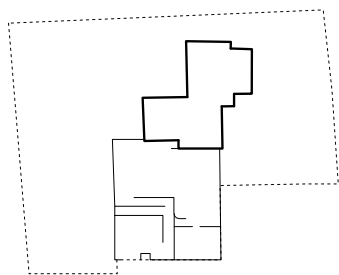
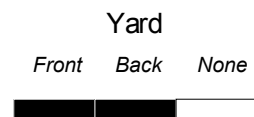
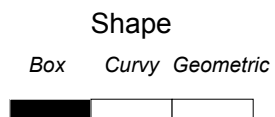
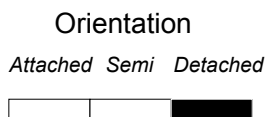

#026

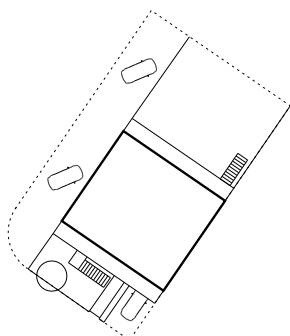
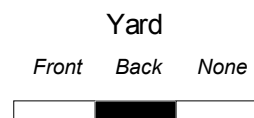
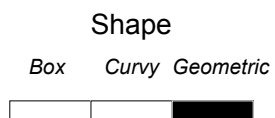
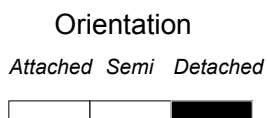

#483

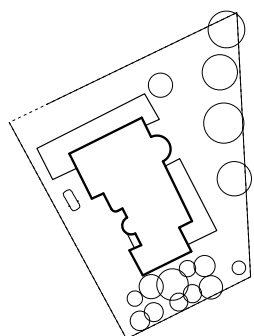
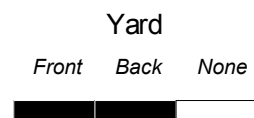
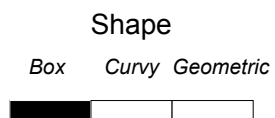
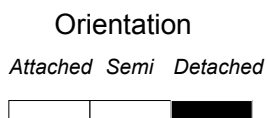

#152

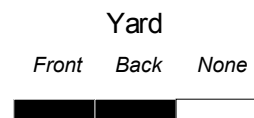
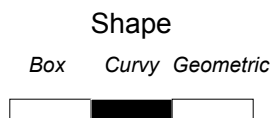
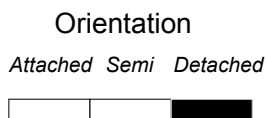

Site Plan

Borders

Fence Wall None



Parking

Drive Street None



Stairs

Yes No

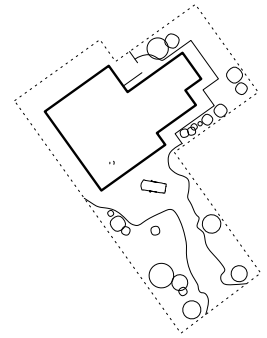

#033

Borders

Fence Wall None



Parking

Drive Street None

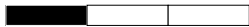

Stairs

Yes No

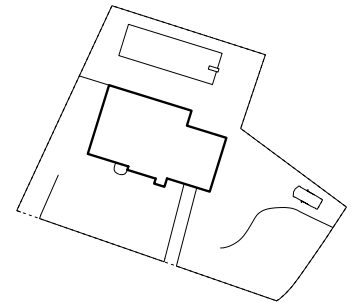

#028

Borders

Fence Wall None



Parking

Drive Street None



Stairs

Yes No

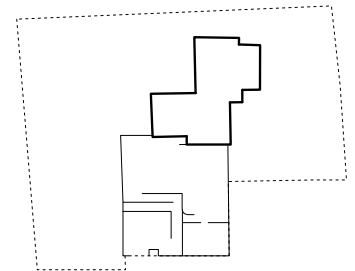

#026

Borders

Fence Wall None



Parking

Drive Street None



Stairs

Yes No

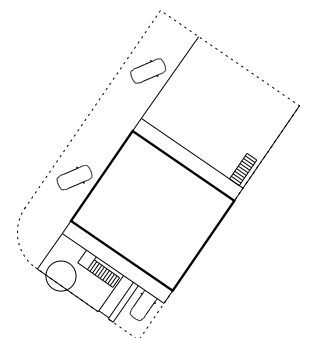

#483

Borders

Fence Wall None



Parking

Drive Street None



Stairs

Yes No

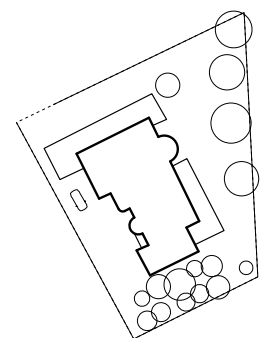

#152

Site Plan

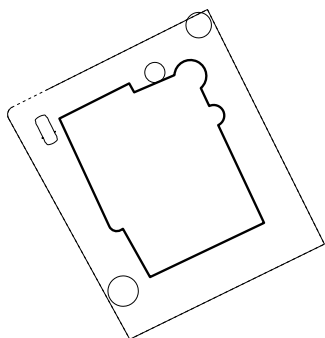

#154

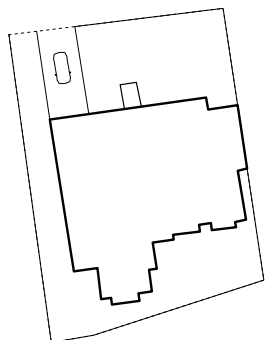
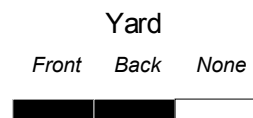
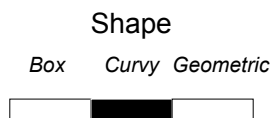
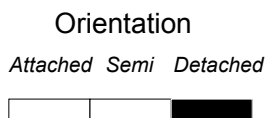

#189

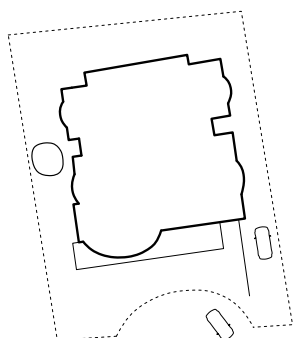
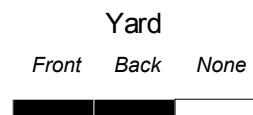
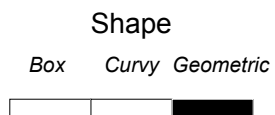
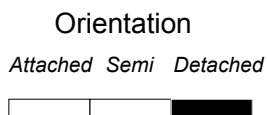

#107

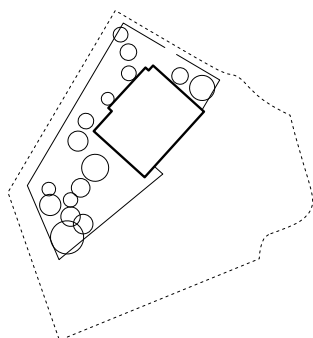
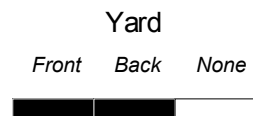
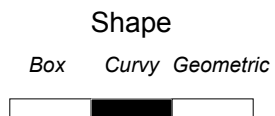
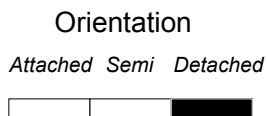

#428

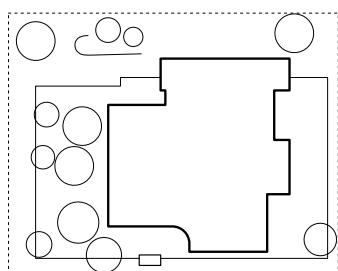
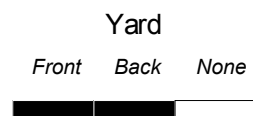
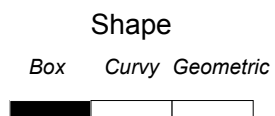
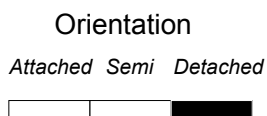

#456

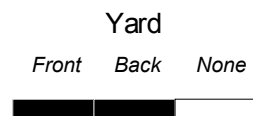
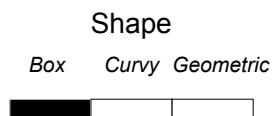
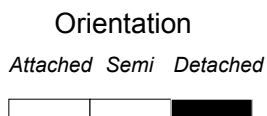

Site Plan

Borders

Fence Wall None



Parking

Drive Street None



Stairs

Yes No

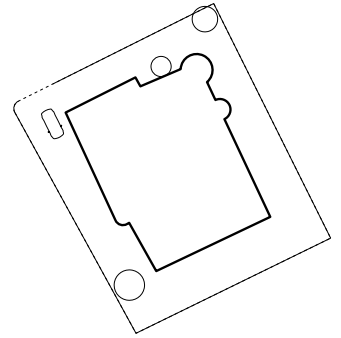

#154

Borders

Fence Wall None

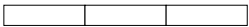

Parking

Drive Street None

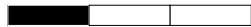

Stairs

Yes No

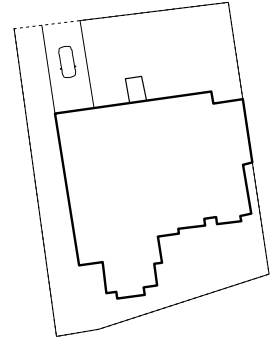

#189

Borders

Fence Wall None

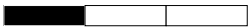

Parking

Drive Street None



Stairs

Yes No

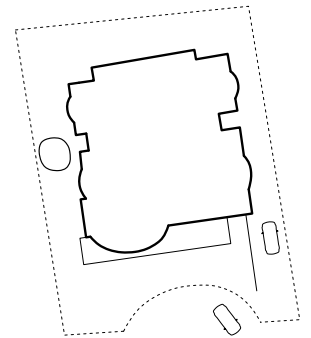

#107

Borders

Fence Wall None

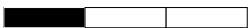

Parking

Drive Street None



Stairs

Yes No

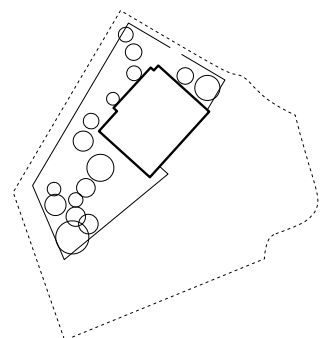

#428

Borders

Fence Wall None



Parking

Drive Street None



Stairs

Yes No

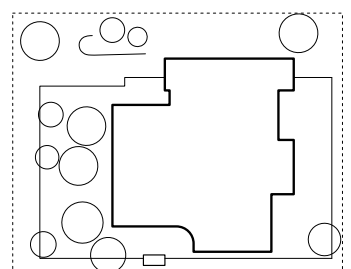

#456

Site Plan

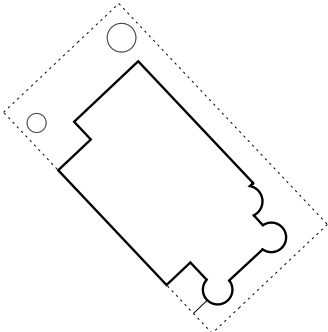

#230

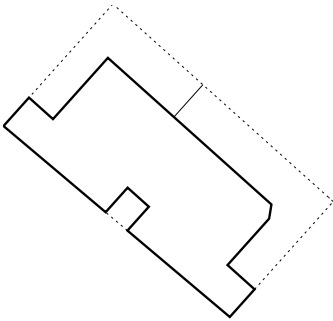
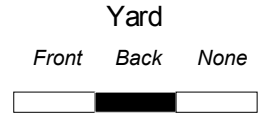
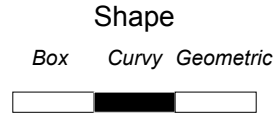
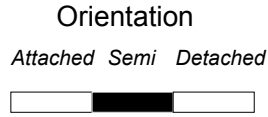

#461

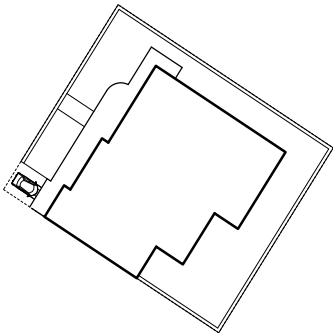
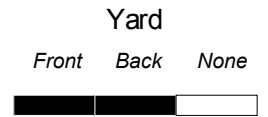
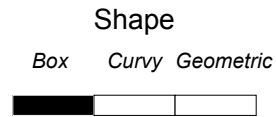
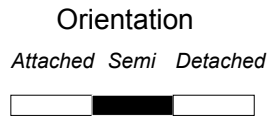

#487

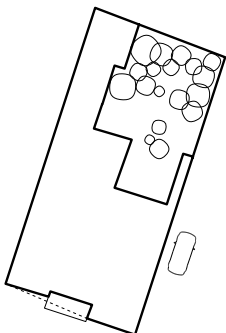
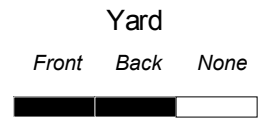
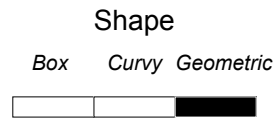
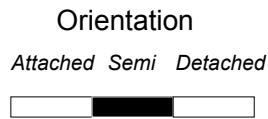

#005

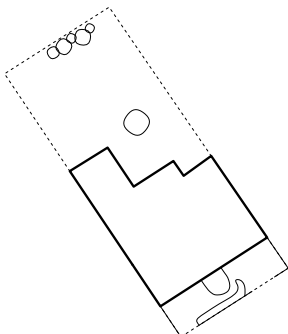
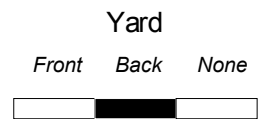
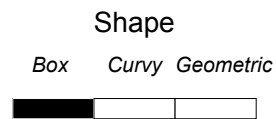
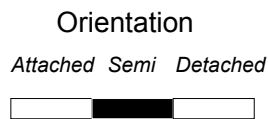

#007

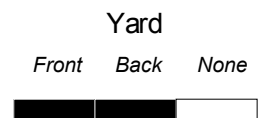
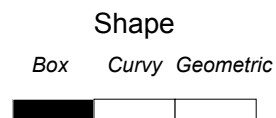
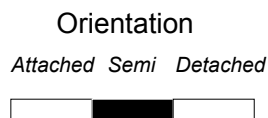

Site Plan

Borders

Fence Wall None

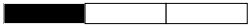

Parking

Drive Street None



Stairs

Yes No

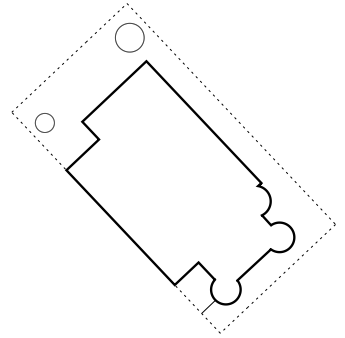

#230

Borders

Fence Wall None

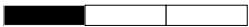

Parking

Drive Street None

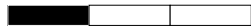

Stairs

Yes No

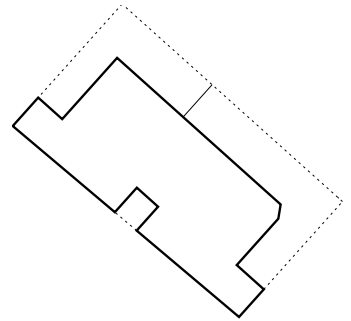

#461

Borders

Fence Wall None



Parking

Drive Street None

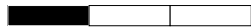

Stairs

Yes No

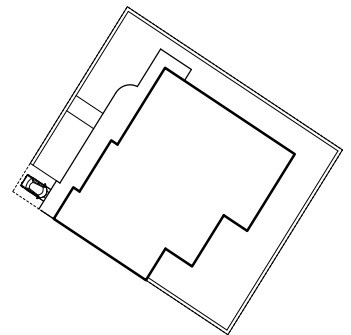

#487

Borders

Fence Wall None

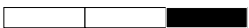

Parking

Drive Street None



Stairs

Yes No

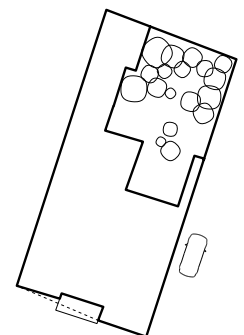

#005

Borders

Fence Wall None



Parking

Drive Street None



Stairs

Yes No

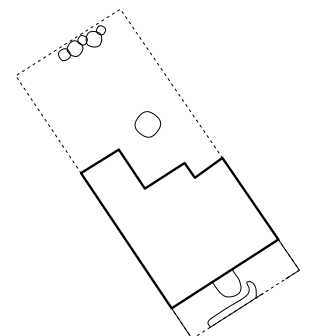

#007

Site Plan

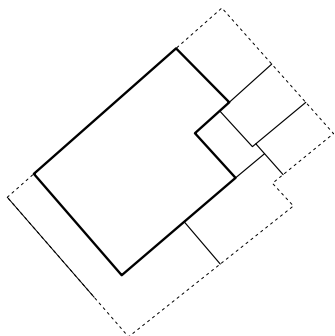

#071

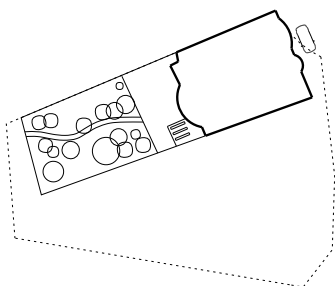
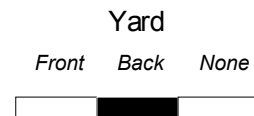
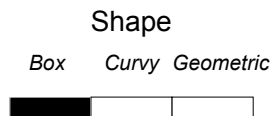
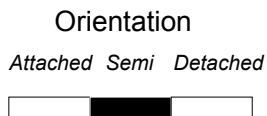

#494

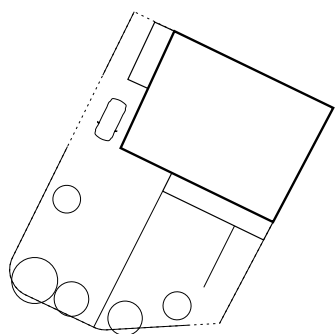
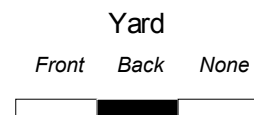
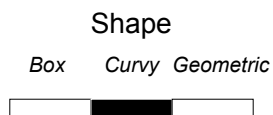
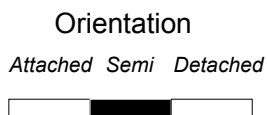

#145

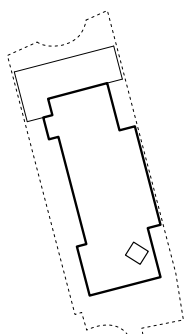
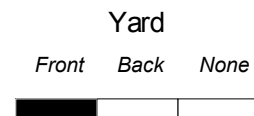
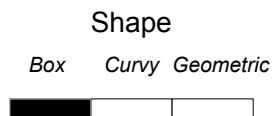
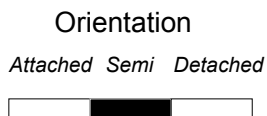

#099

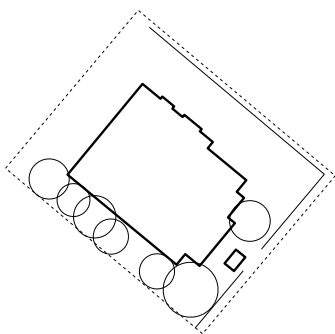
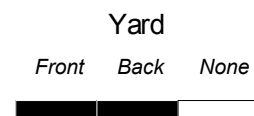
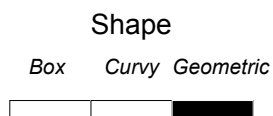
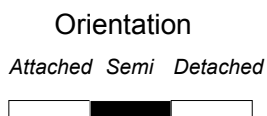

#423

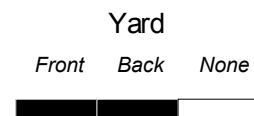
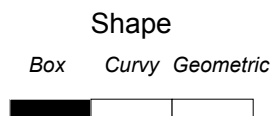
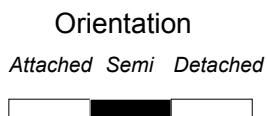

Site Plan

Borders

Fence Wall None



Parking

Drive Street None



Stairs

Yes No

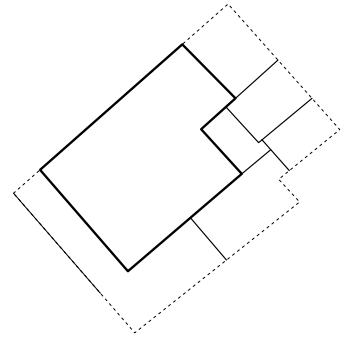

#071

Borders

Fence Wall None

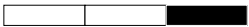

Parking

Drive Street None



Stairs

Yes No

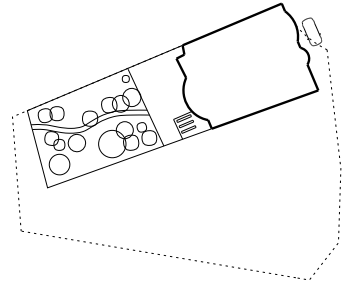

#494

Borders

Fence Wall None



Parking

Drive Street None

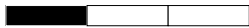

Stairs

Yes No

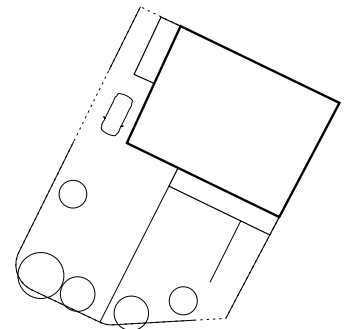

#145

Borders

Fence Wall None

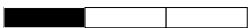

Parking

Drive Street None



Stairs

Yes No

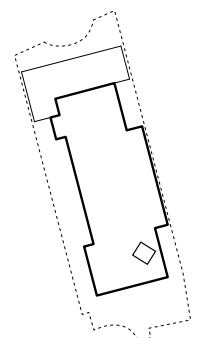

#099

Borders

Fence Wall None



Parking

Drive Street None



Stairs

Yes No

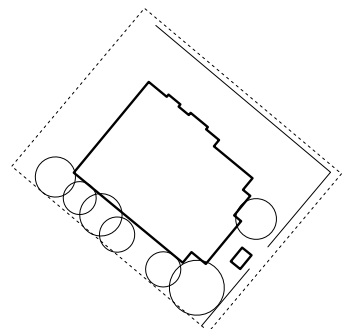

#423

Site Plan

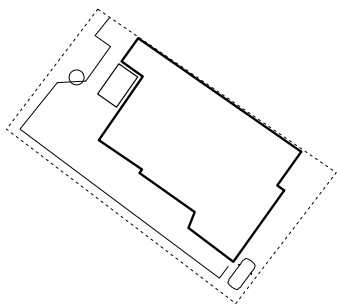

#117

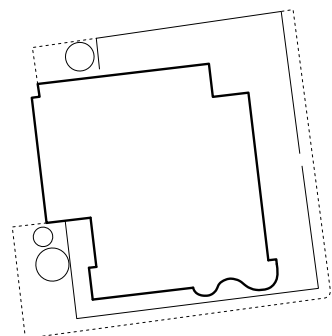
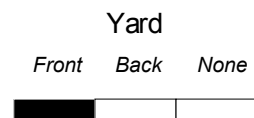
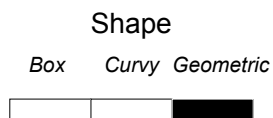
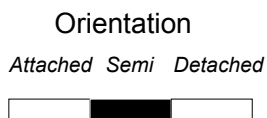

#134

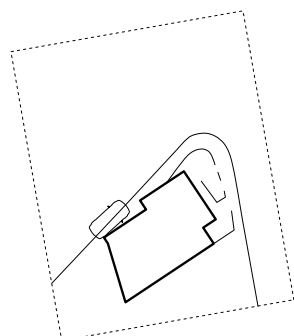
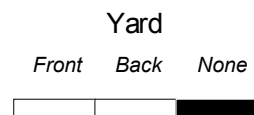
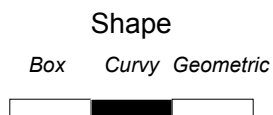
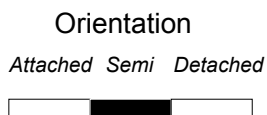

#450

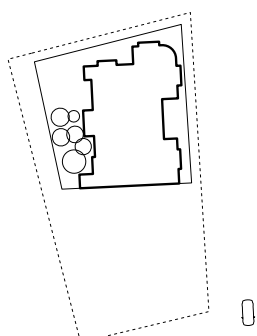
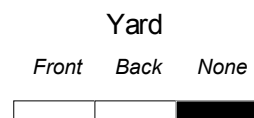
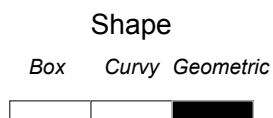
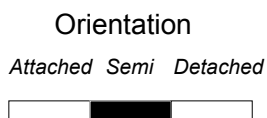

#142

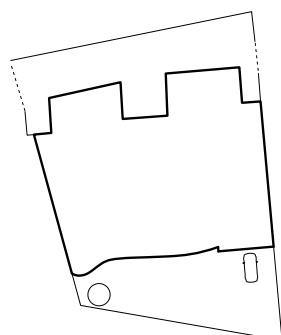
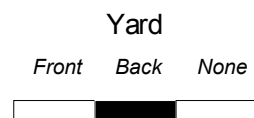
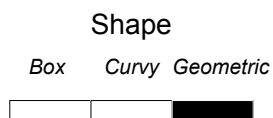
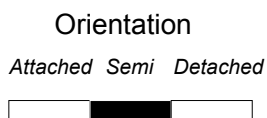

#176

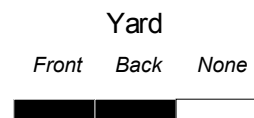
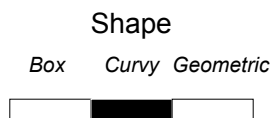
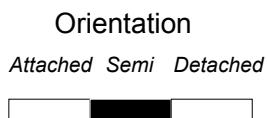

Site Plan

Borders

Fence Wall None



Parking

Drive Street None



Stairs

Yes No

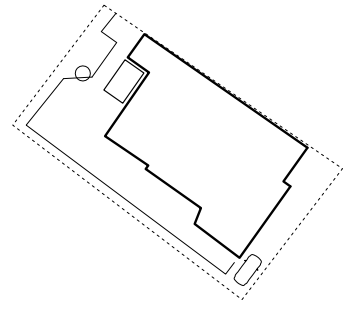

#117

Borders

Fence Wall None



Parking

Drive Street None



Stairs

Yes No

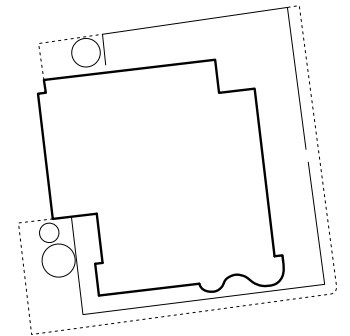

#134

Borders

Fence Wall None

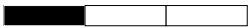

Parking

Drive Street None

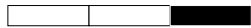

Stairs

Yes No

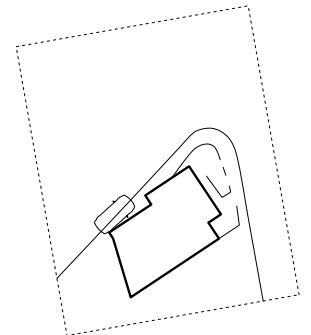

#450

Borders

Fence Wall None

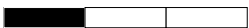

Parking

Drive Street None



Stairs

Yes No

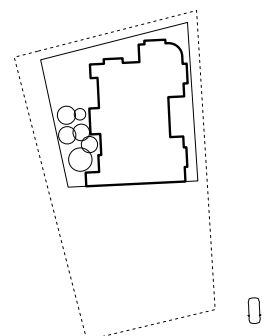

#142

Borders

Fence Wall None



Parking

Drive Street None



Stairs

Yes No

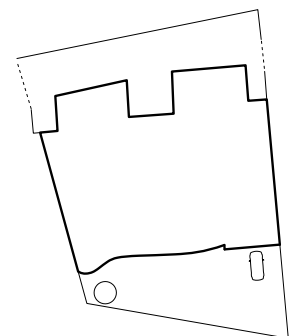

#176

Site Plan

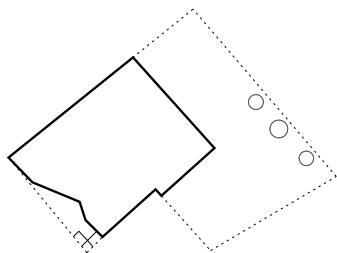

#484

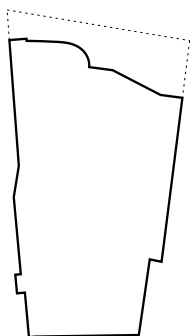
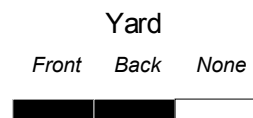
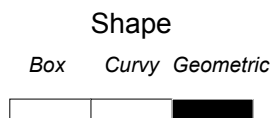
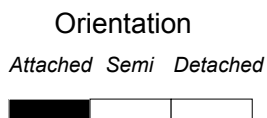

#499

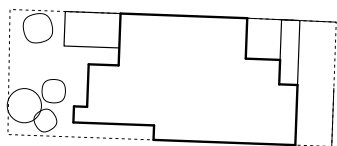
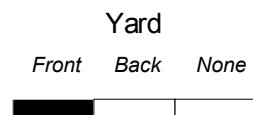
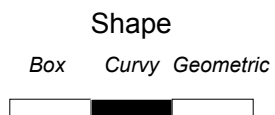
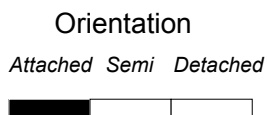

#047

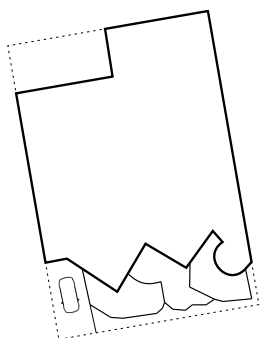
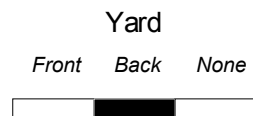
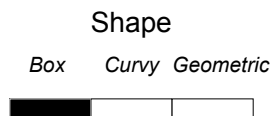
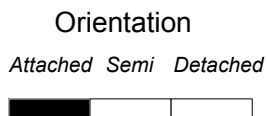

#492

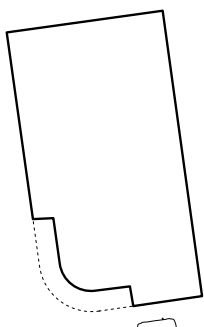
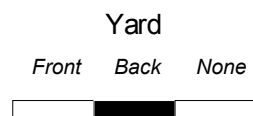
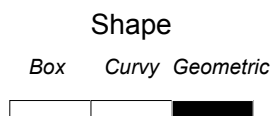
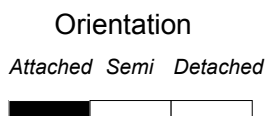

#190

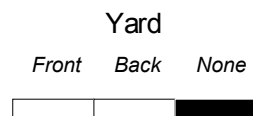
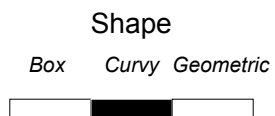
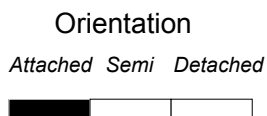

Site Plan

Borders

Fence Wall None



Parking

Drive Street None



Stairs

Yes No

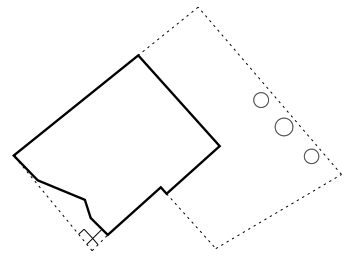

#484

Borders

Fence Wall None

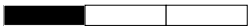

Parking

Drive Street None

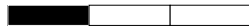

Stairs

Yes No

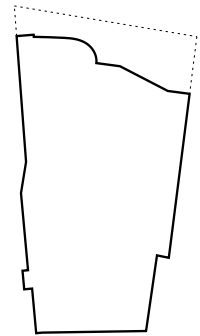

#499

Borders

Fence Wall None



Parking

Drive Street None

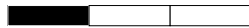

Stairs

Yes No

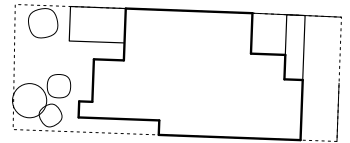

#047

Borders

Fence Wall None



Parking

Drive Street None



Stairs

Yes No

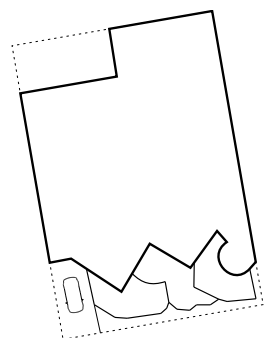

#492

Borders

Fence Wall None



Parking

Drive Street None



Stairs

Yes No

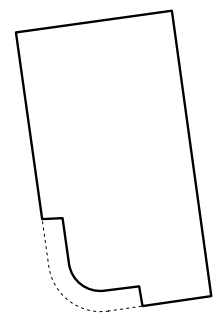

#190

Exterior Materials

Kayleen O'Brien, Lindsey Dierig

Exterior Building Materials

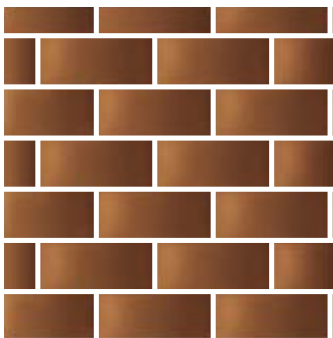

funky town



blue despair



drinking alone

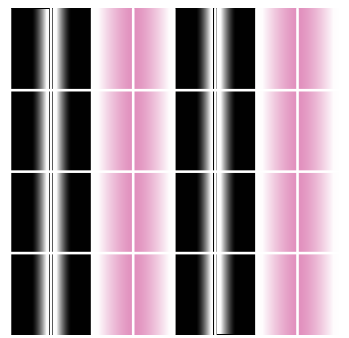

sassy grandma

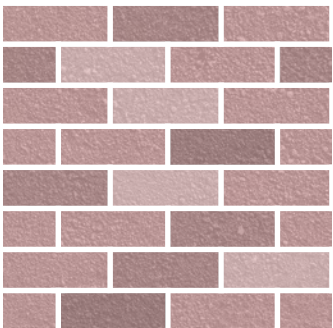

juicy secret

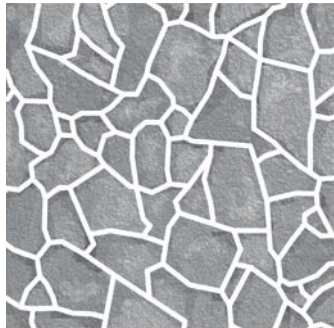

just stone

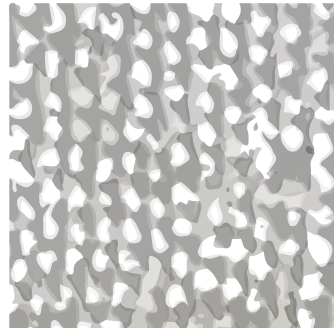

oh! barnacle

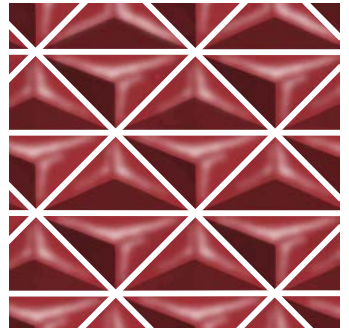

sexy devil

Exterior Building Materials

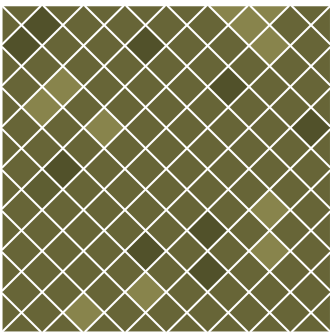

canned pesto

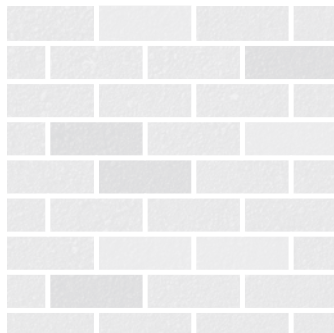

modern ex-pat



daddy money

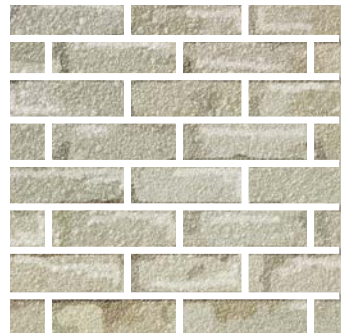

coupon book



shameless

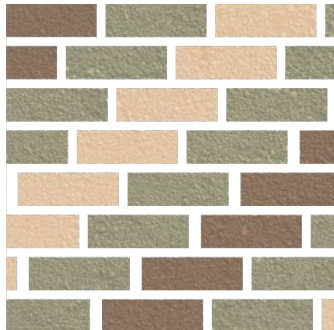

bold and brash

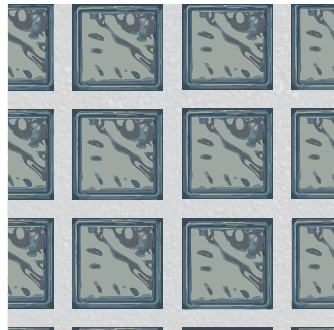

house arrest

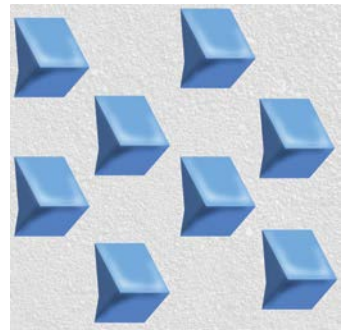

shipwrecked

Exterior Building Materials

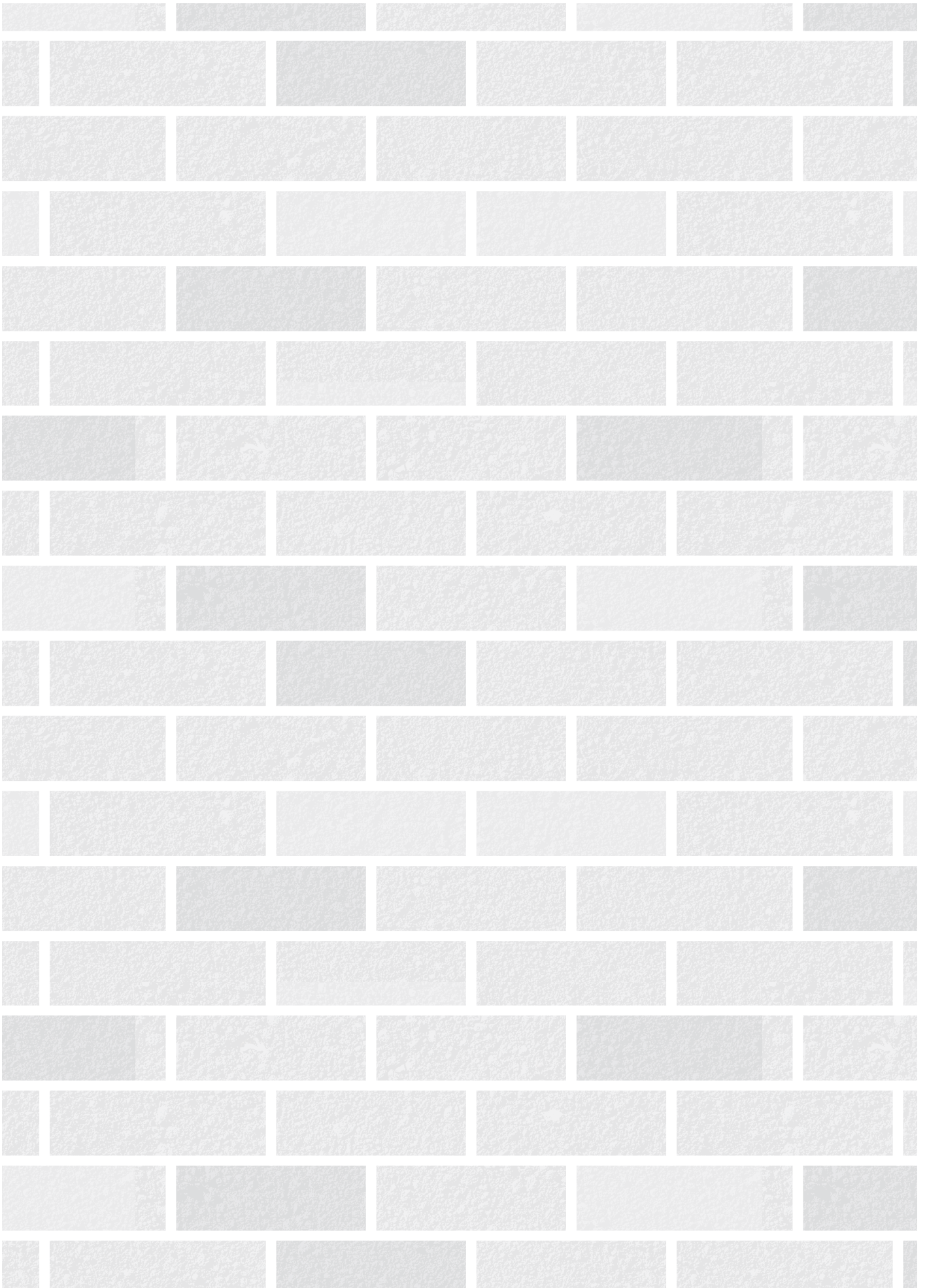

modern ex-pat

Exterior Building Materials

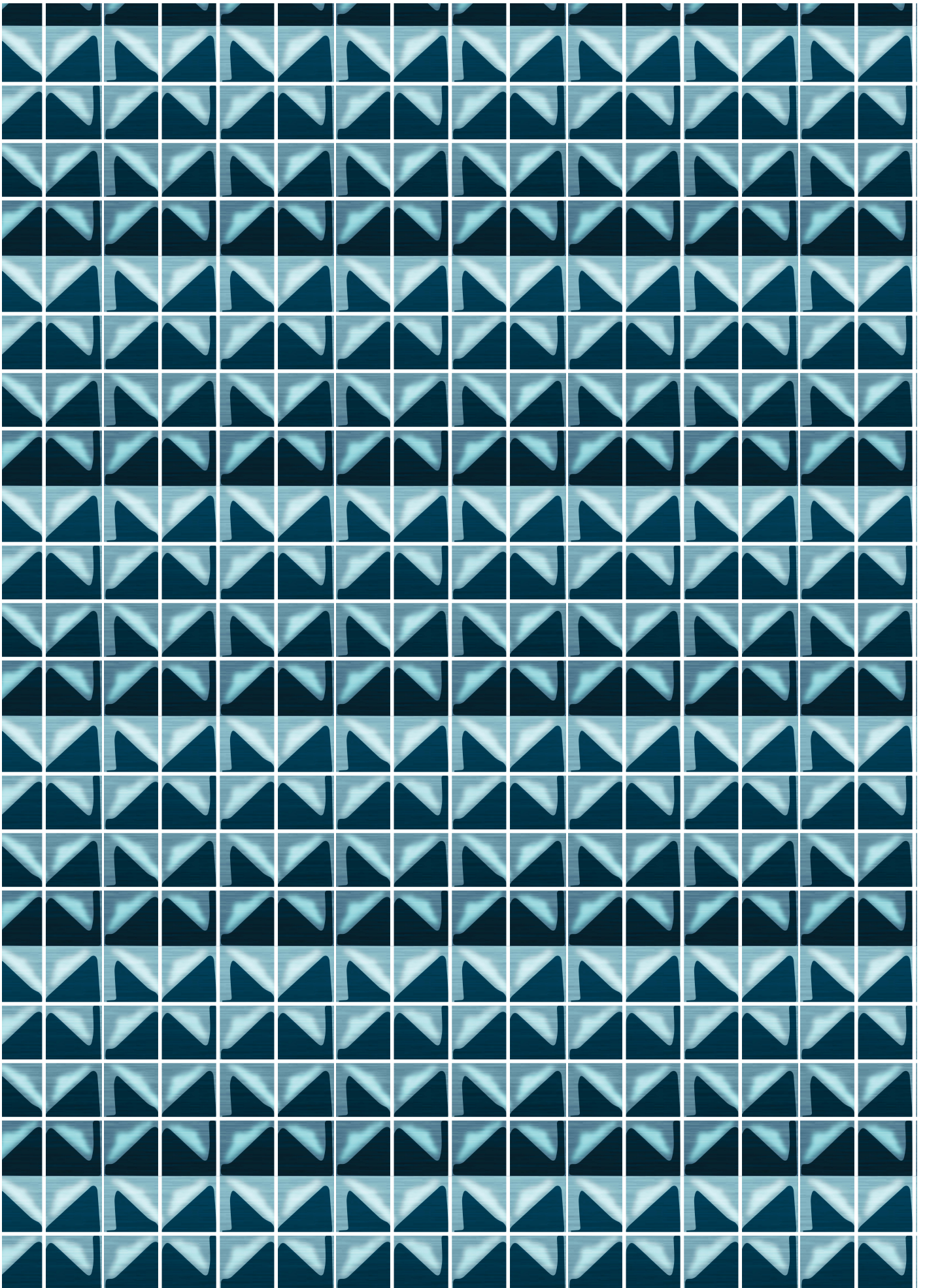

blue despair

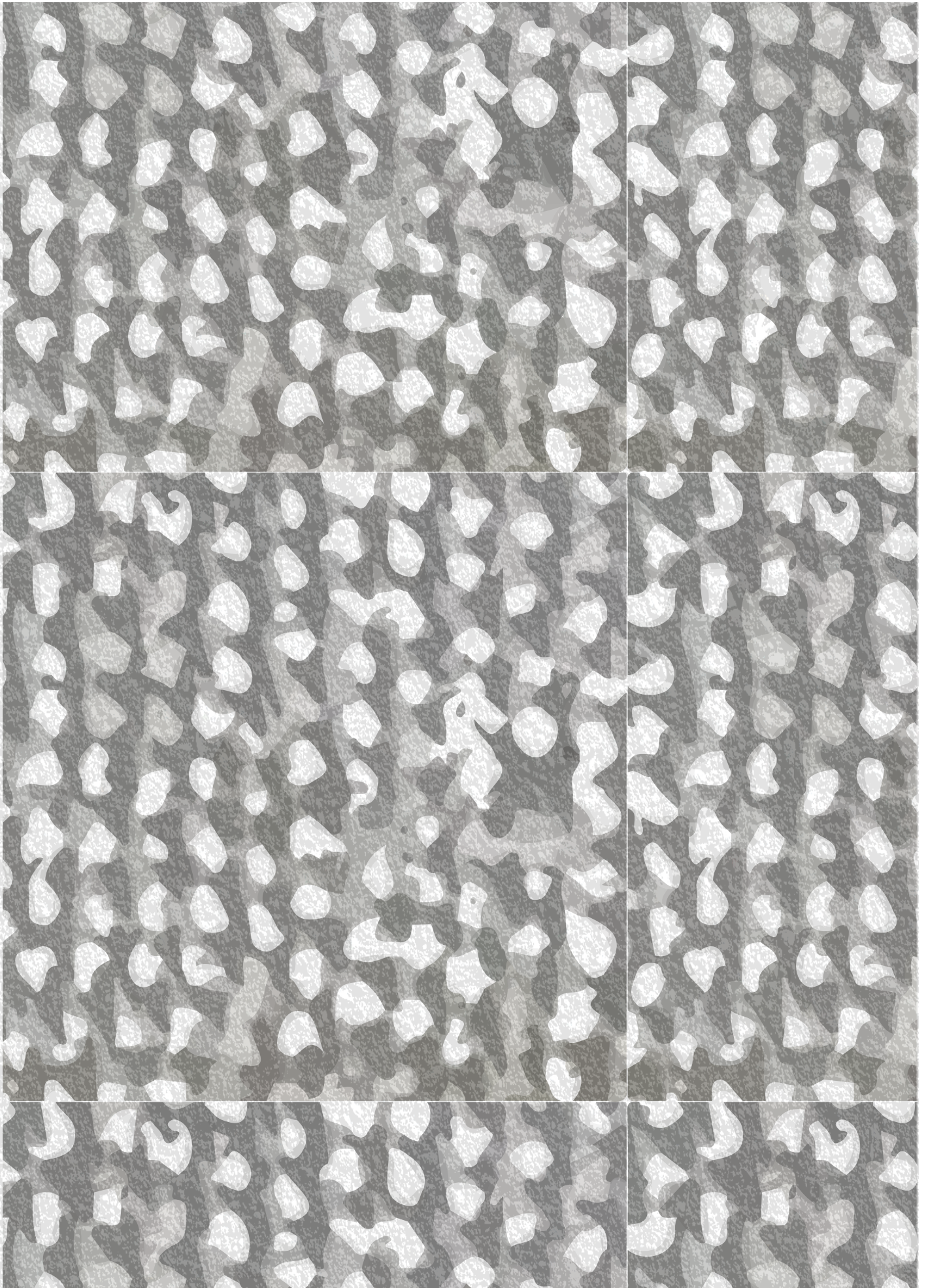

oh! barnacle

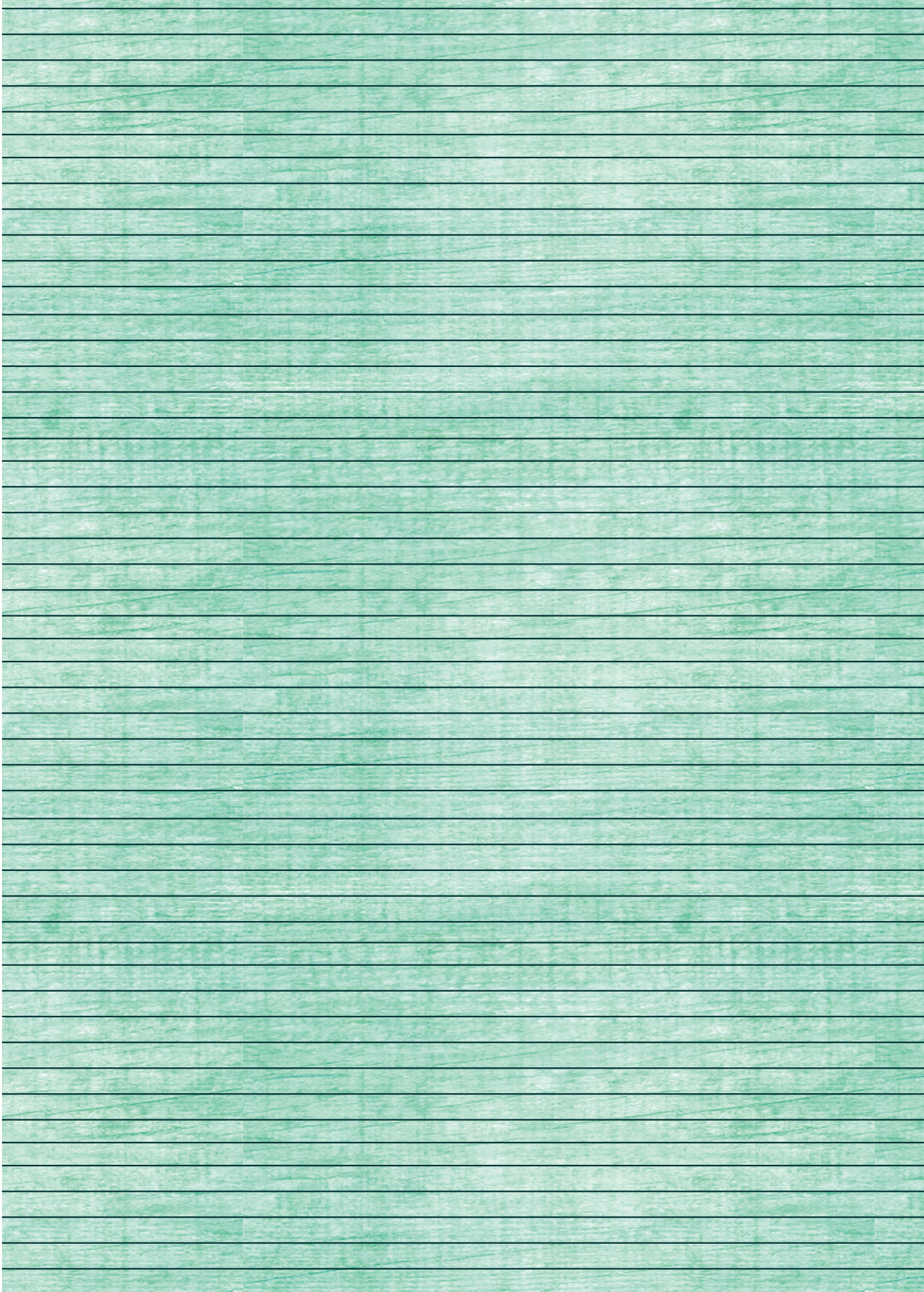

shameless

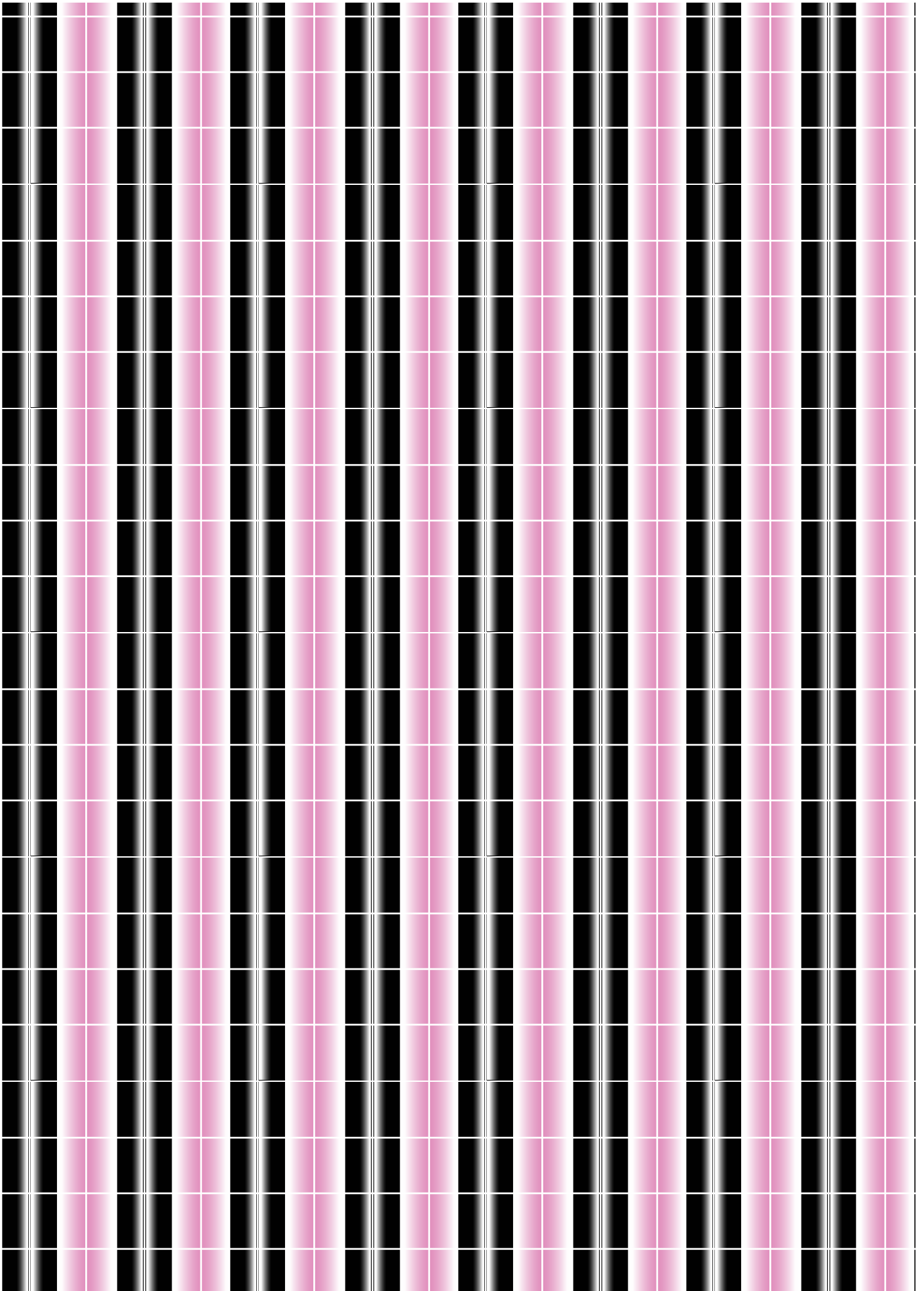

sassy grandma

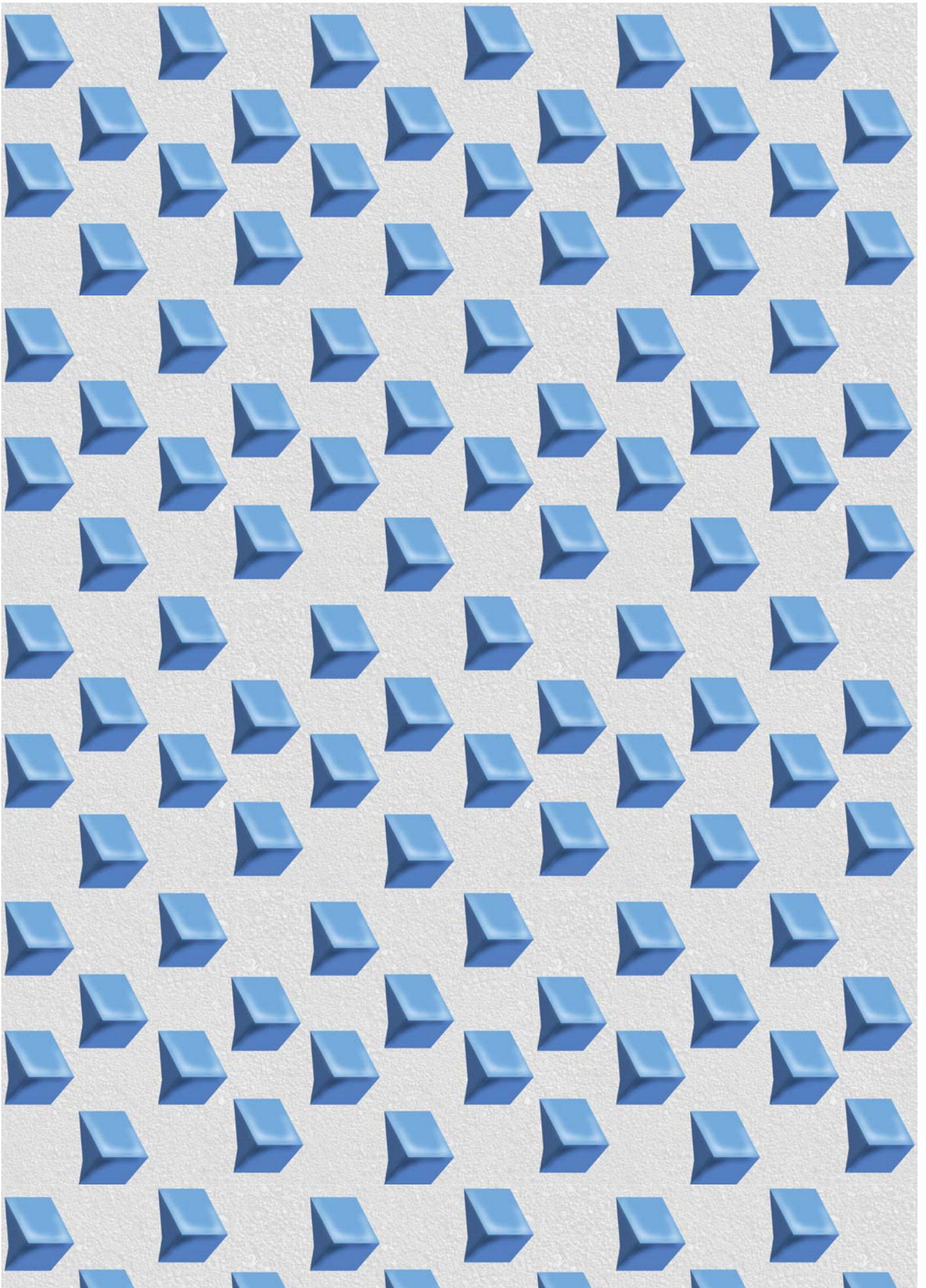

shipwrecked

Exterior Building Materials



december tan
[202,139,62]

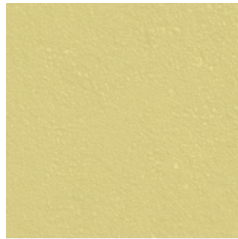

frictionally unemployed
[230,217,141]

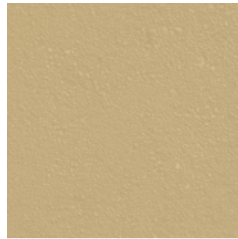

wet blanket
[208,183,133]



personality deficit
[246,232,128]

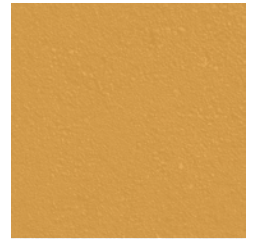

stay at home dad
[224,163,75]

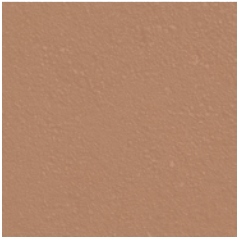

true love
[188,140,108]

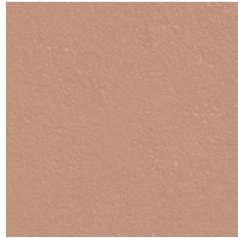

fried shrimp
[206,156,134]

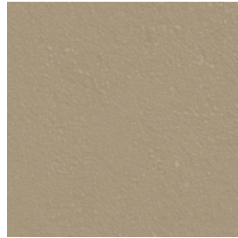

dryer sheet
[177,159,130]

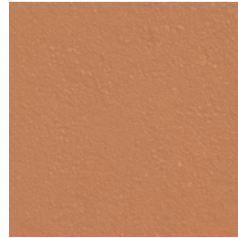

just peachy
[203,134,92]

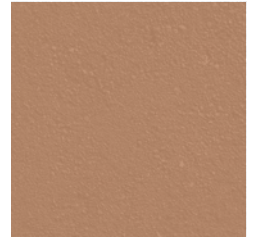

high nooner
[187,138,106]

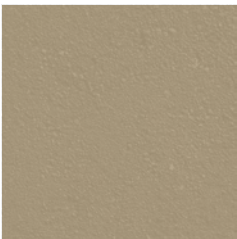

cigarette box
[174,157,127]

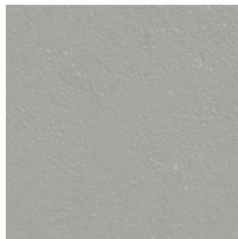

spilled milk
[176,176,170]

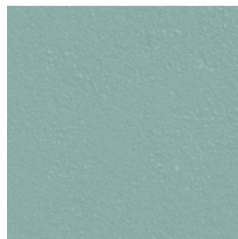

shower shoes
[147,183,179]

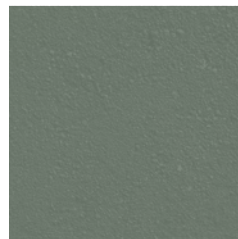

good listener
[112,125,112]



space club
[160,174,157]

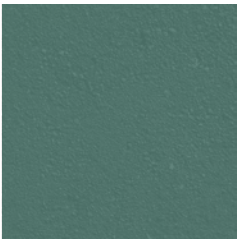

poseidon's hot tub
[81,119,111]

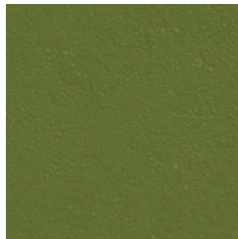

the green mile
[100,114,48]



dead ex-husband
[190,63,29]

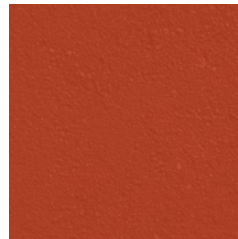

recycled bacardi
[182,62,34]

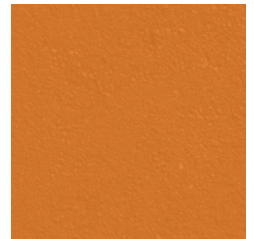

morning spritz
[222,121,40]



daddy's secret
[221,33,39]

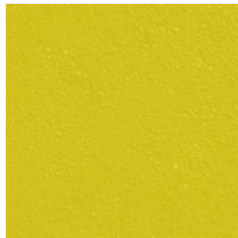

margarita mondays
[223,205,24]

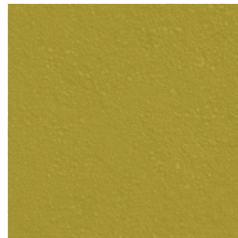

daddy issues
[175,156,50]

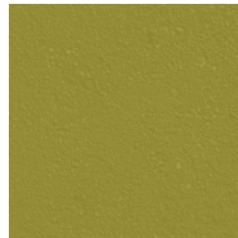

tacky flip flops
[156,148,32]



kale salad
[255,248,212]



fire escape
[230,123,92]

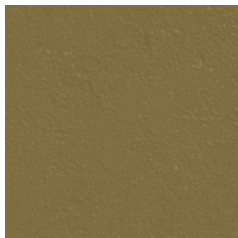

olive pit
[133,114,65]

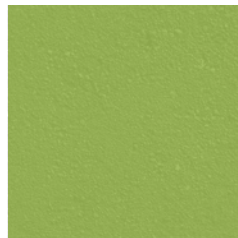

file not found
[154,184,84]

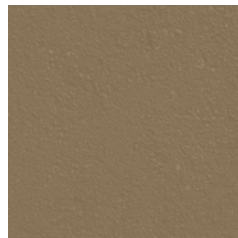

nuclear family
[142,190,20]



out-of-wedlock baby
[173,152,110]



coconut rum
[236,179,117]

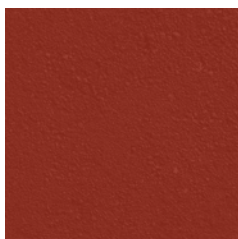

hidden talents
[145,40,0]

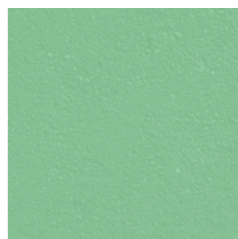

loose change
[139,204,155]



walking on sunshine
[142,255,255]



writer's block
[255,254,250]

Exterior Building Materials

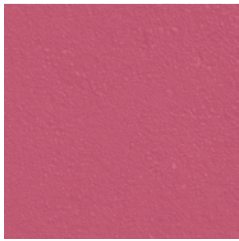

shotgun wedding
[205,91,119]

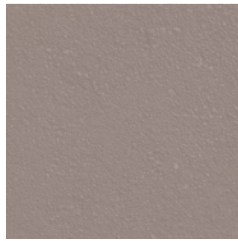

seductive bedsheets
[160,143,137]

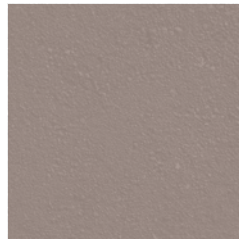

white collar mistress
[160,143,136]



crazy cat lady
[135,115,120]

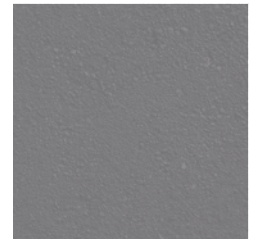

spunky craft room
[130,128,132]

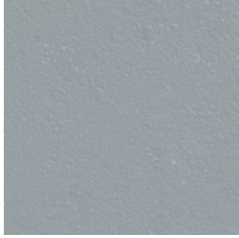

white walker
[159,170,175]

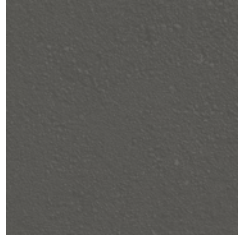

side hustle
[90,89,85]

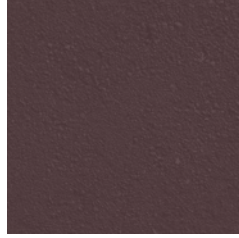

work the corner
[82,59,63]

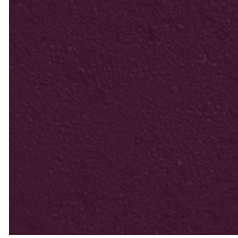

tax evasion
[61,18,44]

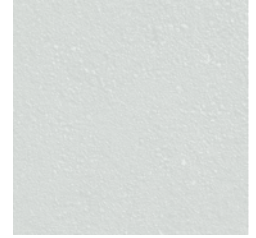

daycare chic
[229,234,231]



part-time nihilist
[149,144,125]

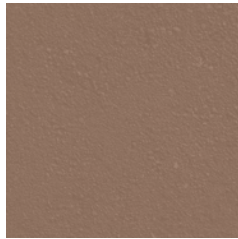

microfiber couch
[149,117,98]

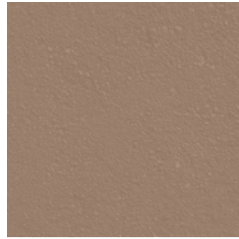

generic groceries
[162,133,111]



moody mom
[67,37,31]



fallen gelato
[108,70,52]



bottom shelf merlot
[114,69,67]

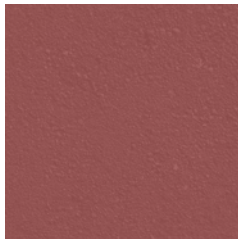

hot for my age
[155,84,83]

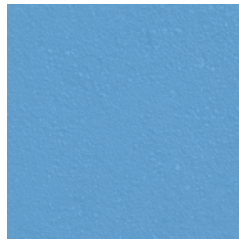

cheap motel
[101,167,219]

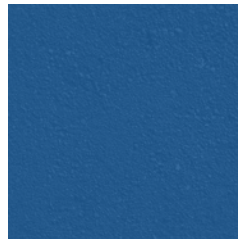

little league allstar
[31,89,146]



steel toe boots
[99,167,165]

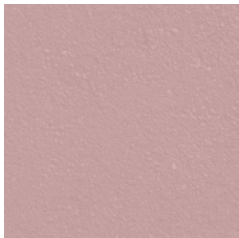

the virgin larry
[208,169,170]

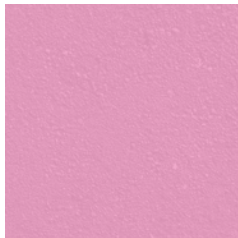

budget seafood
[244,161,198]



bedside toy
[224,168,176]

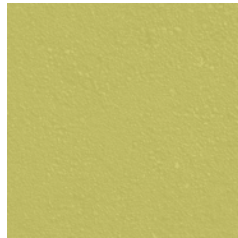

jurassic nark
[203,198,104]



university t-shirt
[136,161,140]



gentrified ghetto
[97,98,100]

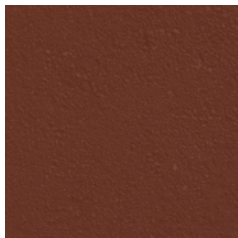

midnight ragu
[106,51,35]



witchcraft dabbler
[134,60,53]

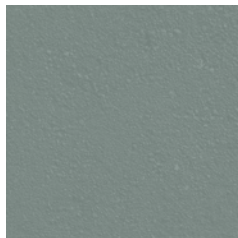

flirty and thirty
[129,144,139]



rubber ducky
[255,255,0]

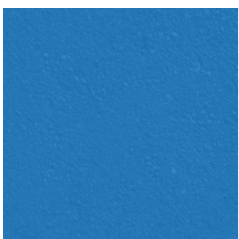

laundry detergent
[27,123,192]

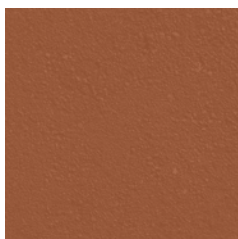

bad intentions
[159,90,57]

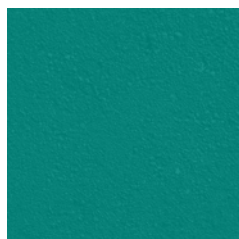

questionable taste
[0,135,125]

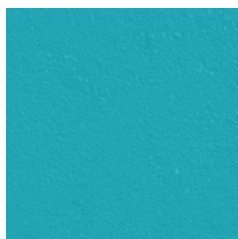

wild ambition
[29,174,192]



up to no good
[255,199,0]

Exterior Building Materials

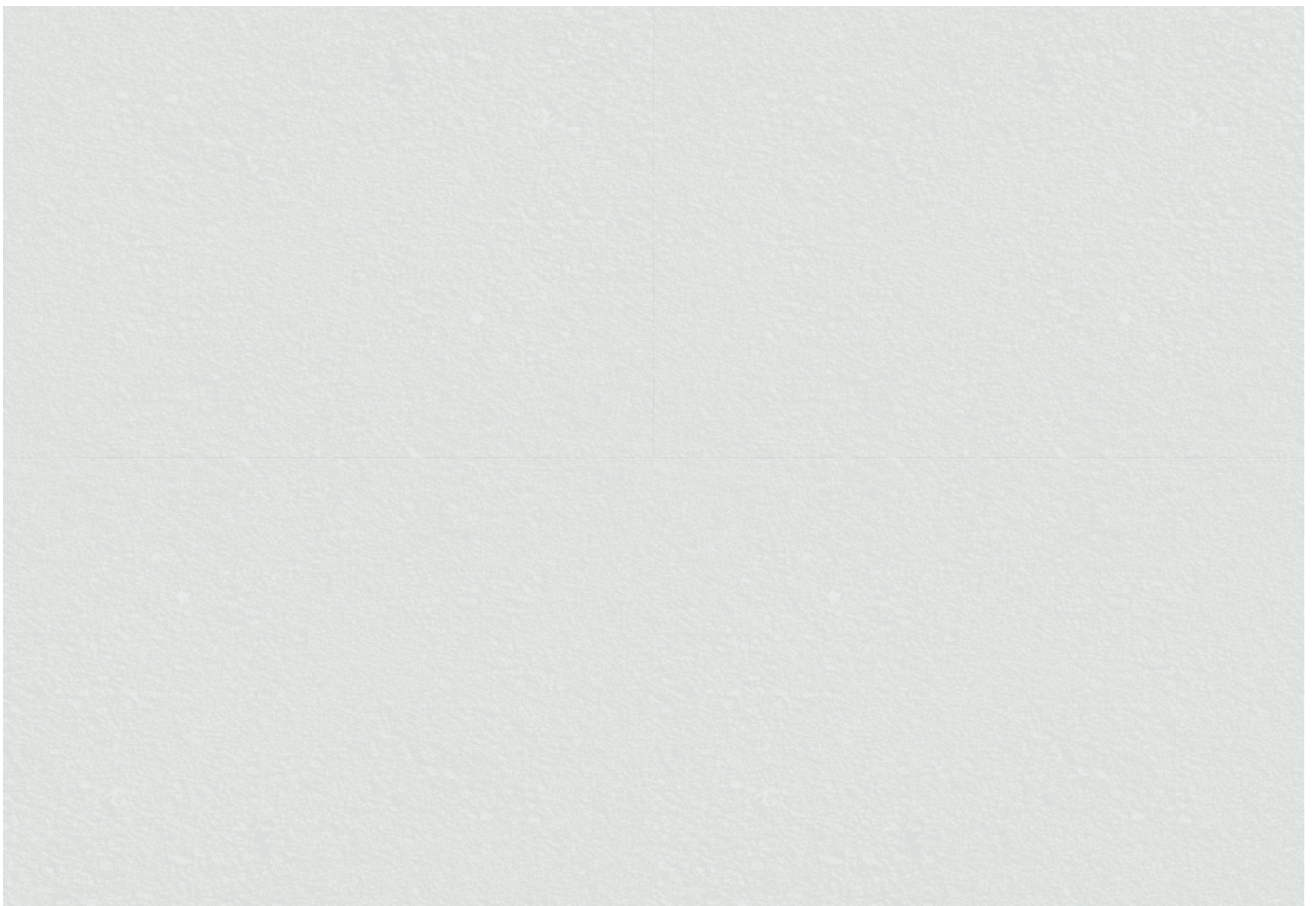
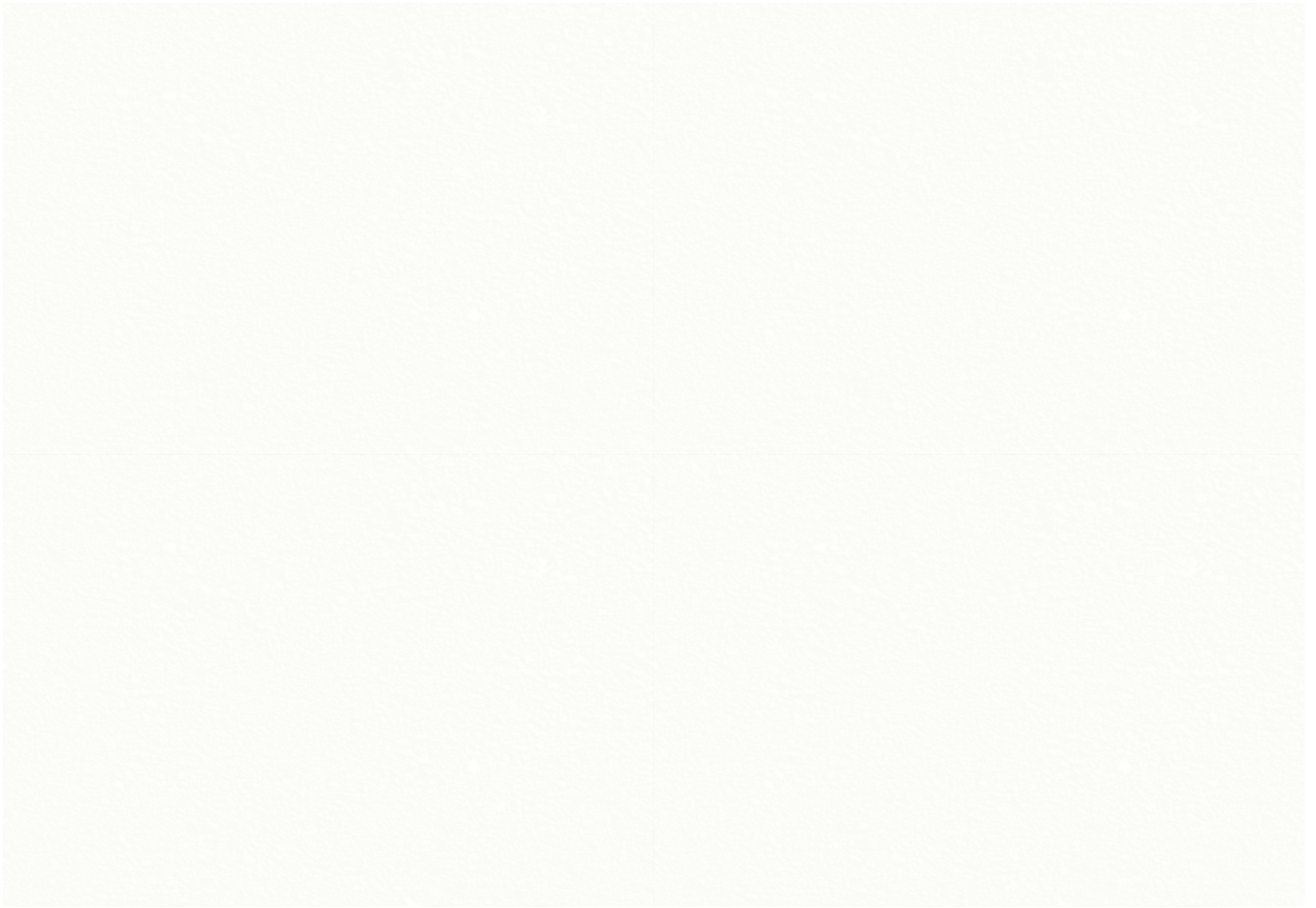

base: writer's block
accent: daycare chic

Exterior Building Materials

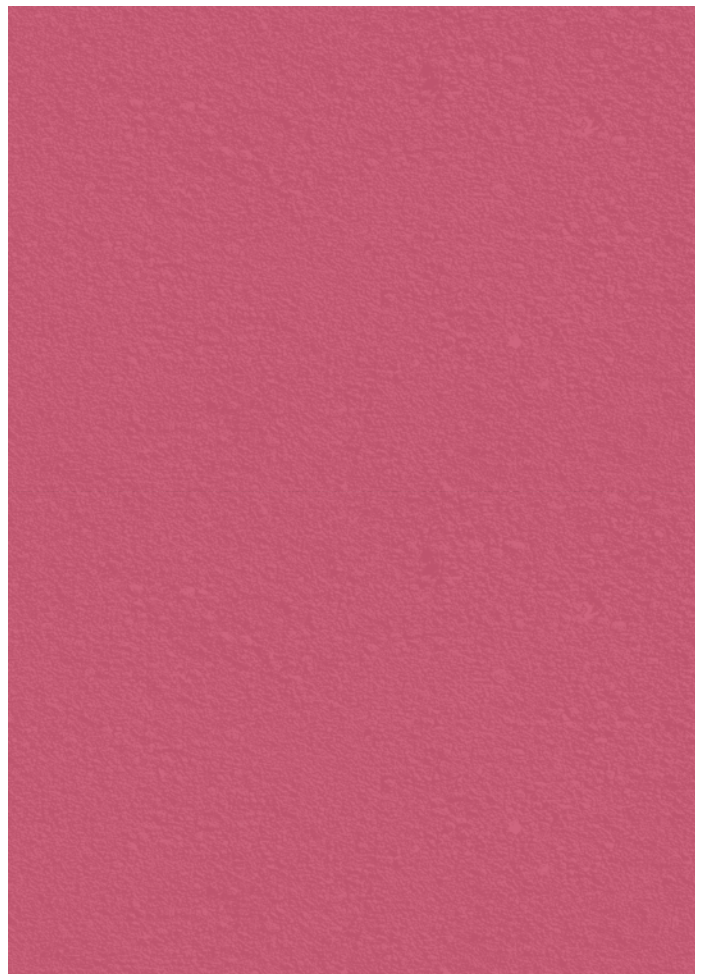

base: budget seafood
accent: spilled milk, shotgun wedding

Exterior Building Materials

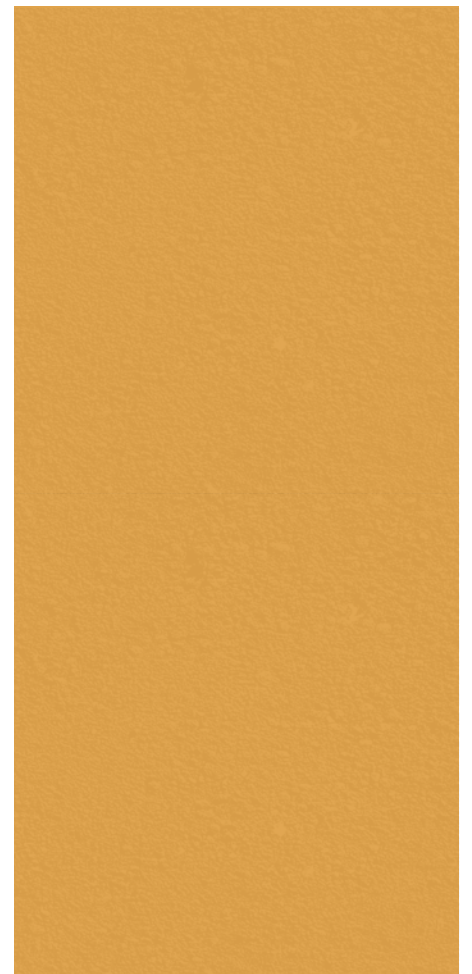
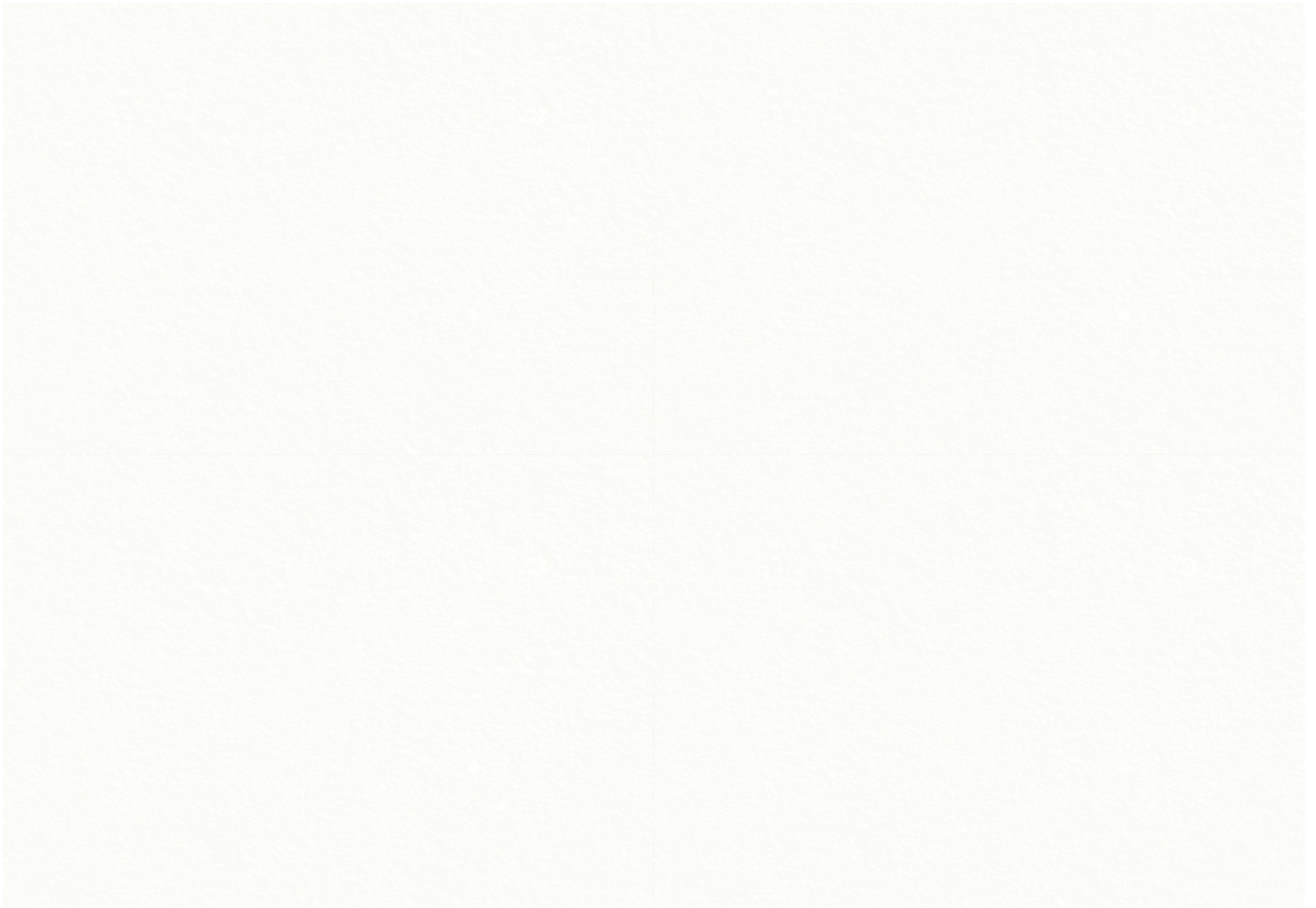

base: writer's block
accent: witchcraft dabbler, questionable taste, stay at home dad

Exterior Building Materials

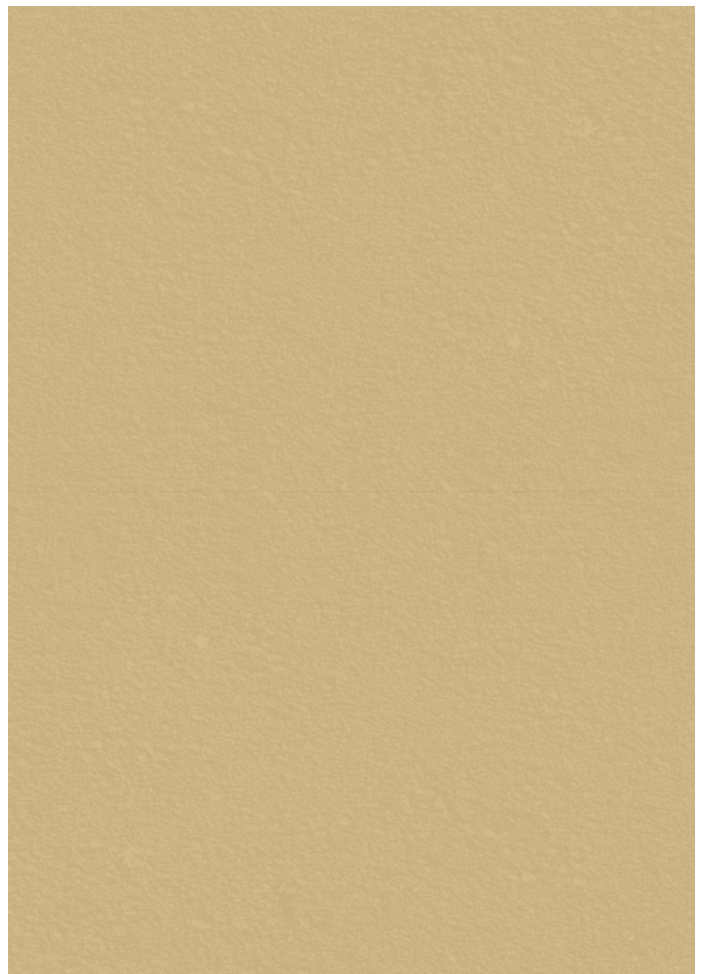
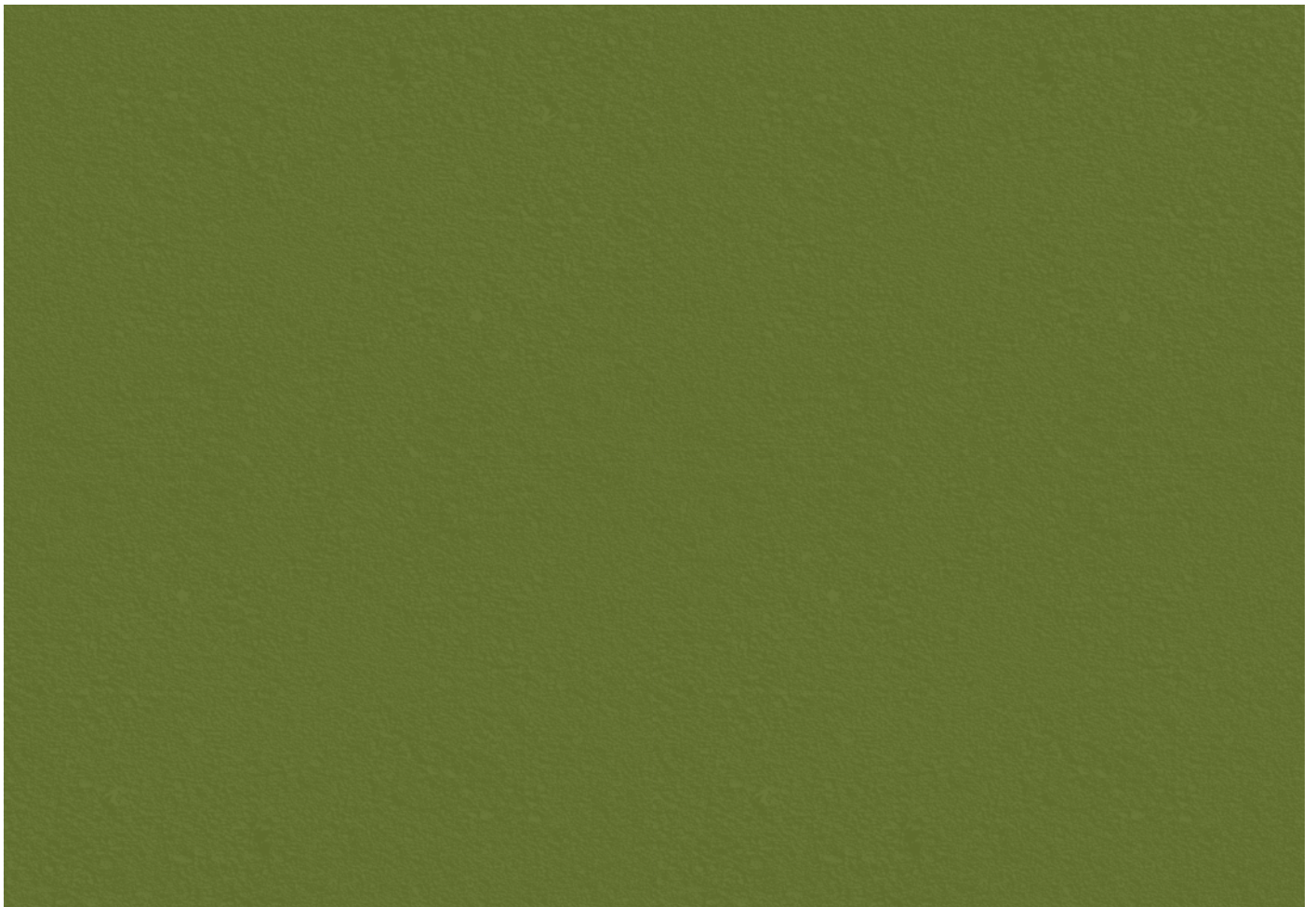

base: the green mile
accent: bad intentions, wet blanket

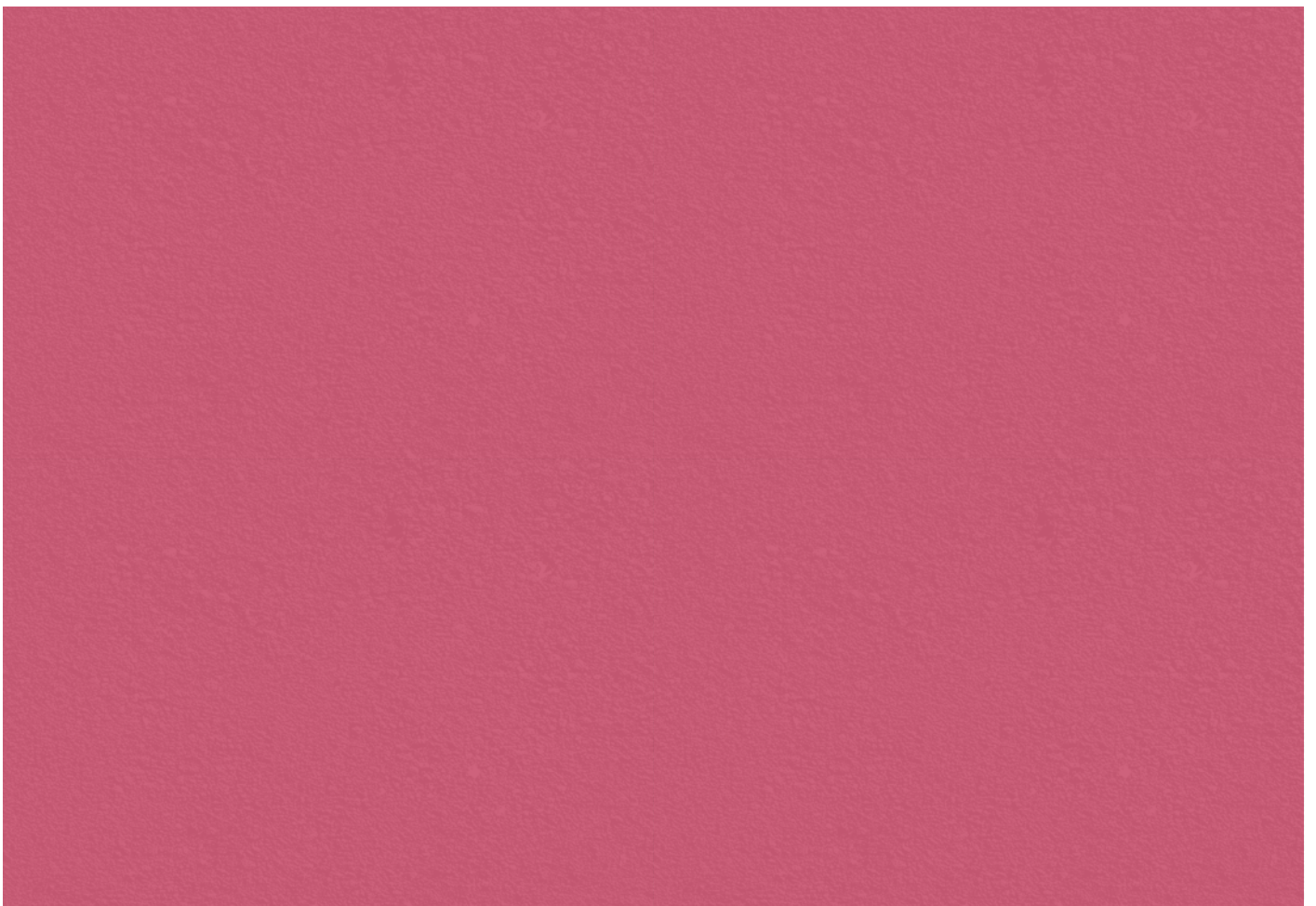
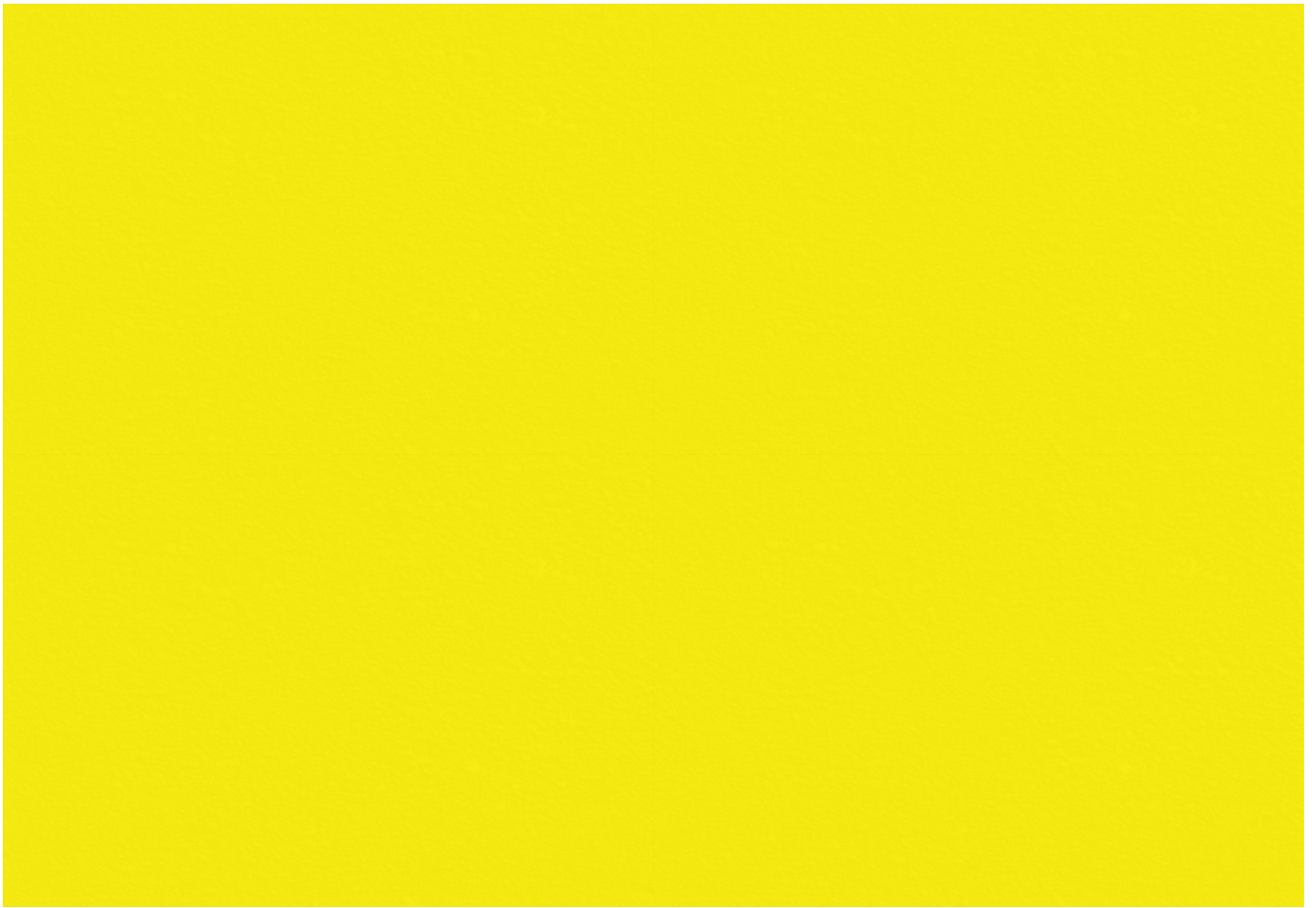

base: rubber ducky
accent: shotgun wedding

Exterior Building Materials

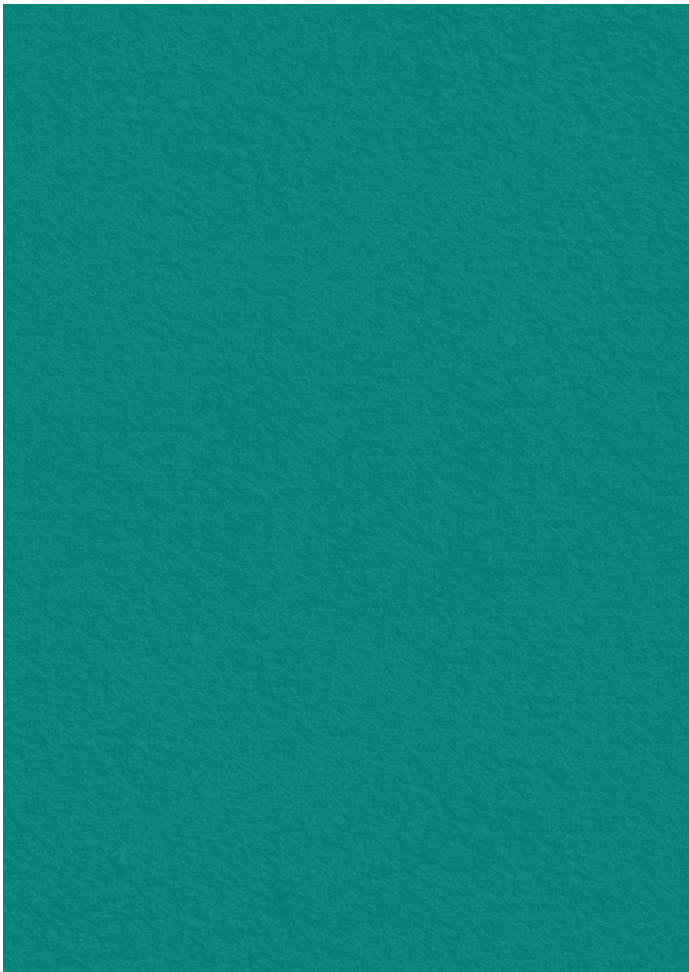
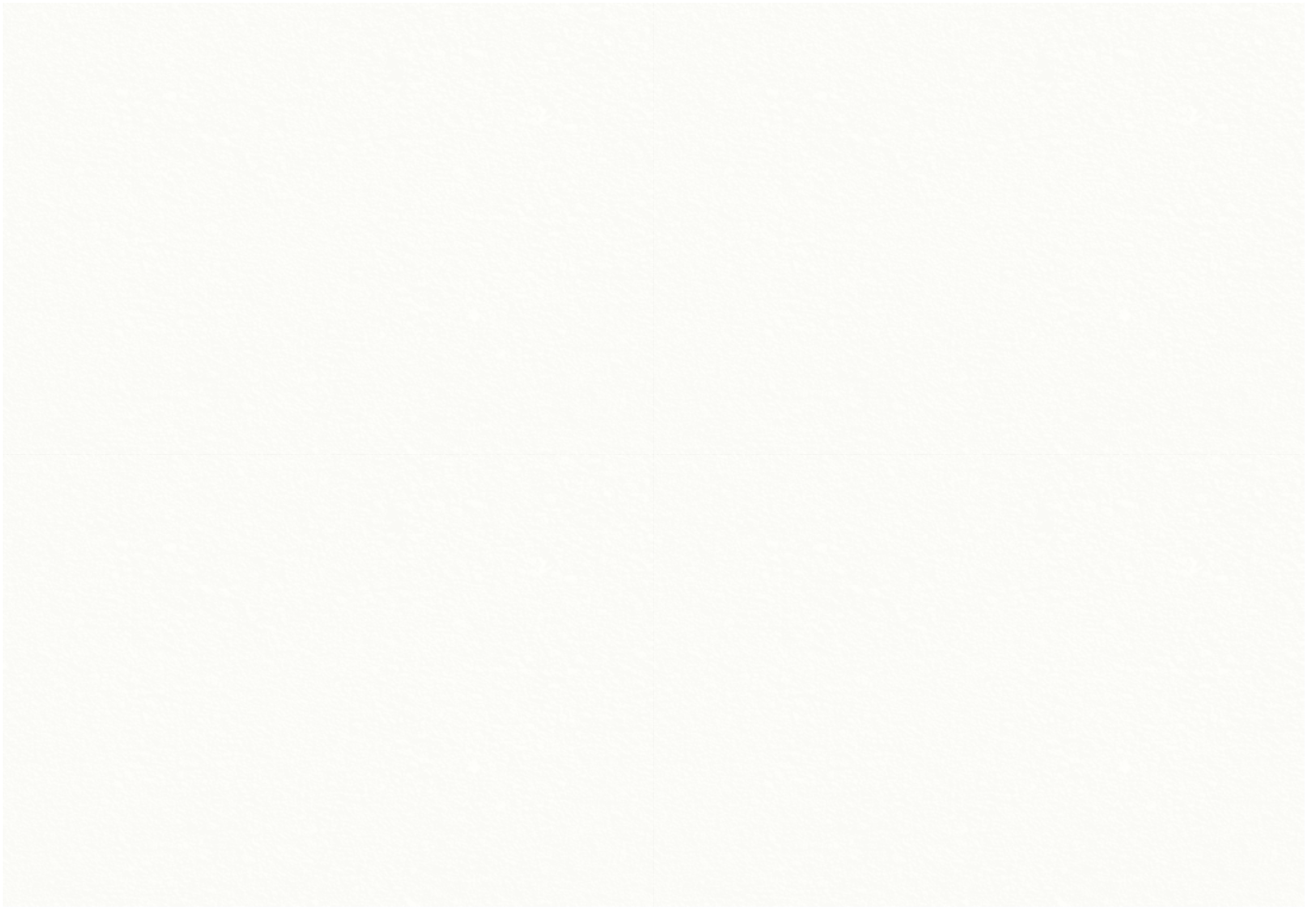

base: writer's block
accent: questionable taste, moody mom

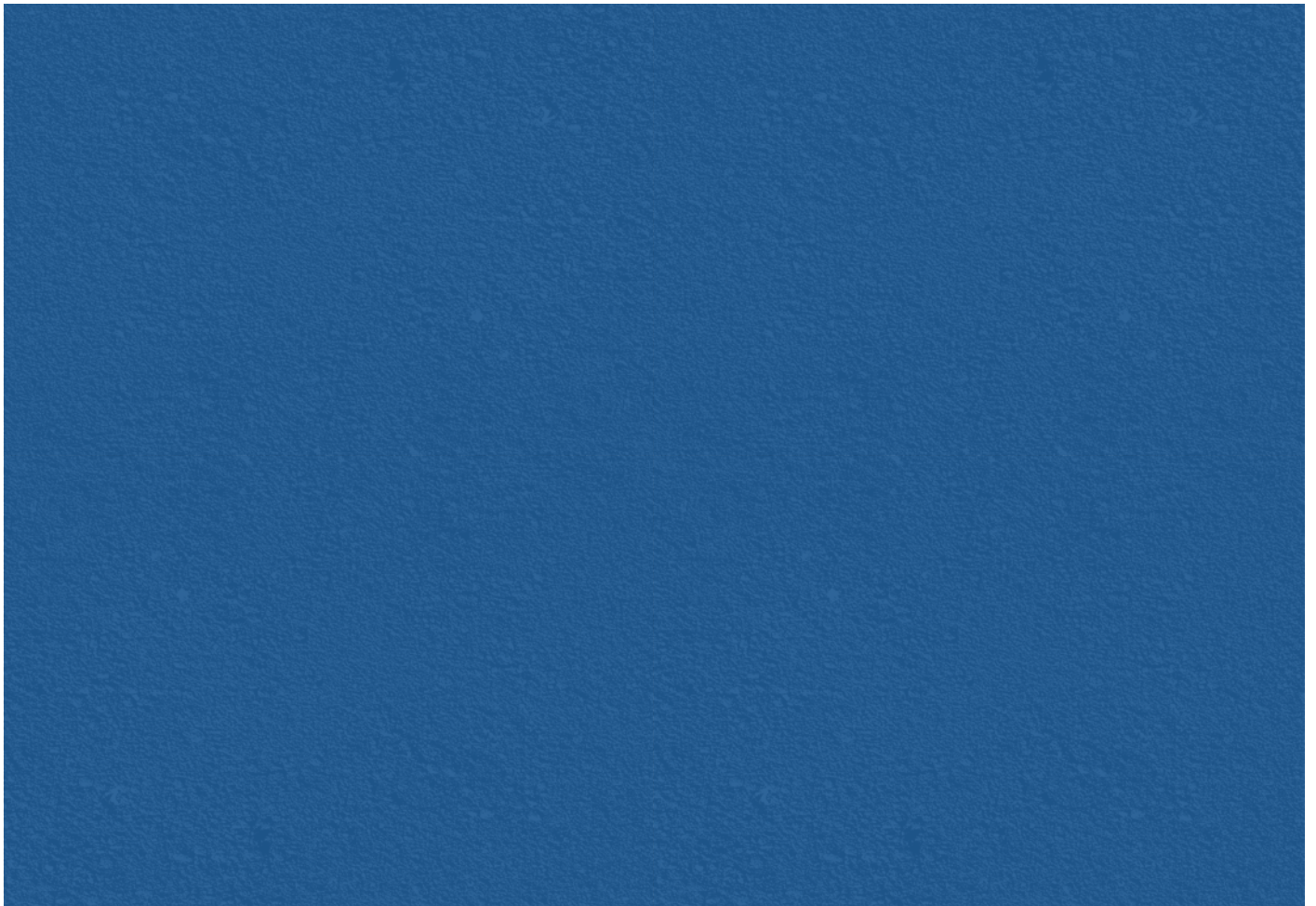
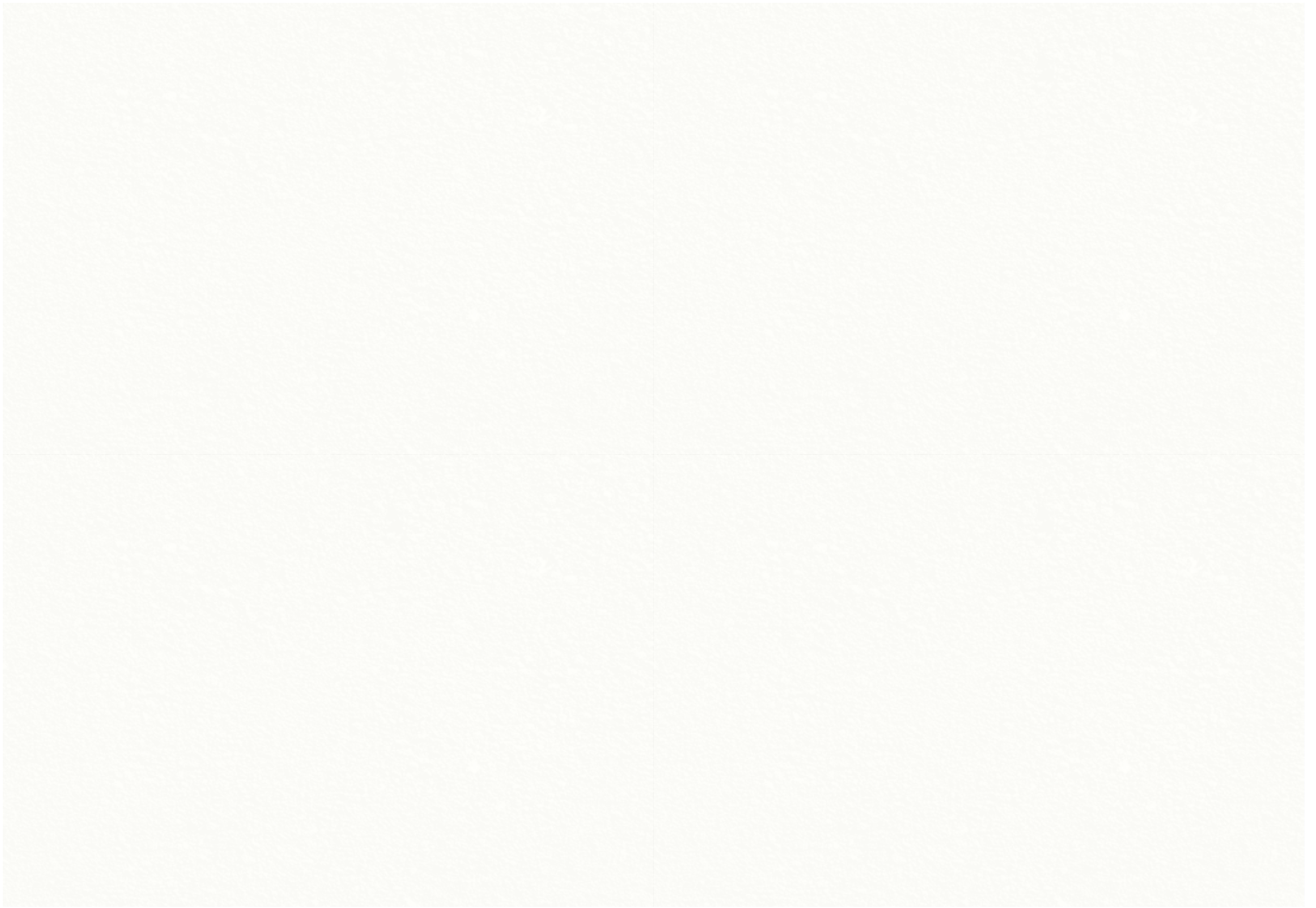

base: writer's block
accent: little league allstar

Exterior Building Materials

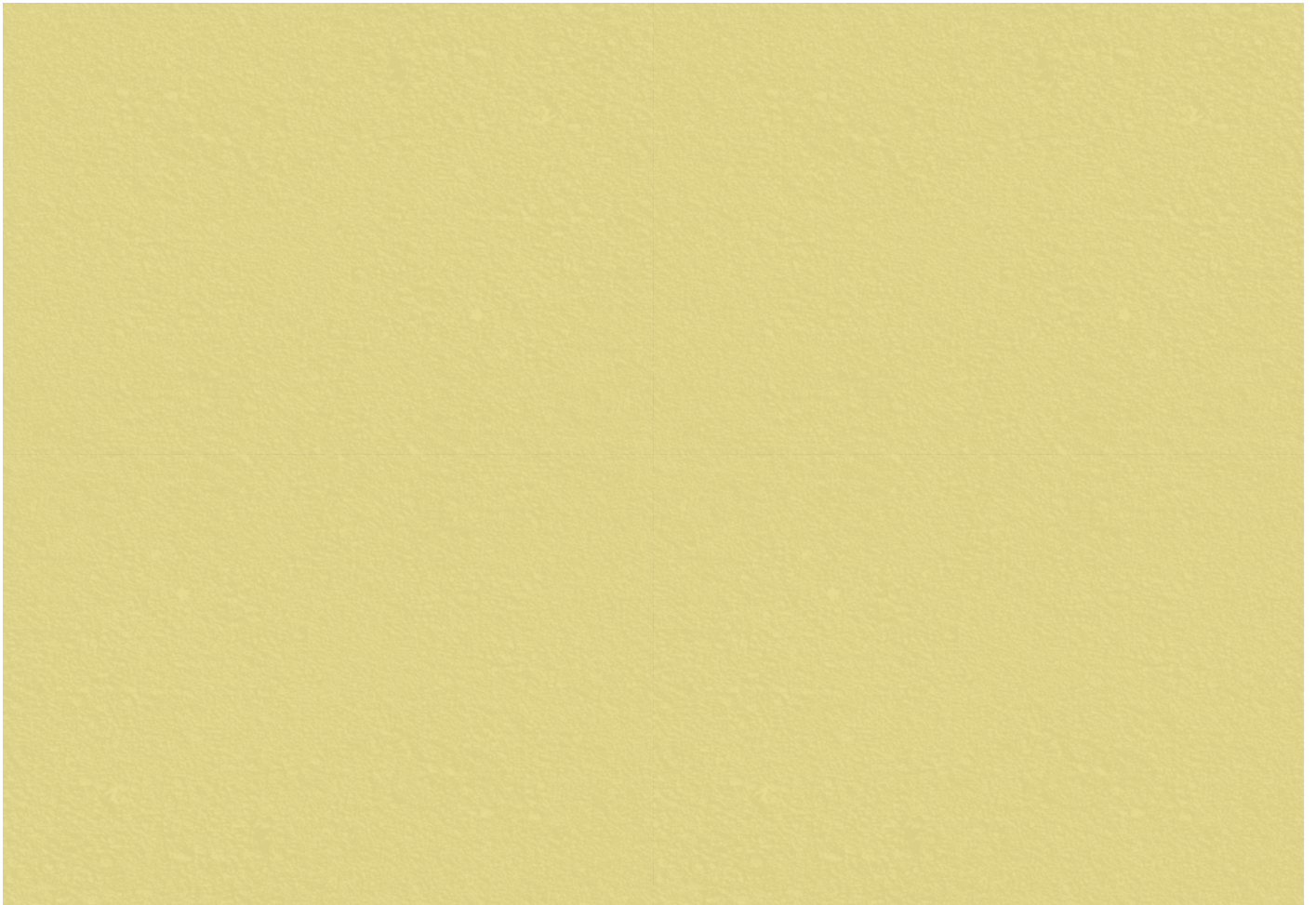

base: frictionally unemployed
accent: writer's block, fallen gelato

Exterior Building Materials

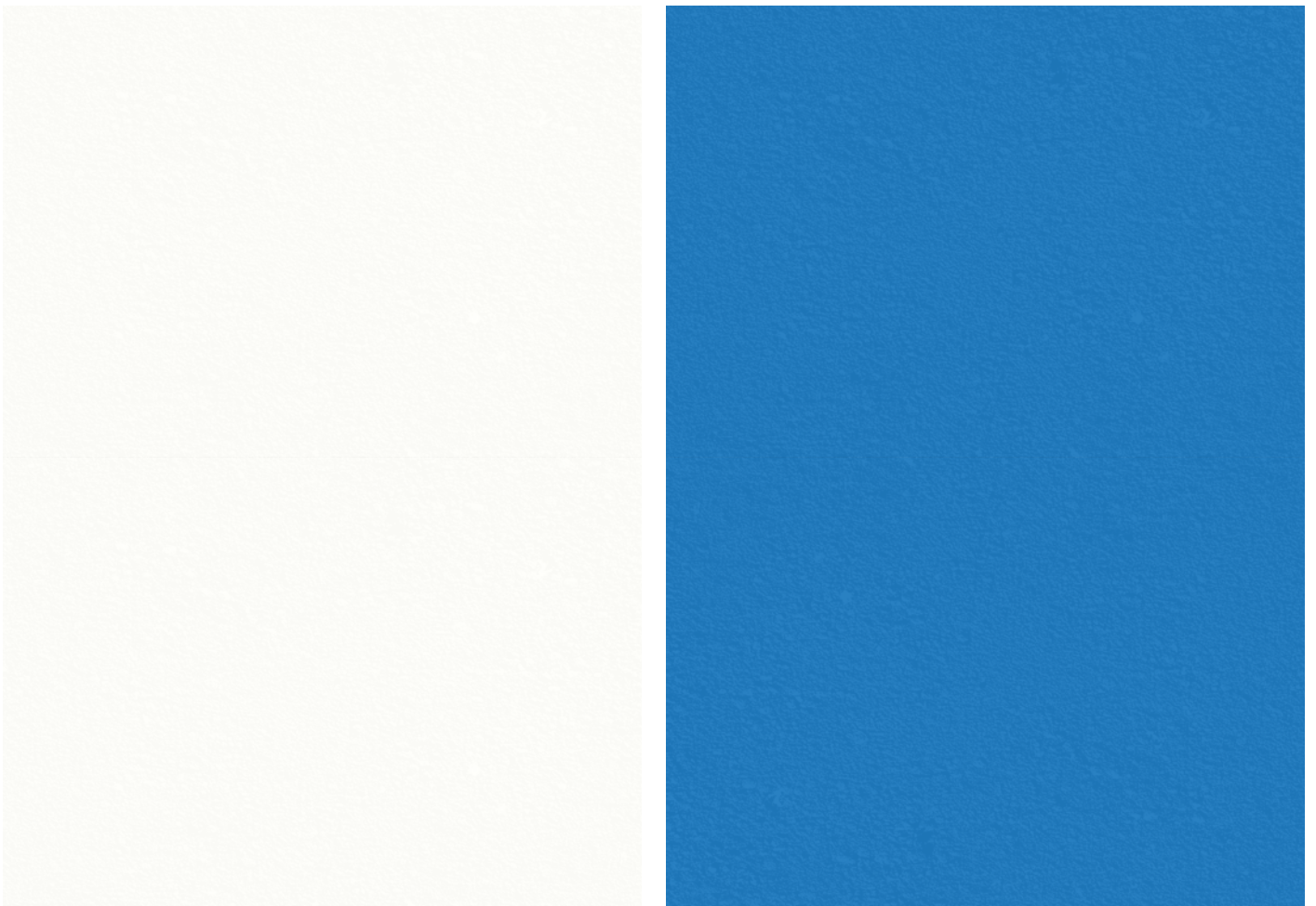

base: kale salad
accent: writer's block, laundry detergent

Exterior Building Materials

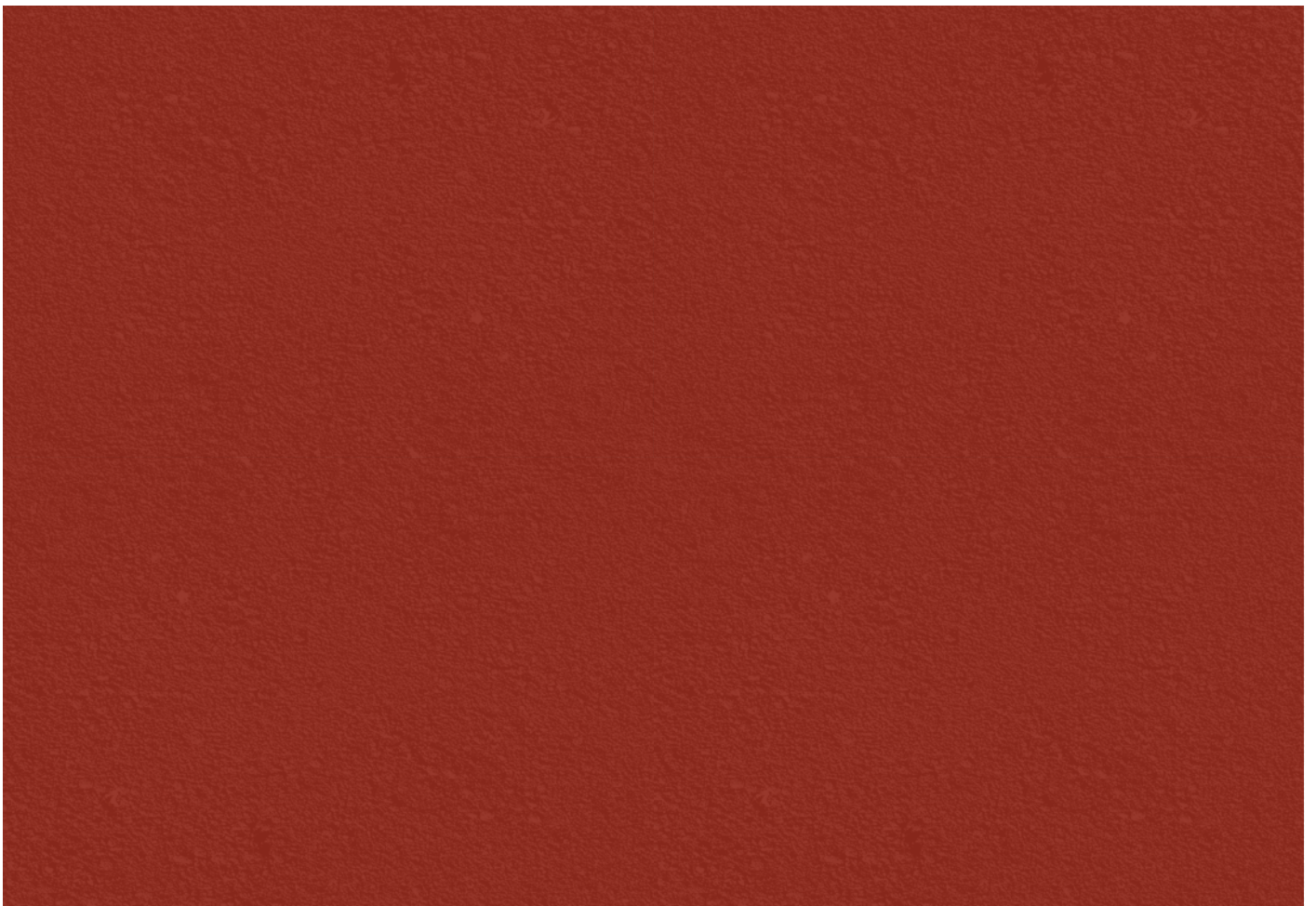
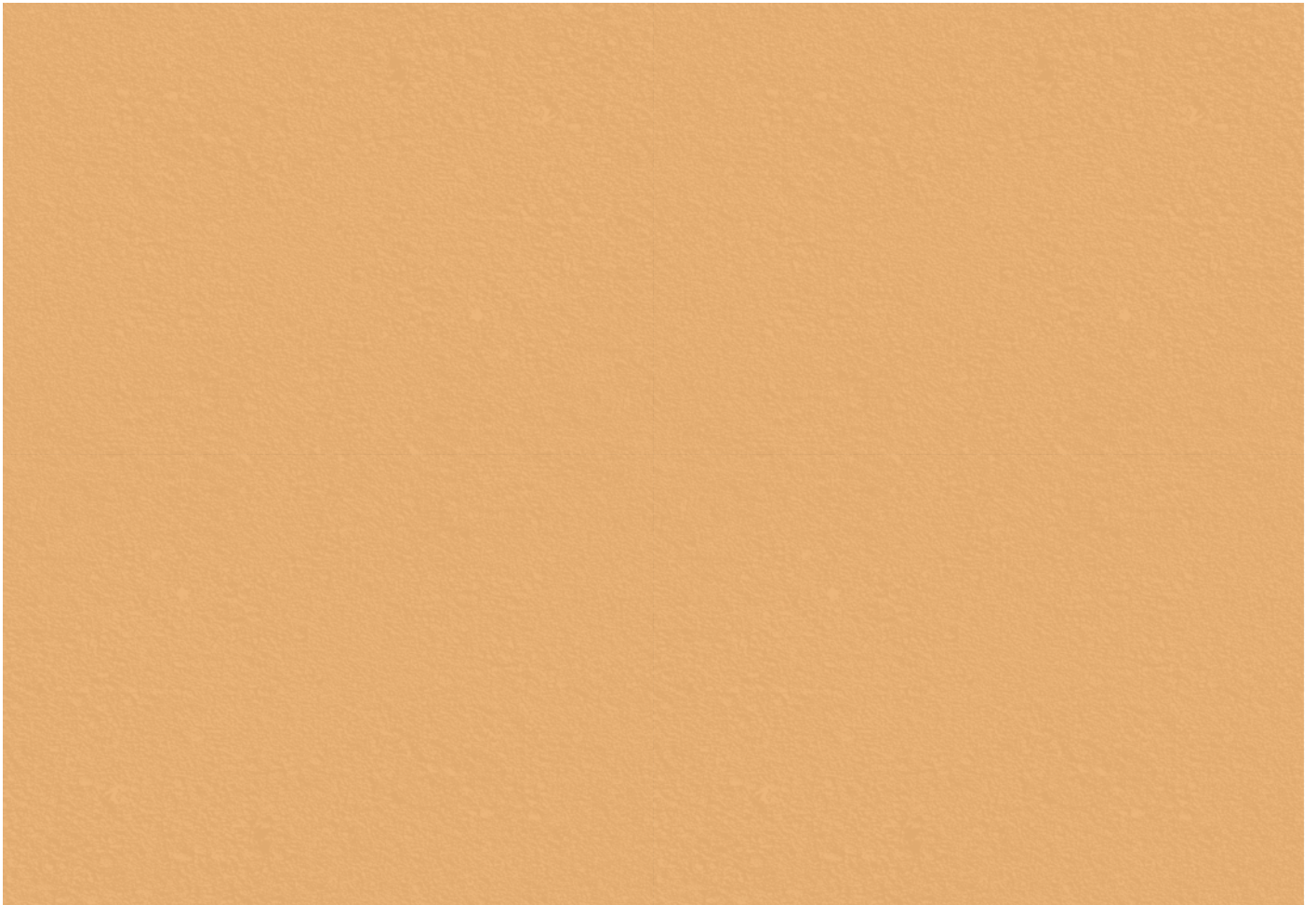

base: coconut rum
accent: hidden talents

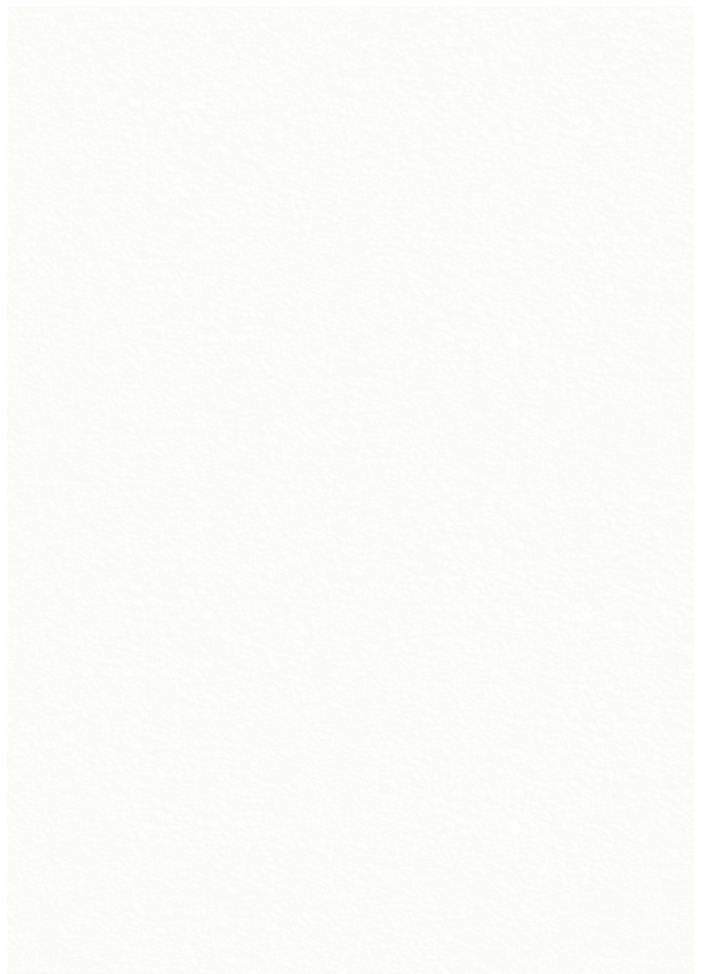

base: questionable taste
accent: up to no good, writer's block

Exterior Building Materials

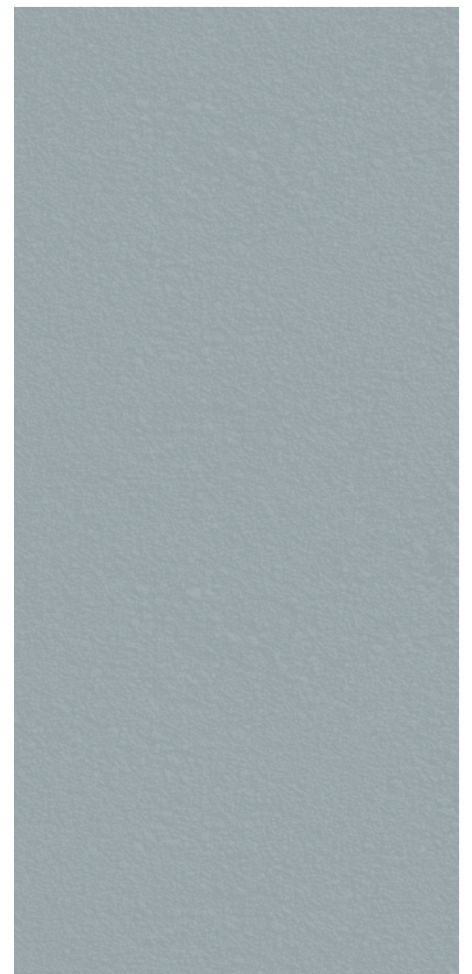
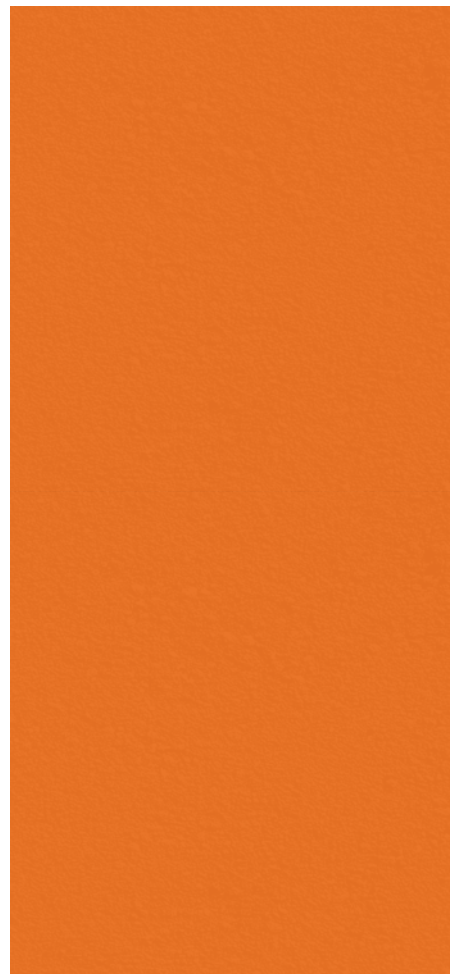
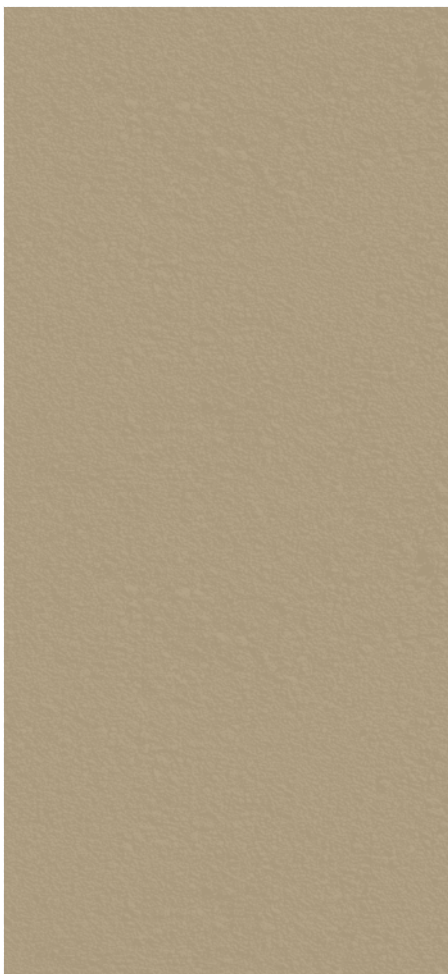
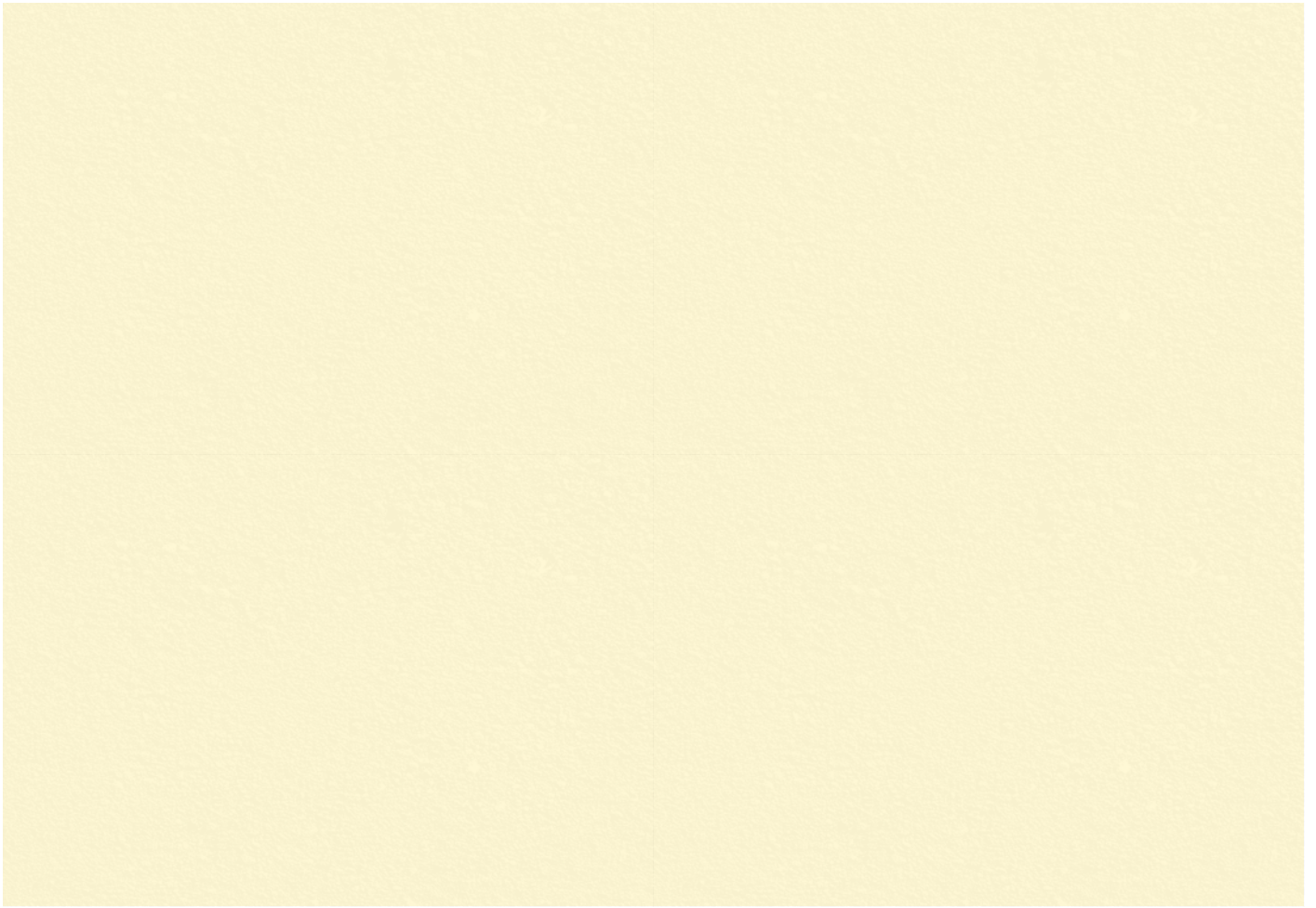

base: kale salad
accent: dryer sheet, morning spritz, white walker

Exterior Building Materials

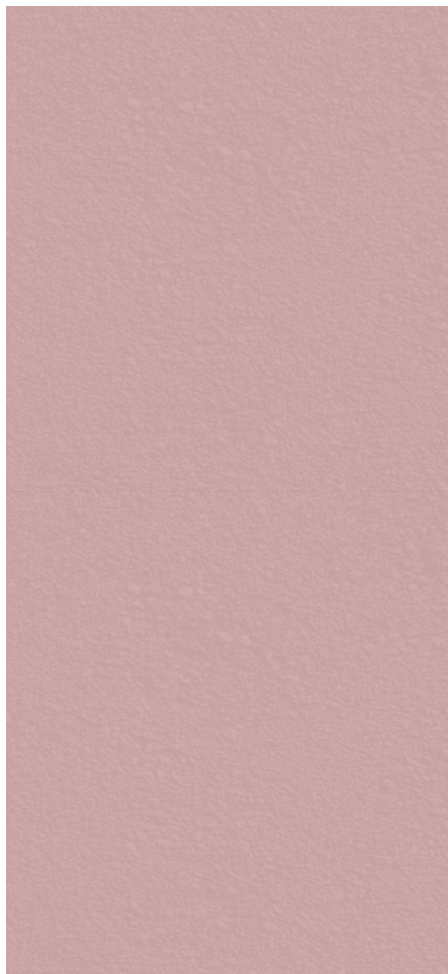
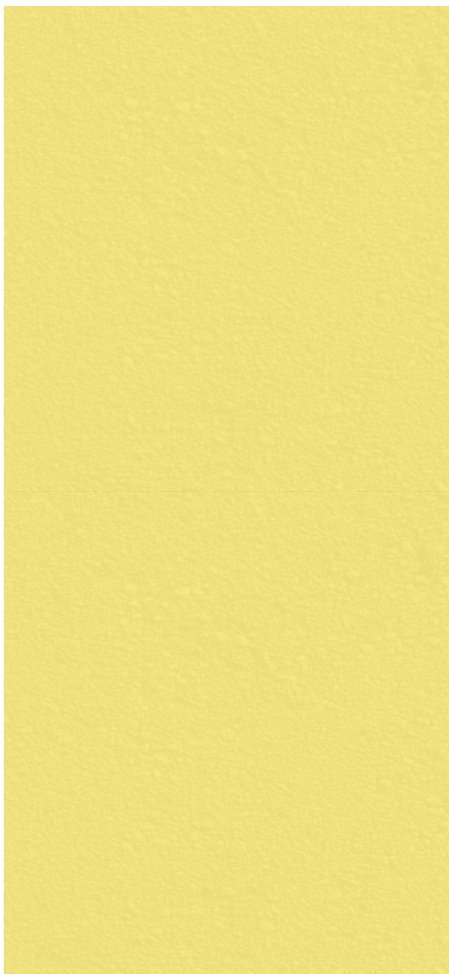
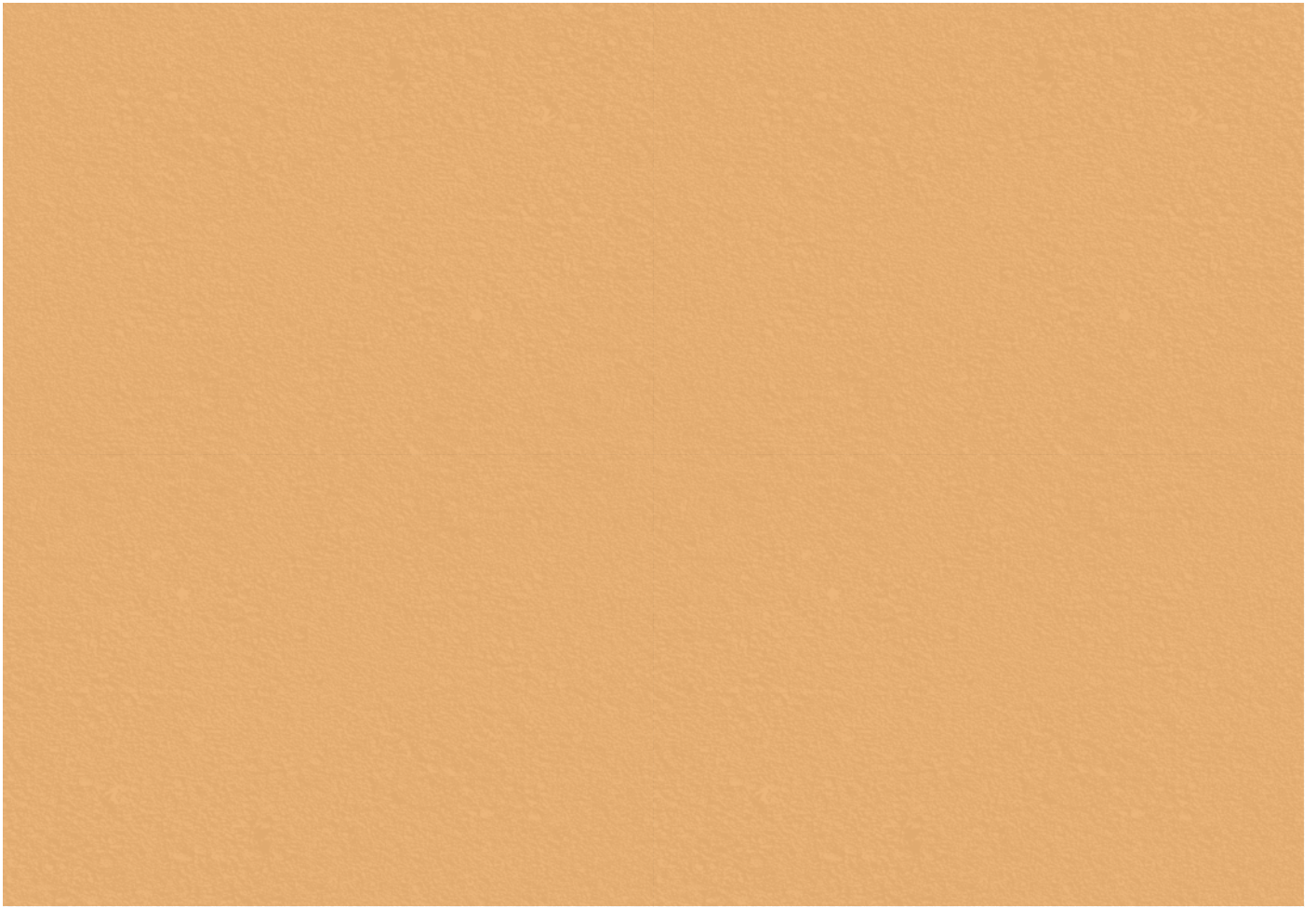

base: coconut rum
accent: personality deficit, the virgin larry

Exterior Building Materials

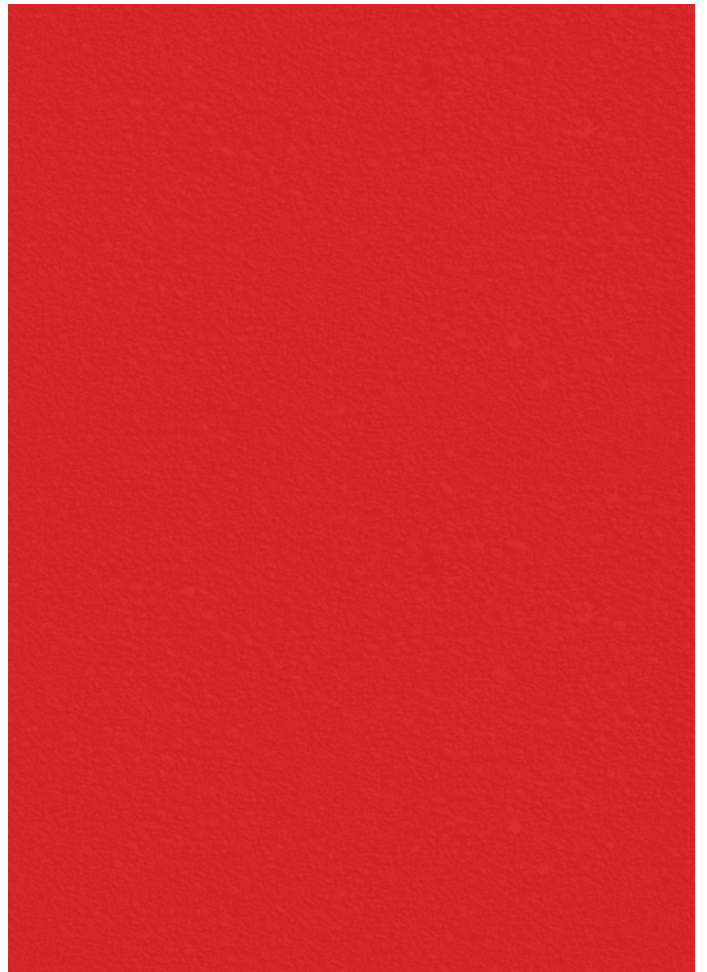
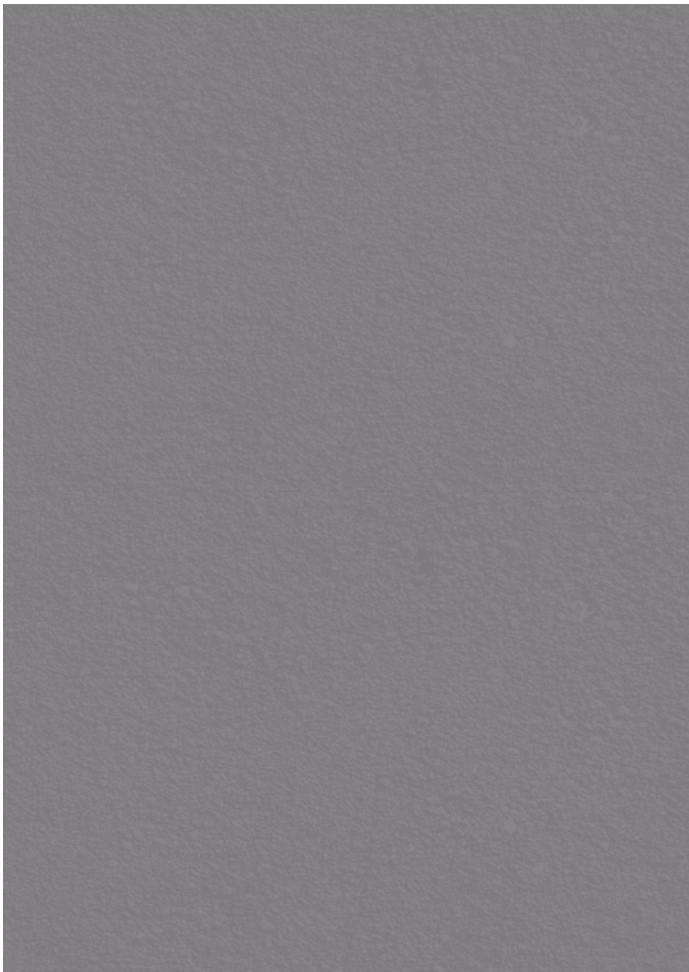
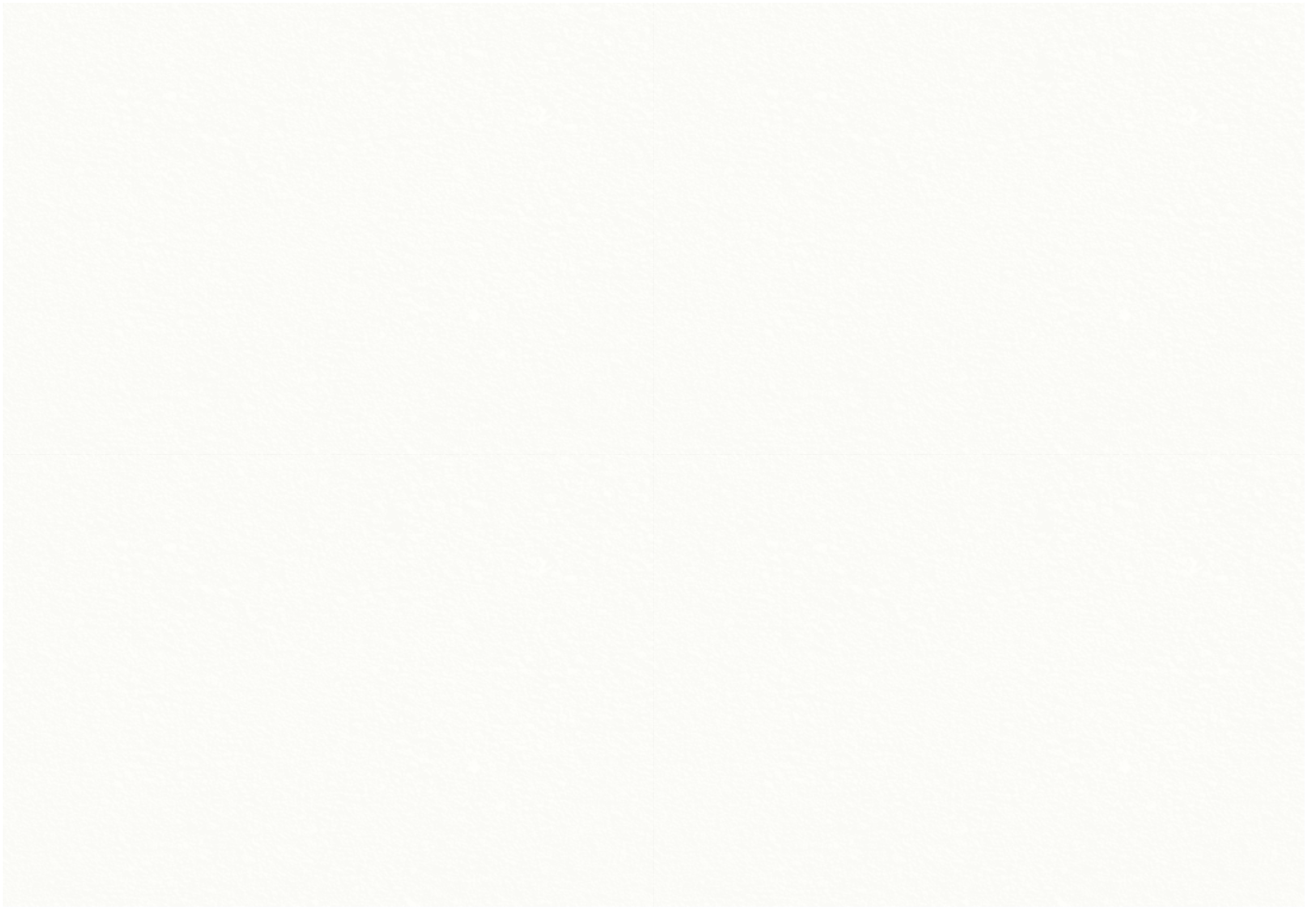

base: writer's block
accent: spunky craft room, daddy's secret

Exterior Building Materials

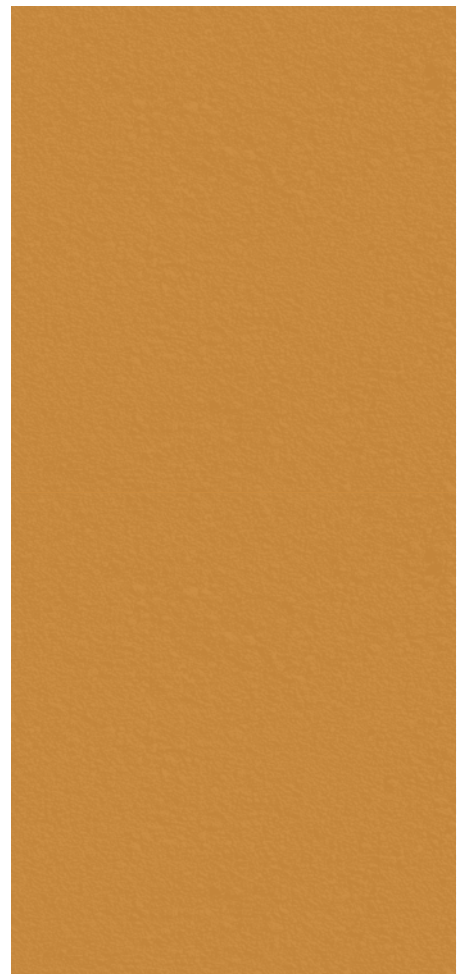
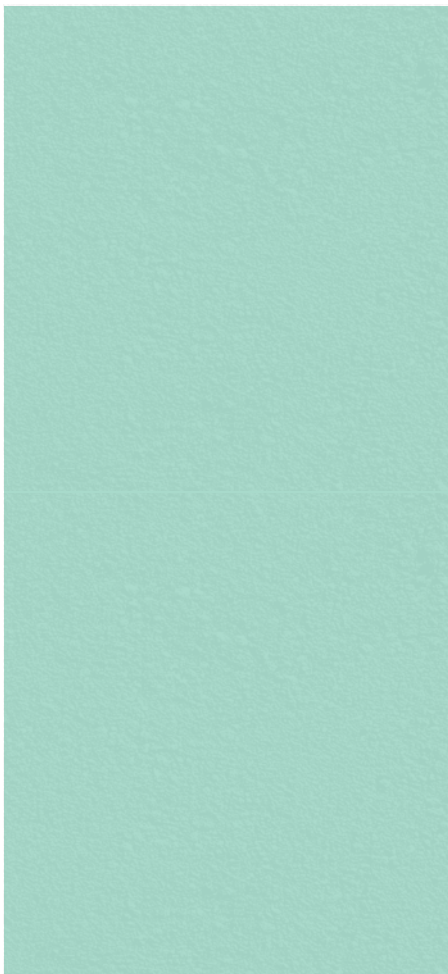

base: little league allstar
accent: loose change, writer's block, december tan

Exterior Building Materials

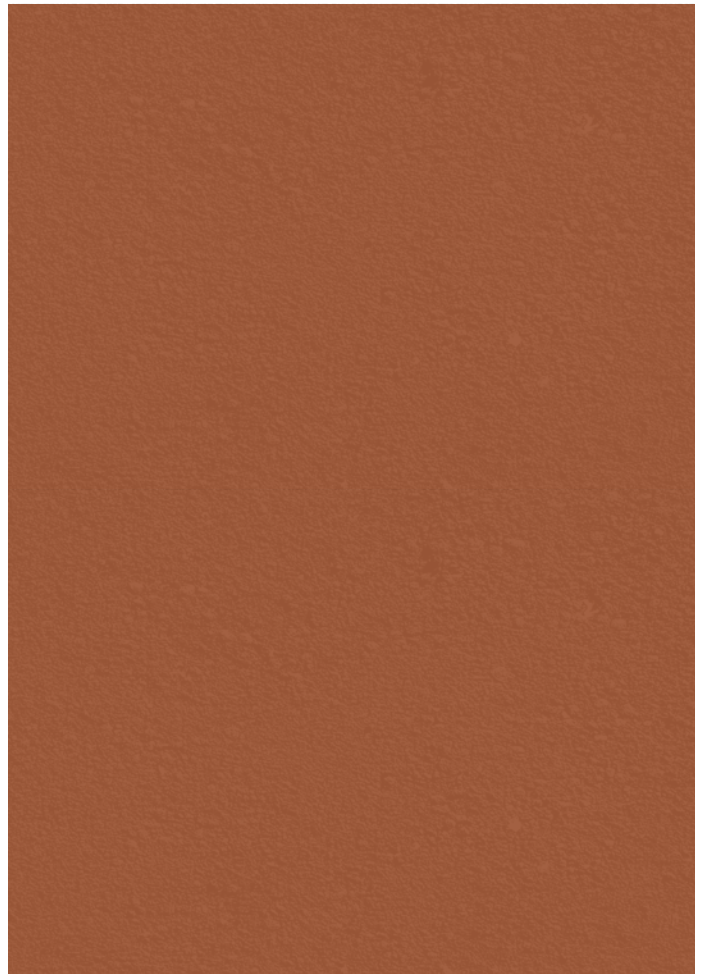
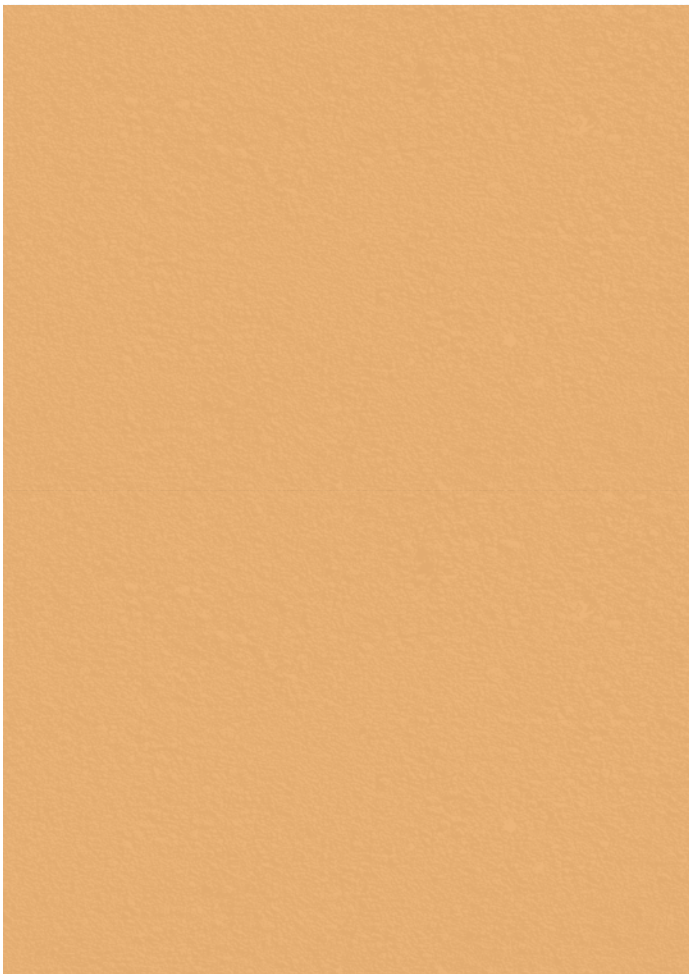
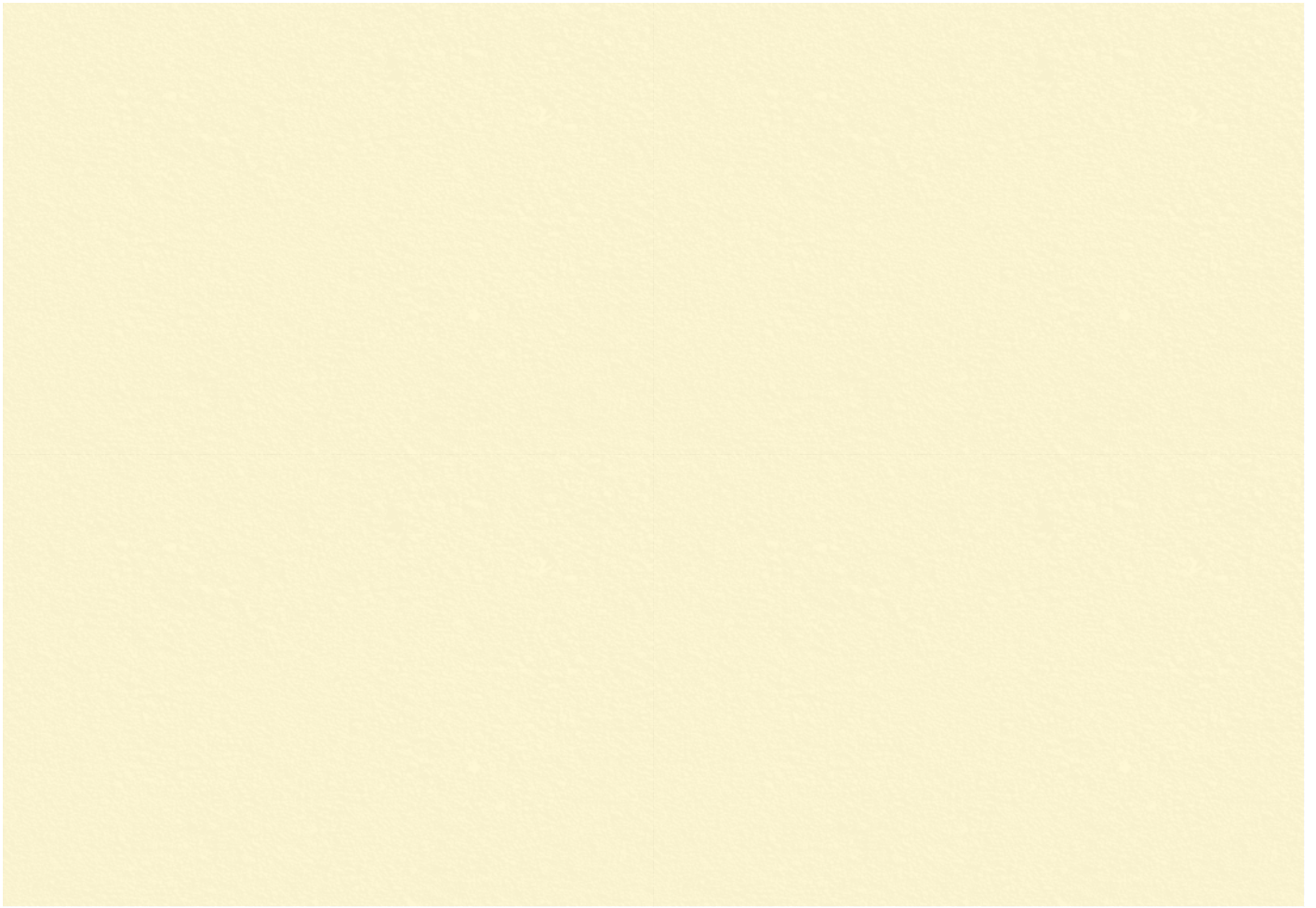

base: kale salad
accent: coconut rum, bad intentions

Exterior Building Materials

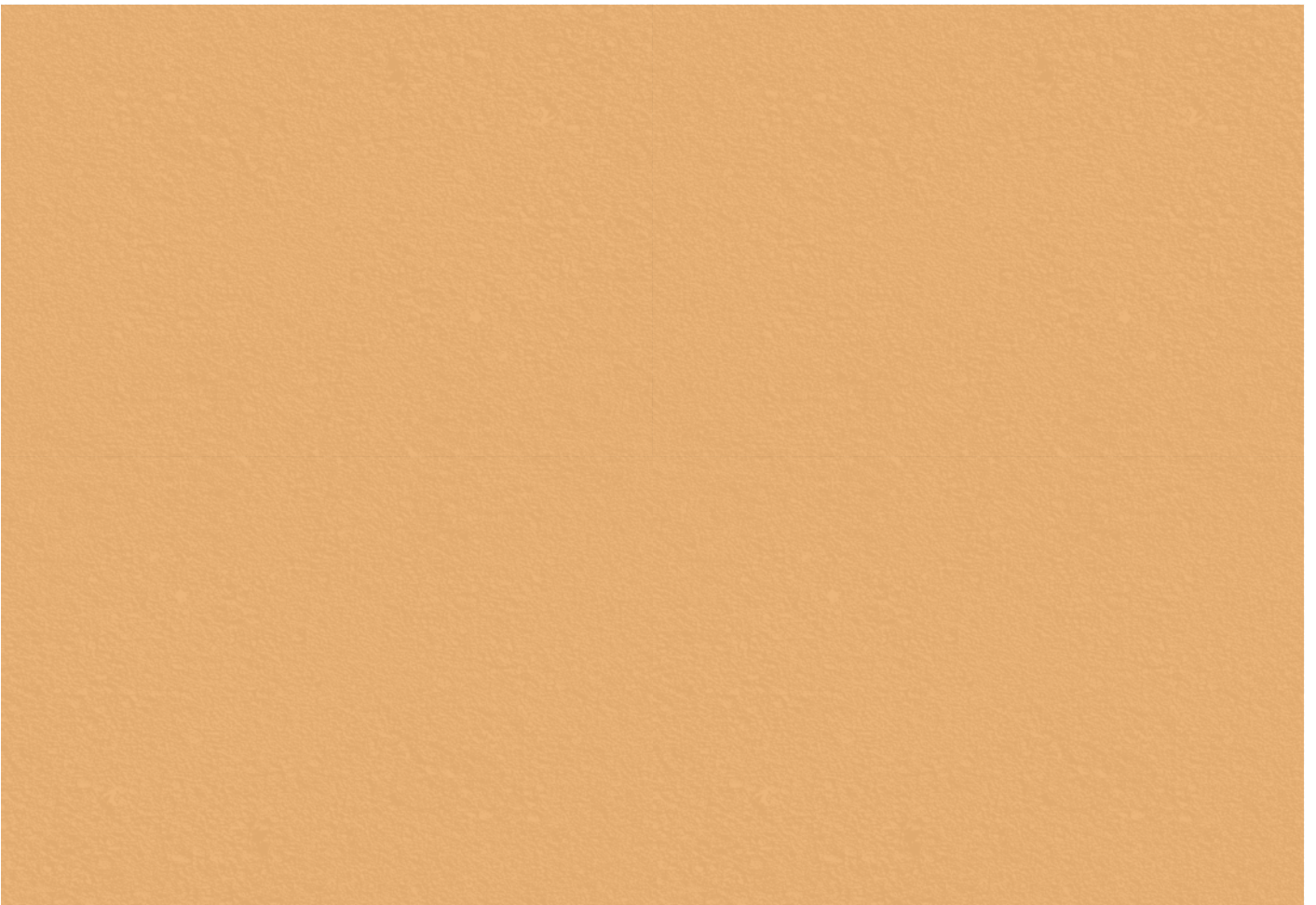
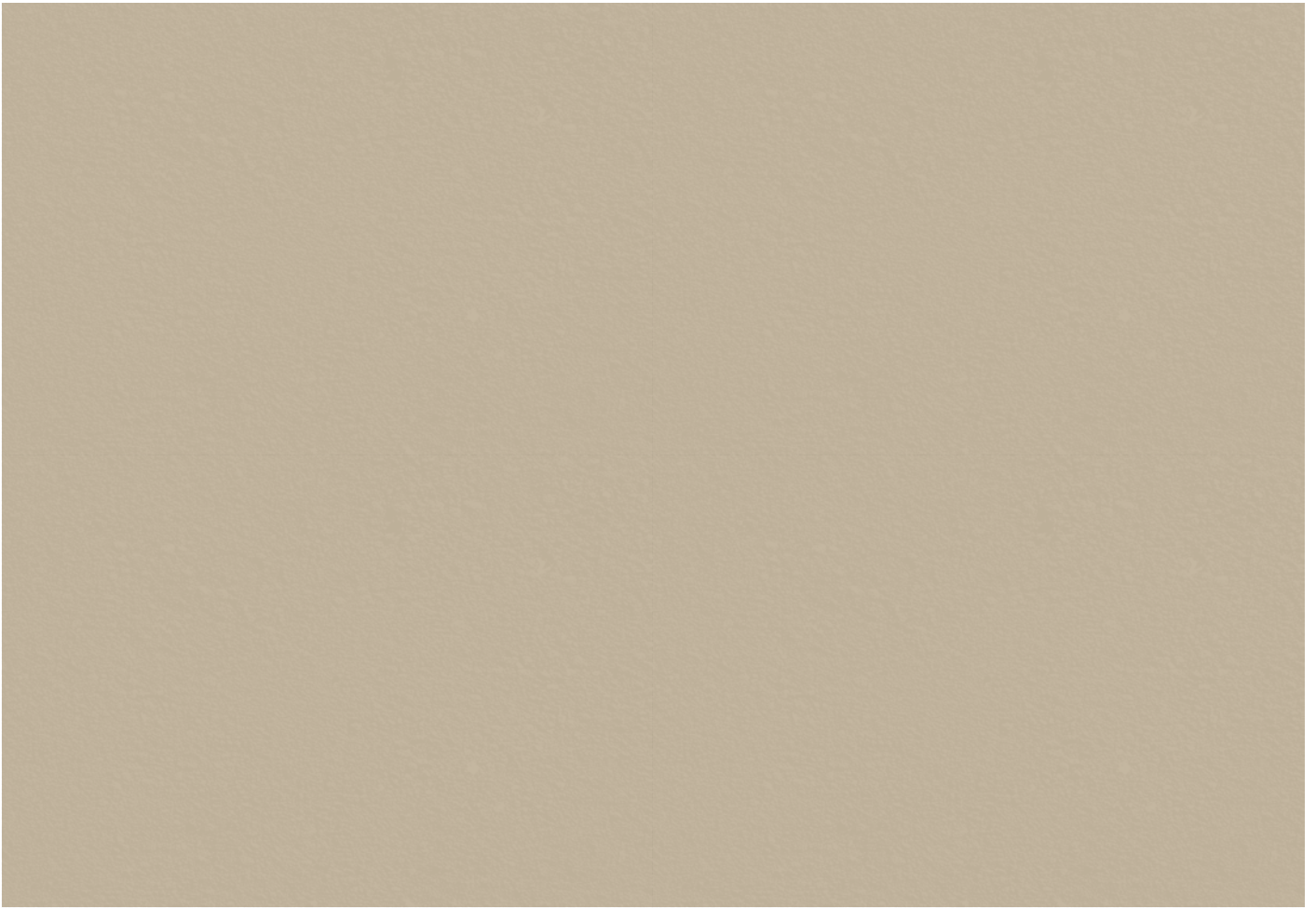

base: cigarette box
accent: coconut rum

Exterior Building Materials

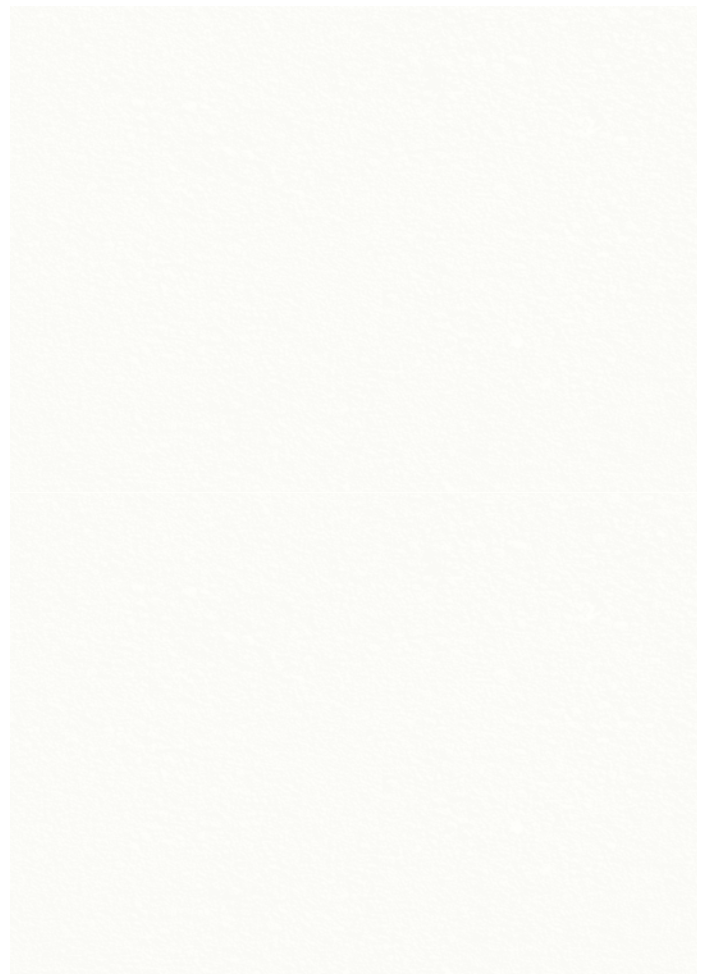
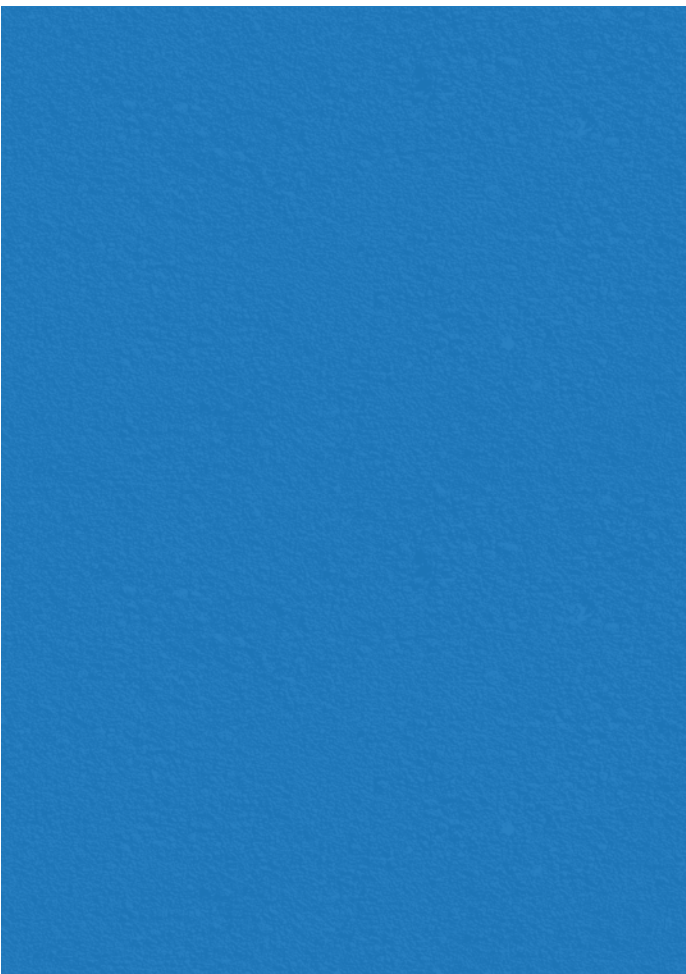
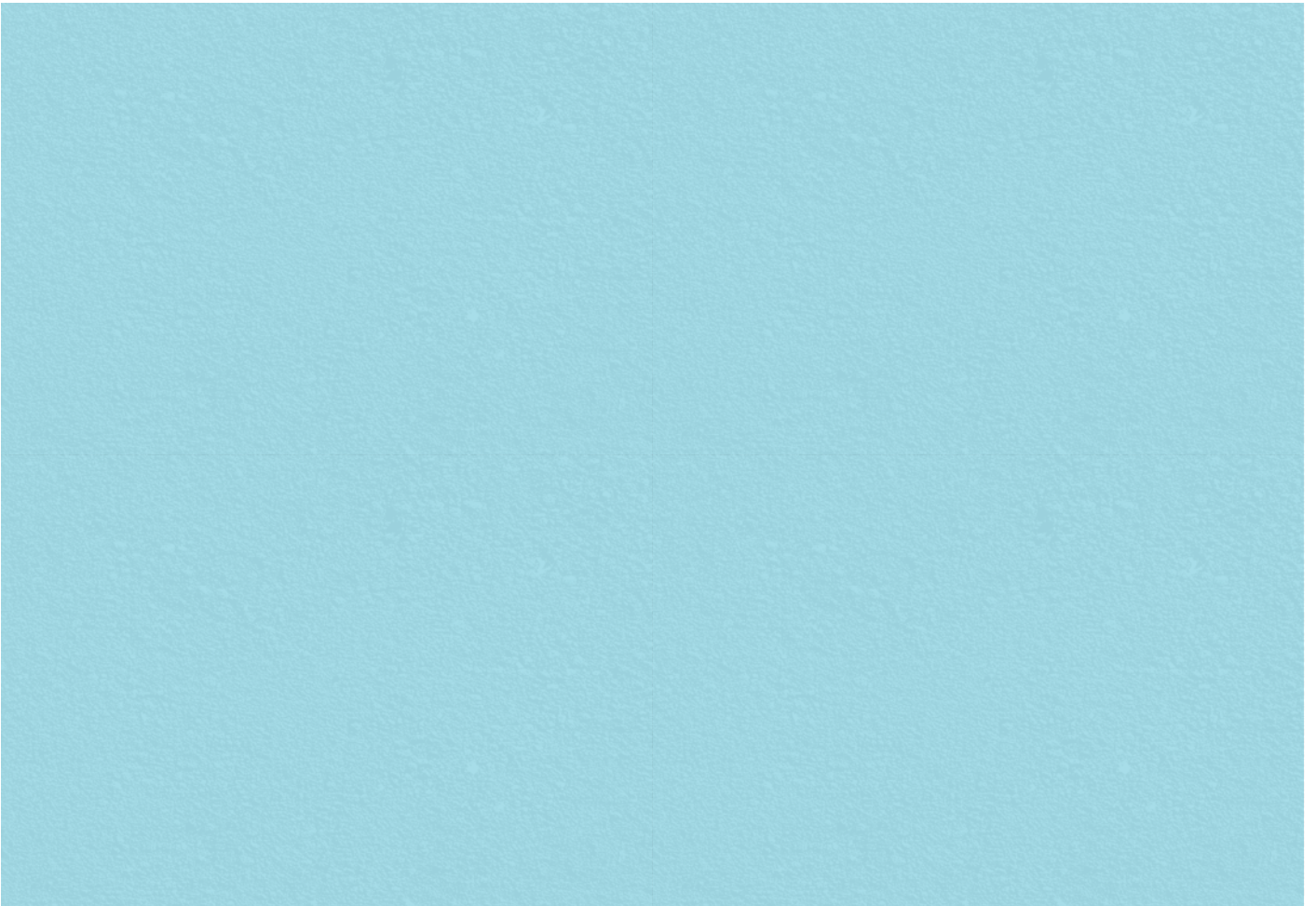

base: walking on sunshine
accent: laundry detergent, writer's block

Exterior Building Materials

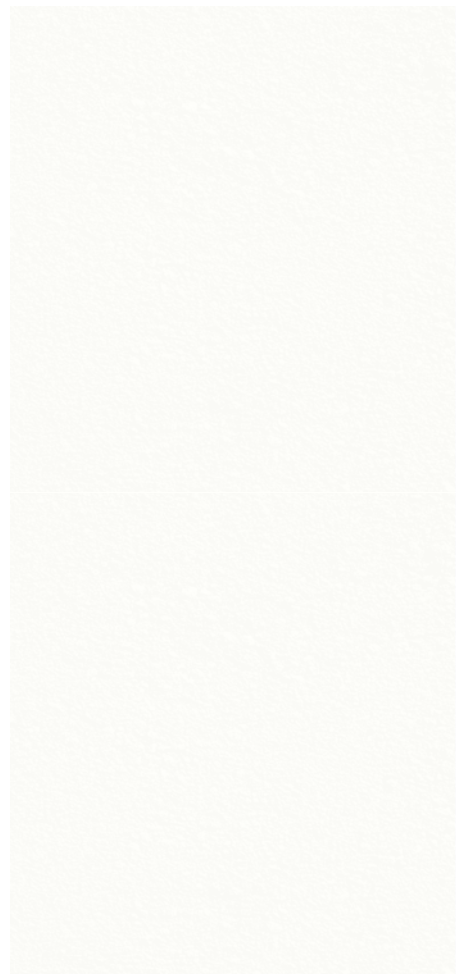

base: shotgun wedding
accent: poseidon's hot tub, writer's block, spilled milk

Exterior Building Materials

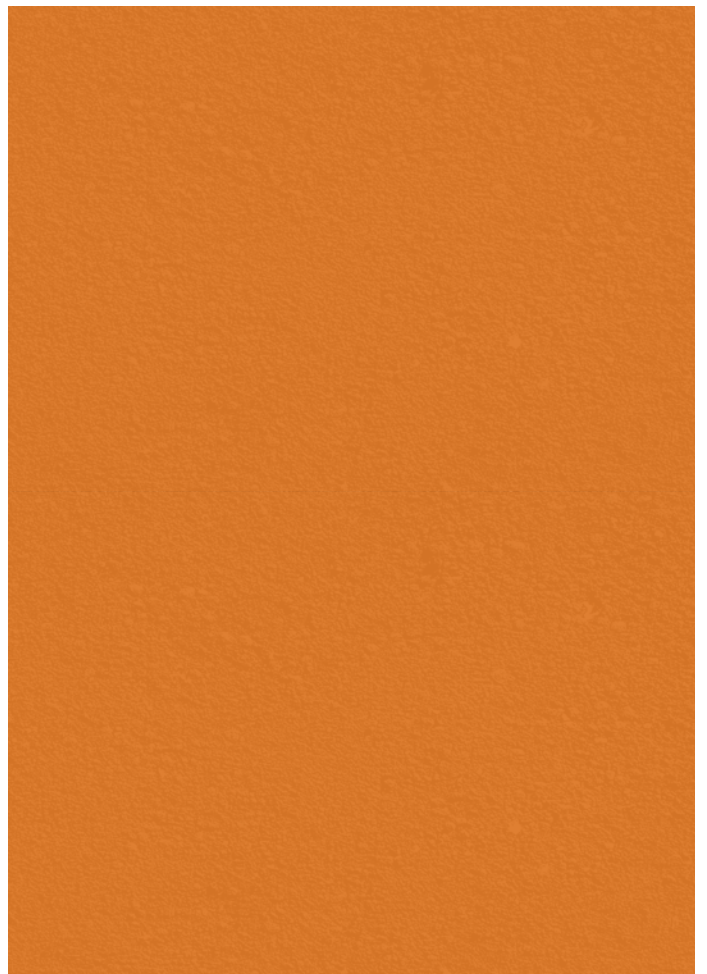
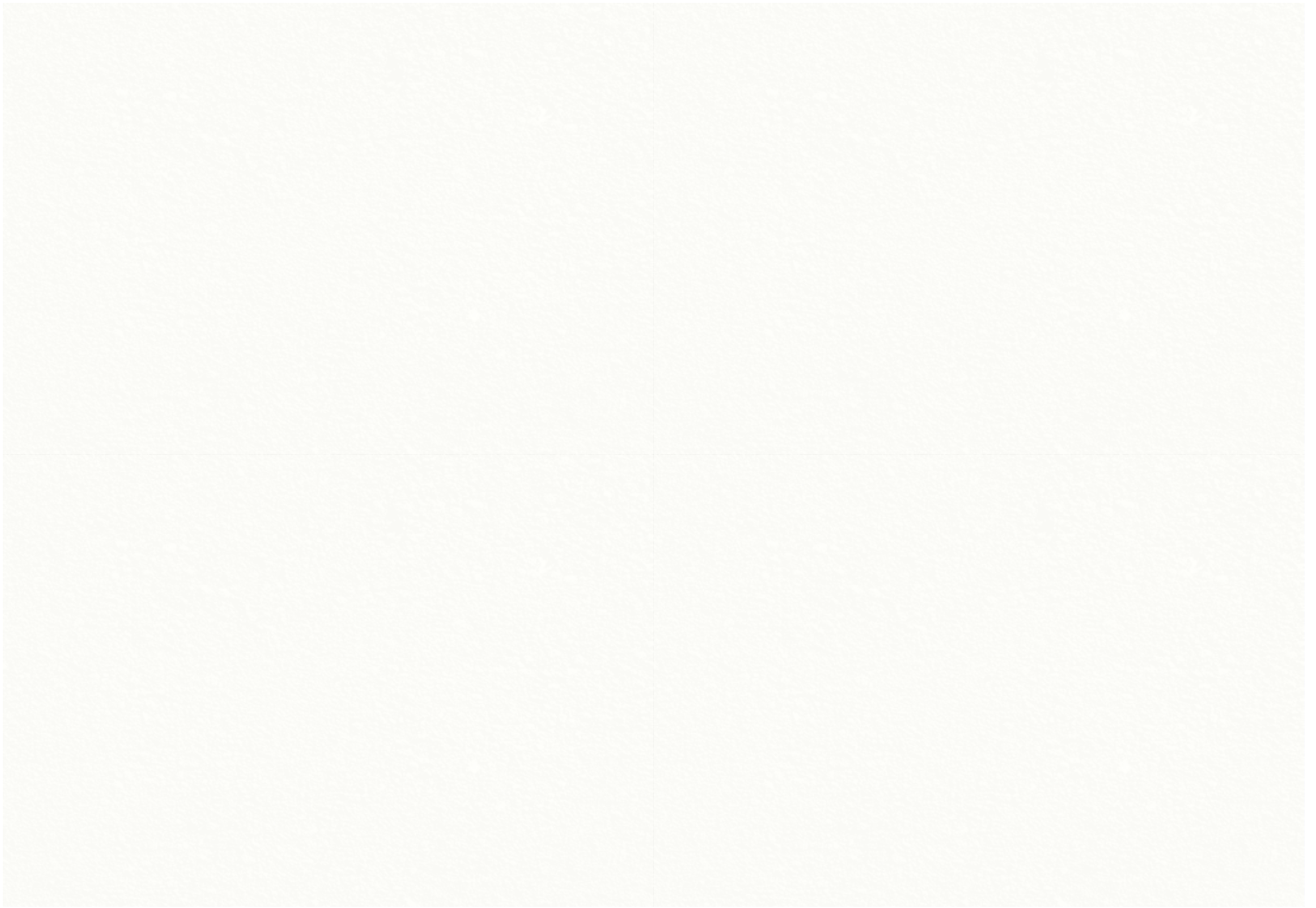

base: writer's block
accent: tax evasion, morning spritz

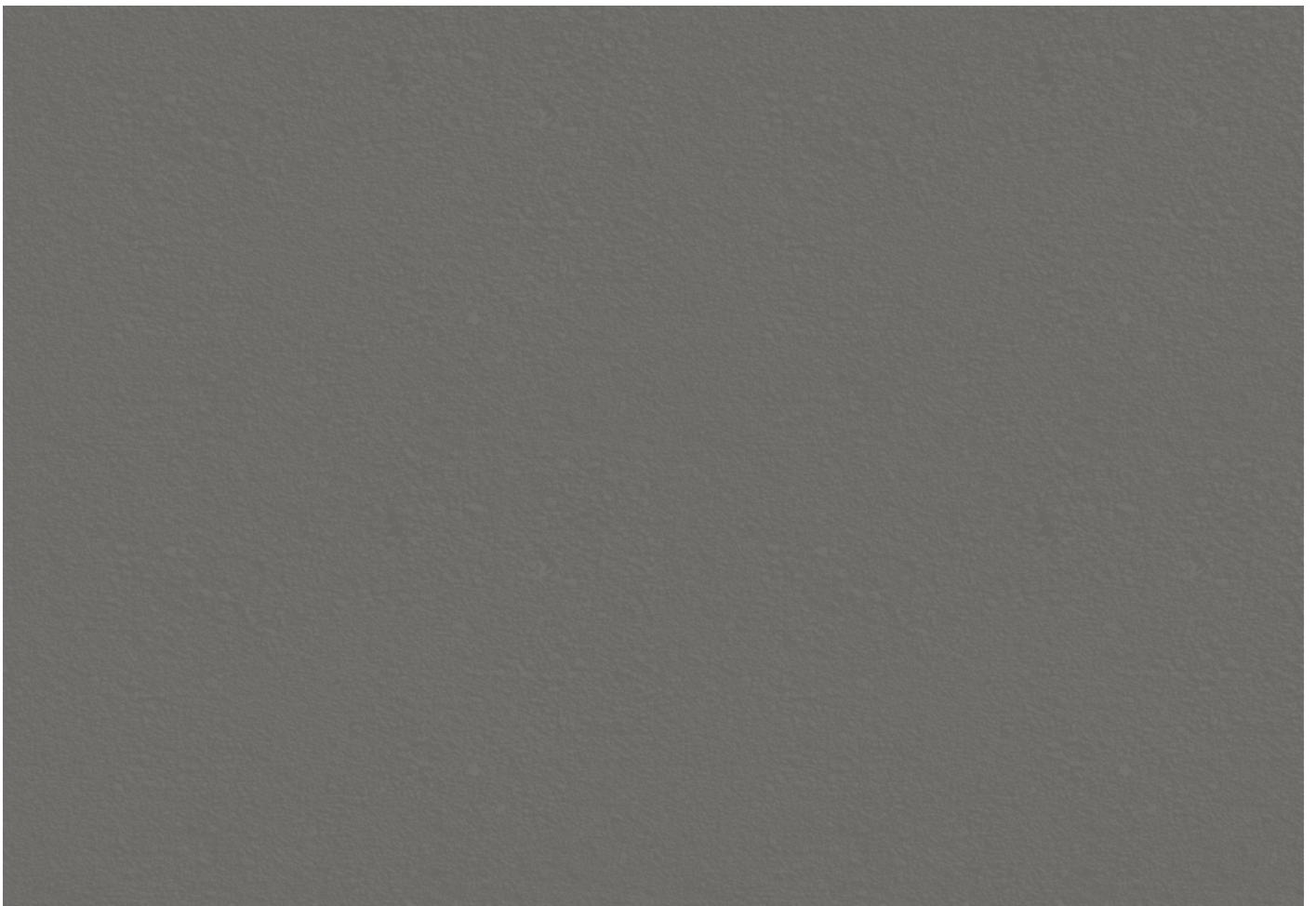
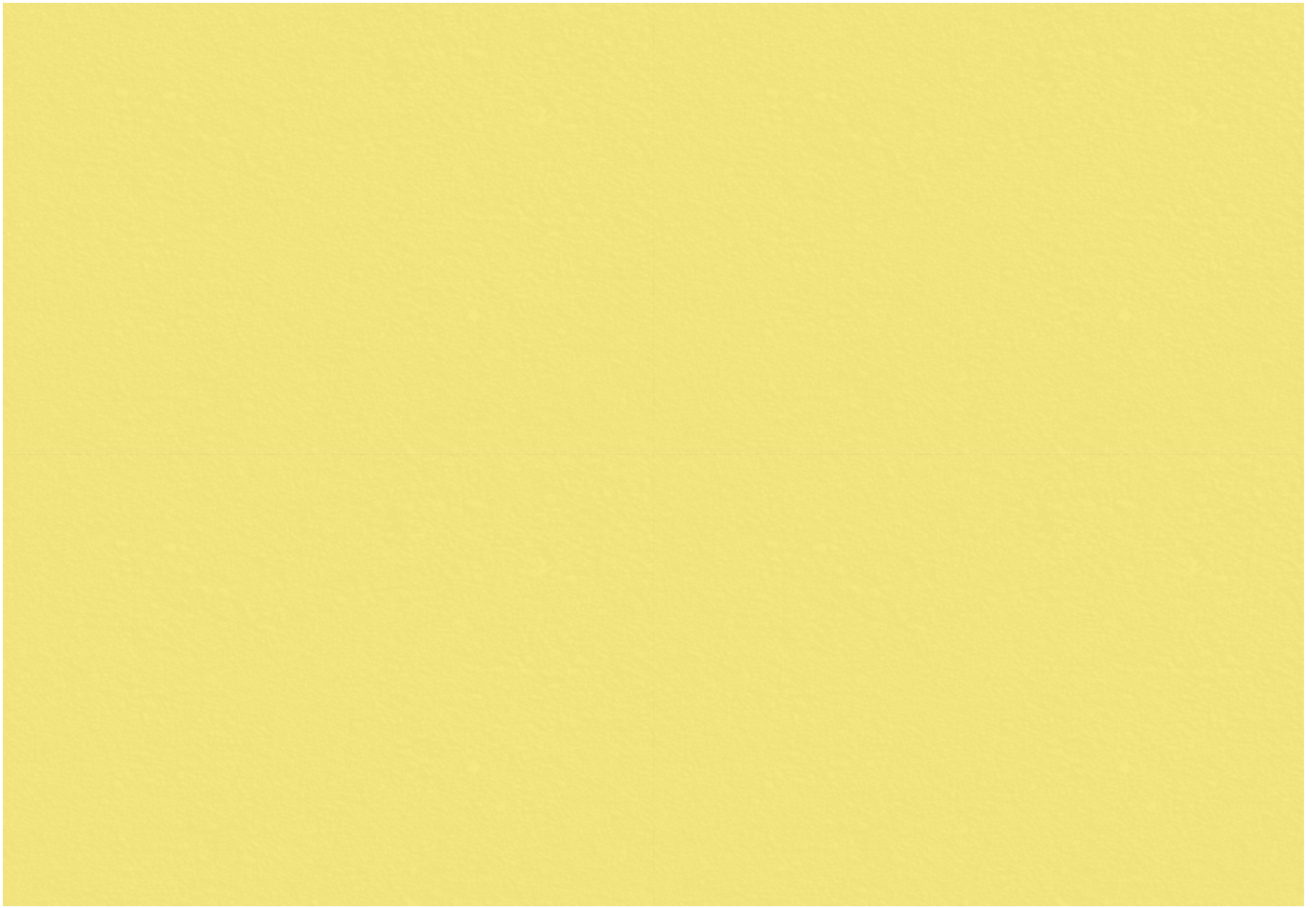

base: personality deficit
accent: side hustle

Exterior Building Materials

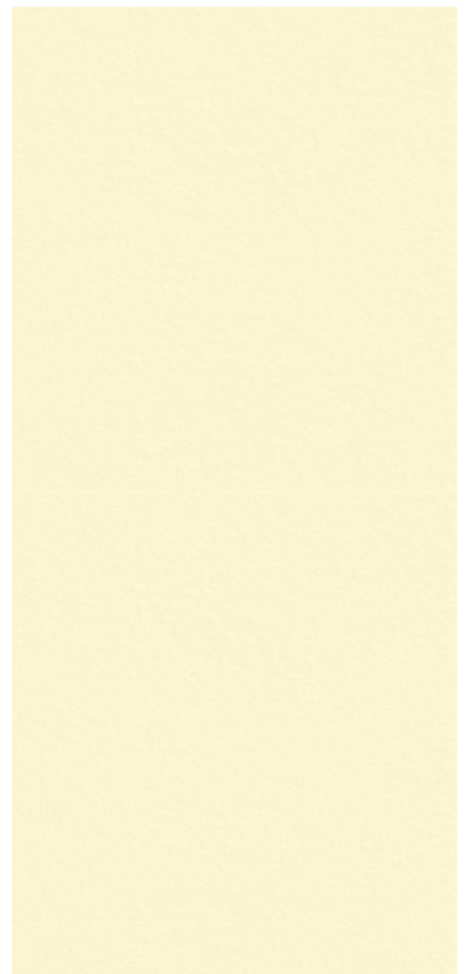
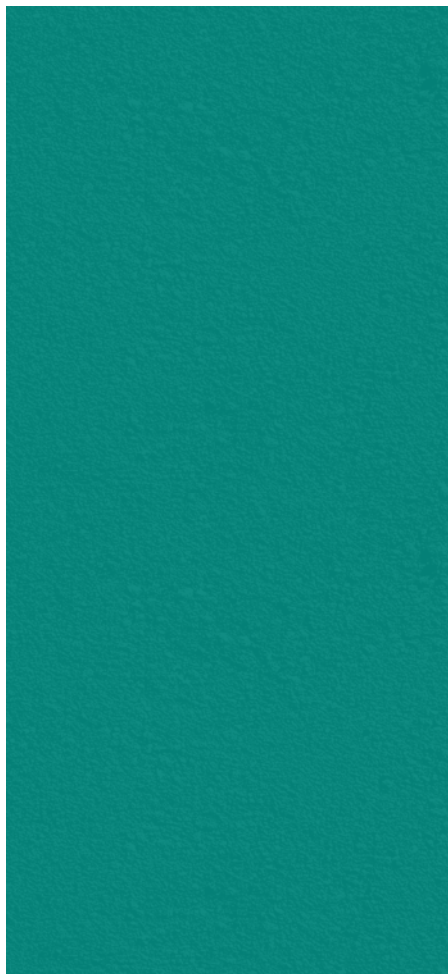



base: bedside toy
accent: writer's block, questionable taste, kale salad

Roof Profiles

Adam Liu, Stephen Marinelli

SEPARATED.....

EXTENDED.....

GABLED.....

CROWNED.....

APPENDED.....

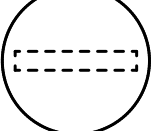
HIDDEN.....

Roof Profiles

40.3356438,18.2980103 / **39.911651, 18.244807** / 39.911079, 18.243997 / 39.913624, 18.245547 / **39.915060, 18.239209** / 39.9140966,18.238382 / 39.8881412,18.3269263 / 39.8854349,18.3342468 / 39.8943309,18.3308712 / 40.059713, 18.058366 / 39.963844, 18.360344/39.958981, 18.363090/**40.0862526,18.3508688**/39.962034, 18.362539/39.961210, 18.359676/39.837505, 18.364336/39.838002, 18.373387/39.839348, 18.376296/40.3668088,18.1801744/40.286811, 17.993885/40.2872078,17.9941615 / 40.2843555,17.9900692 / 40.284119,17.9875793 / 40.2866254,17.9941258 / **39.952095,18.222176** / 40.286811, 17.993885

40.3329991,18.2970226 / 39.910152, 18.245697 / 39.8927996,18.3289391 / 39.8943309,18.3308712 / **39.8878182,18.335712** / 39.960779, 18.365327 / 39.847620, 18.364581 / **40.0562132,18.0051689** / **40.114529, 18.307067** / 40.2663599,18.3350377 / 40.3280224,18.0919886 / **40.024603,18.1441708** / 40.0504997,18.1336429

39.913165, 18.246071 / 39.912509, 18.248598 / 39.906895, 18.246047 / 39.8940998,18.3309244 / **40.023567,18.1443648**

40.3347895,18.2990629 / 39.915057, 18.238919 / 39.912113, 18.242194 / **39.8928115,18.3283319** / 39.8939503,18.3310502 / 40.059718, 18.058588 / **40.059718, 18.054899** / 40.059337, 18.055293 / 39.965166, 18.358571 / 39.963536, 18.360585 / 39.838081, 18.376508 / 39.838519, 18.376754 / 40.285806, 17.994361 / 40.294096,17.9885658 / 40.1715086,18.0291318 / **39.86042,18.3001543** / 39.8667386,18.290094 / 39.8631443,18.2975641 / 40.3061315,18.3972195 / **40.3027784,18.3954196** / 40.2955281,18.4046477 / 39.800728, 18.357704 / 40.0888636,18.4074512 / 40.0872322,18.4073626 / 40.0885348,18.4081458

40.332688,18.2971266 / **40.3339559,18.298866** / 40.335199,18.2983447 / 40.061498, 18.052479 / **40.059972, 18.051919** / 39.959519, 18.363253 / 40.056902,18.0084974 / **40.0849926,18.3453851** /

40.3360451,18.2981485 / 39.958701, 18.363915 / 39.8560975,18.3016835 / 39.8332375,18.3534228

Roof Profiles

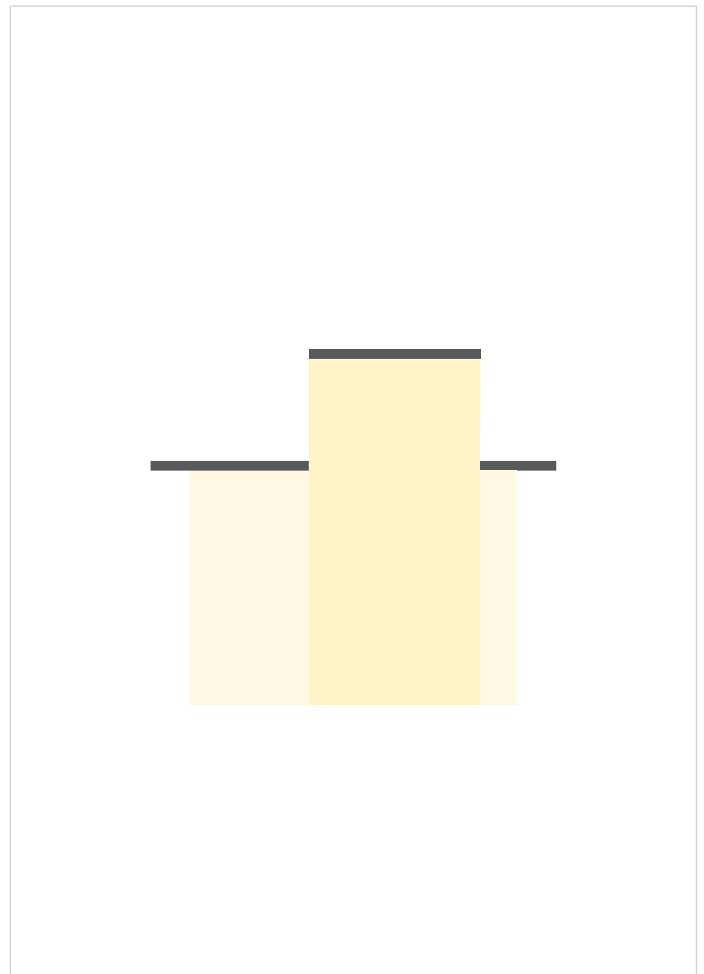
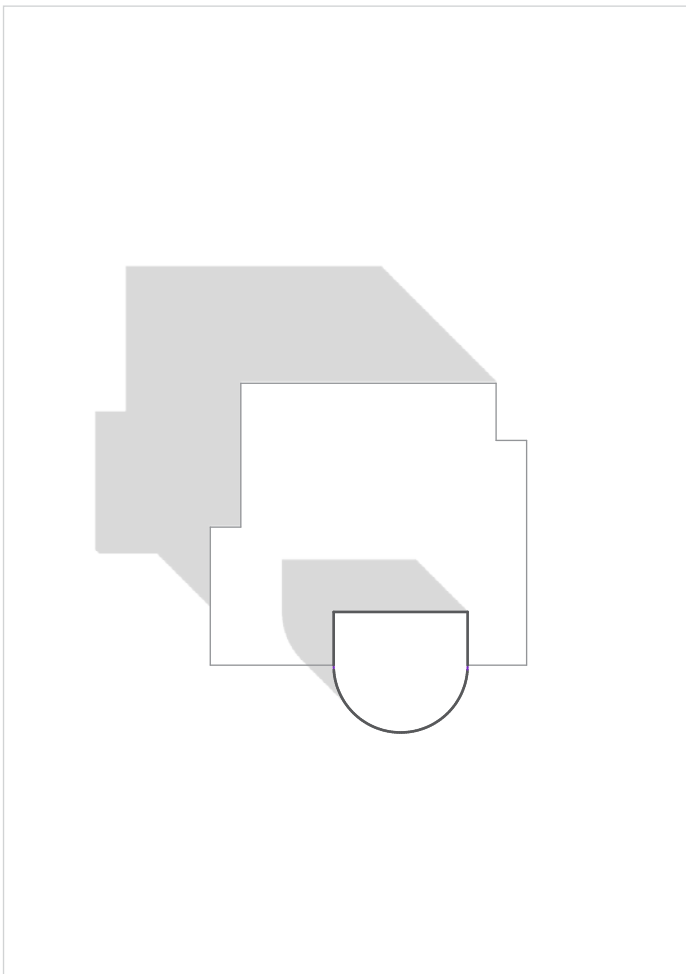
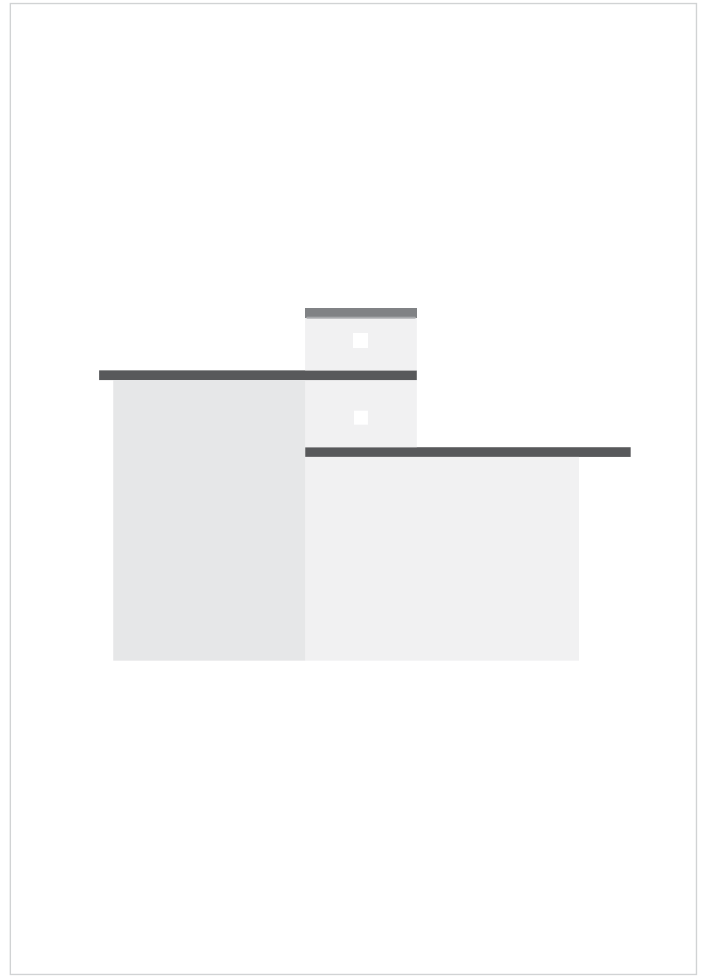
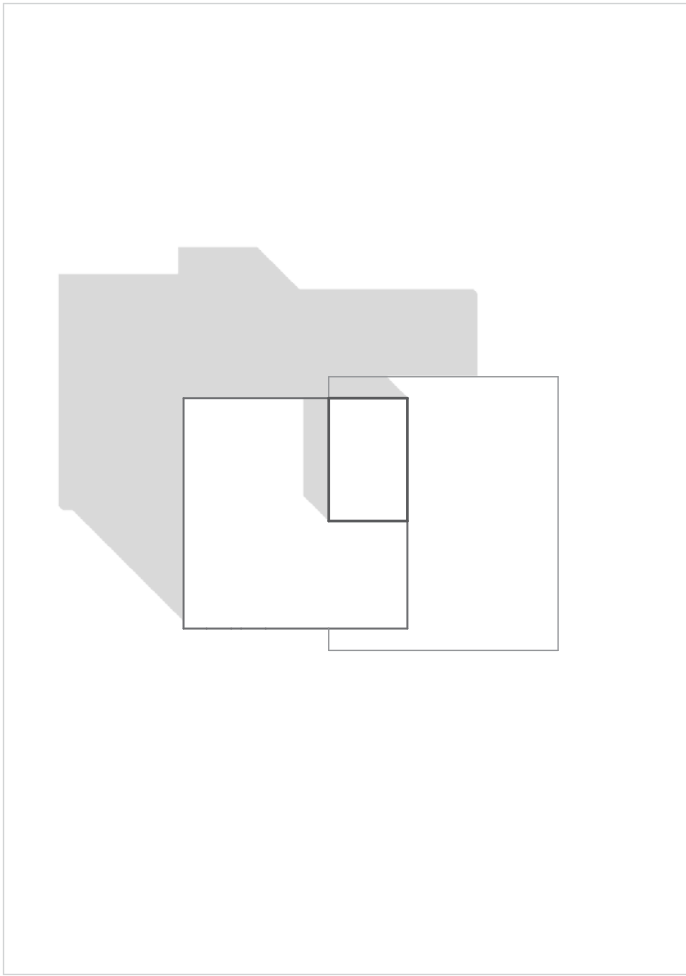

40.086252,18.350868
39.952095,18.222176

Roof Profiles

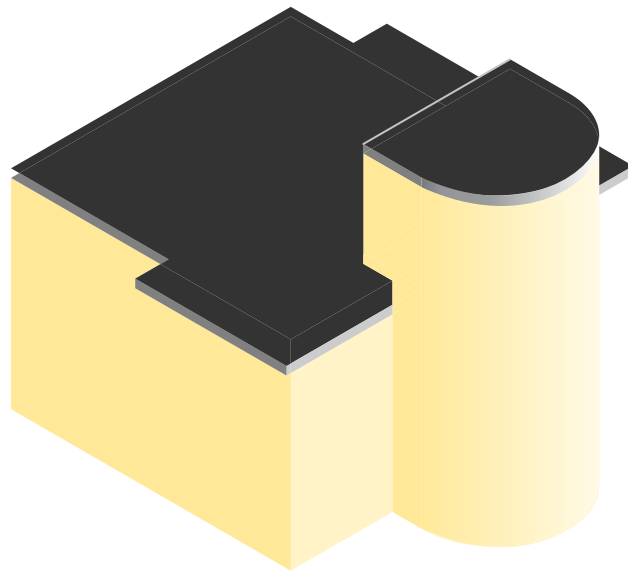
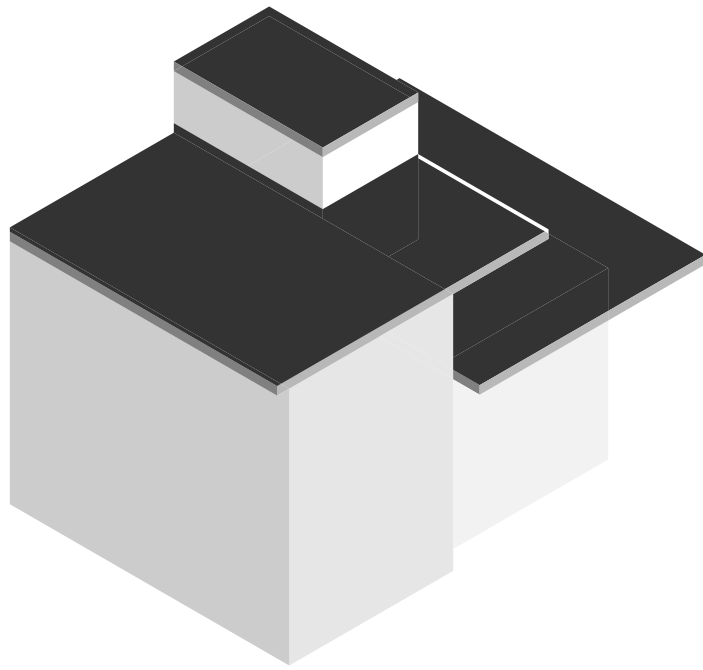

Roof Profiles

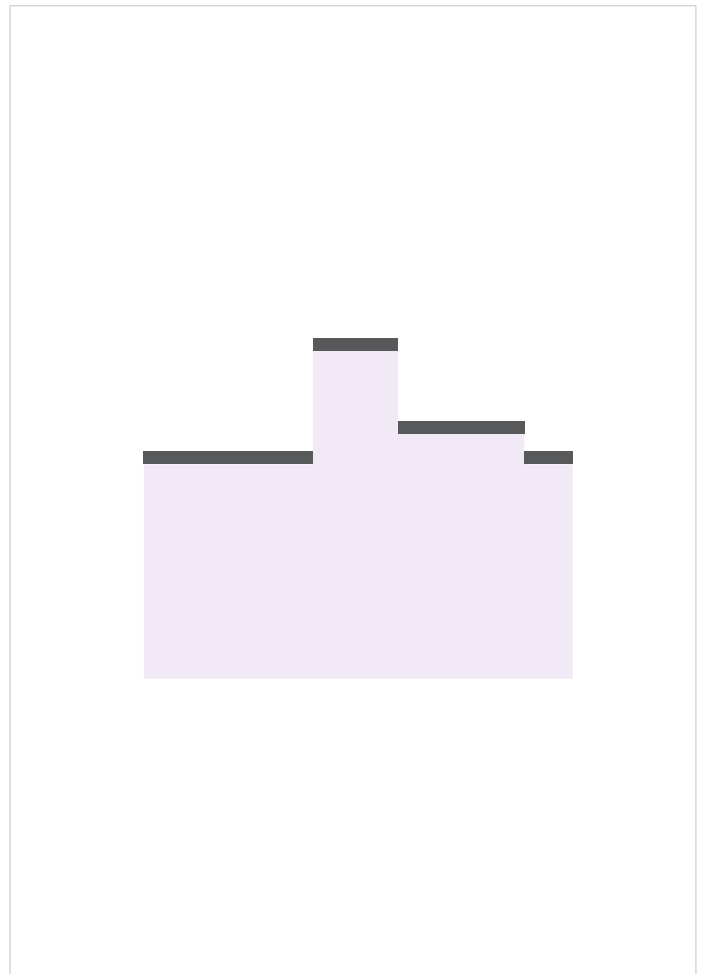
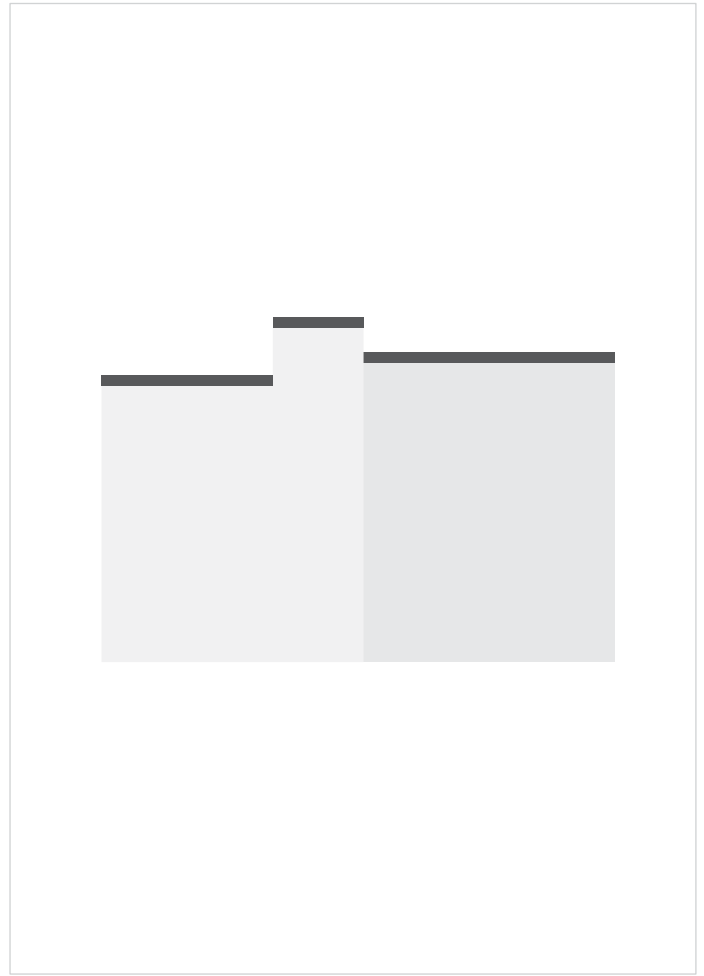
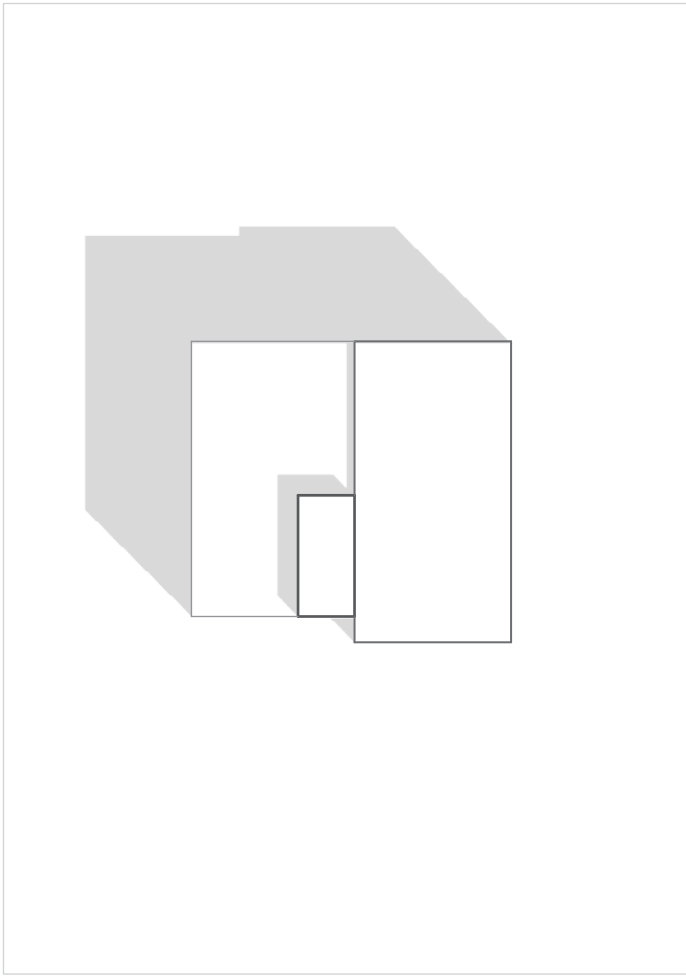

39.911651,18.244807
39.915060,18.239209

Roof Profiles

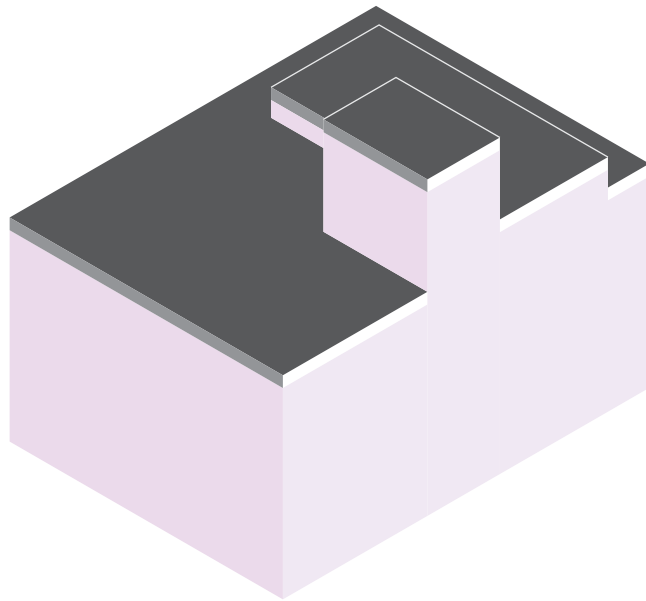
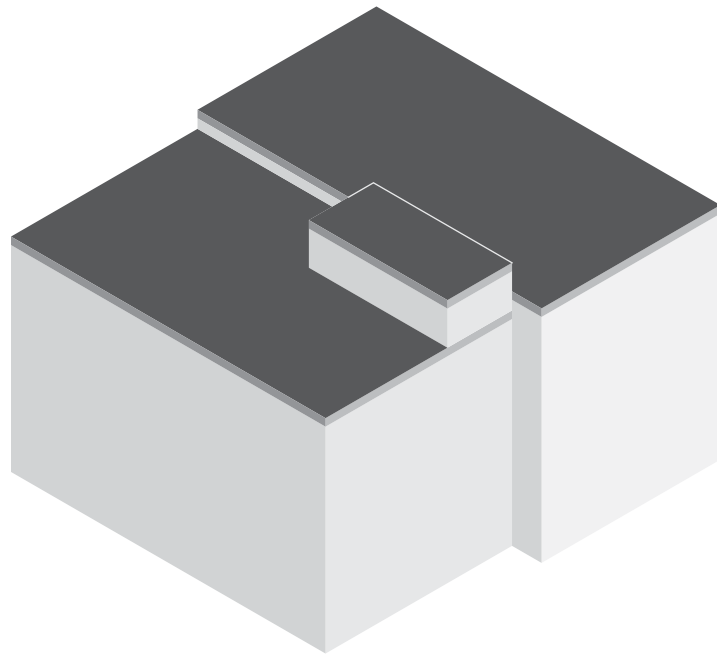

Roof Profiles

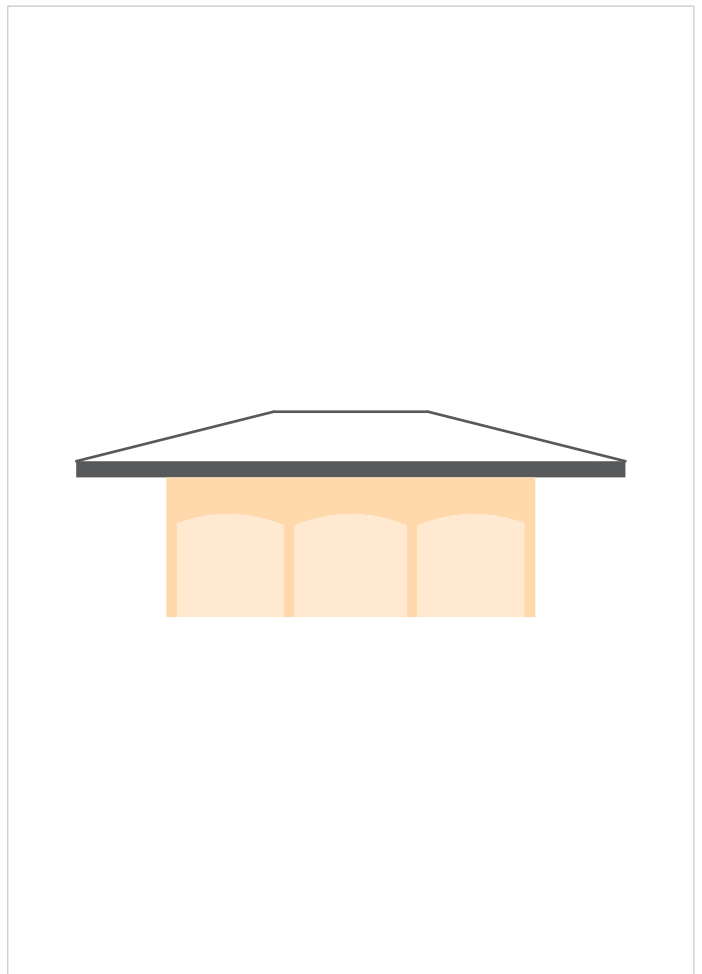
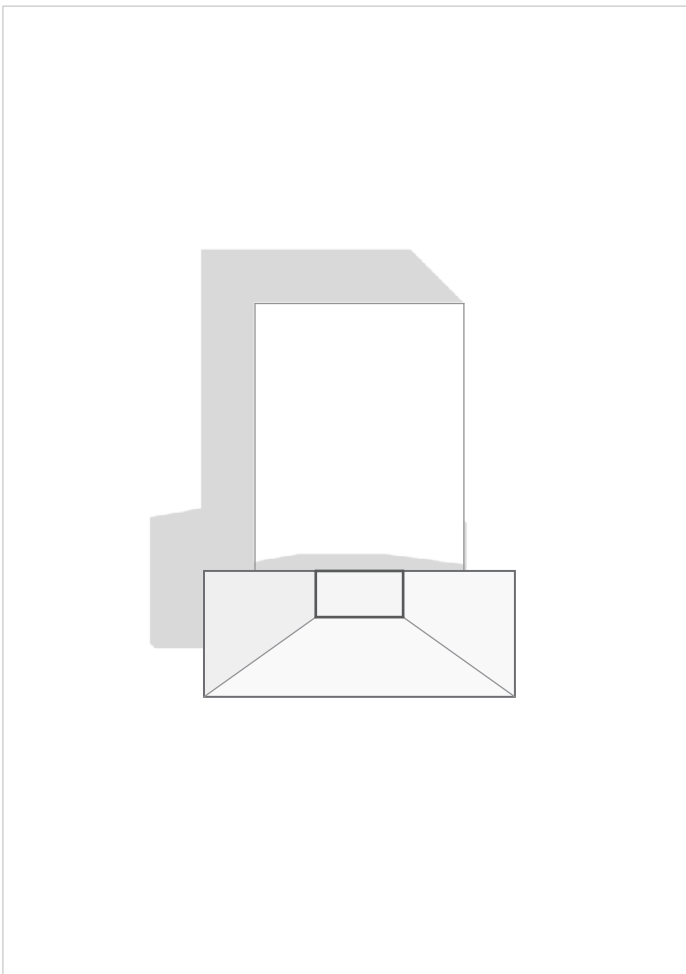
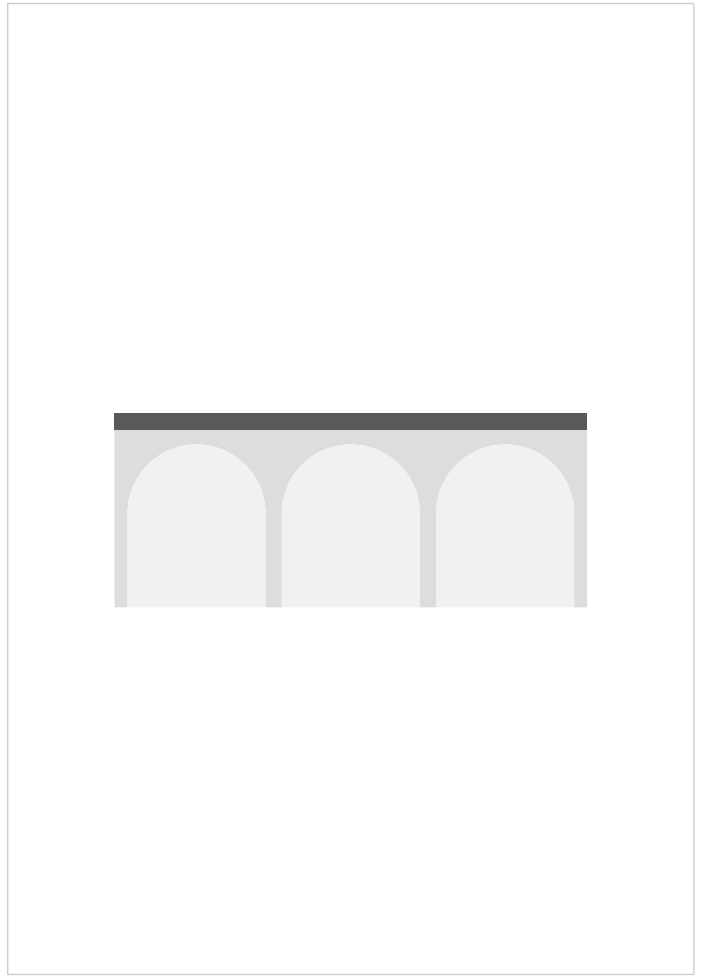
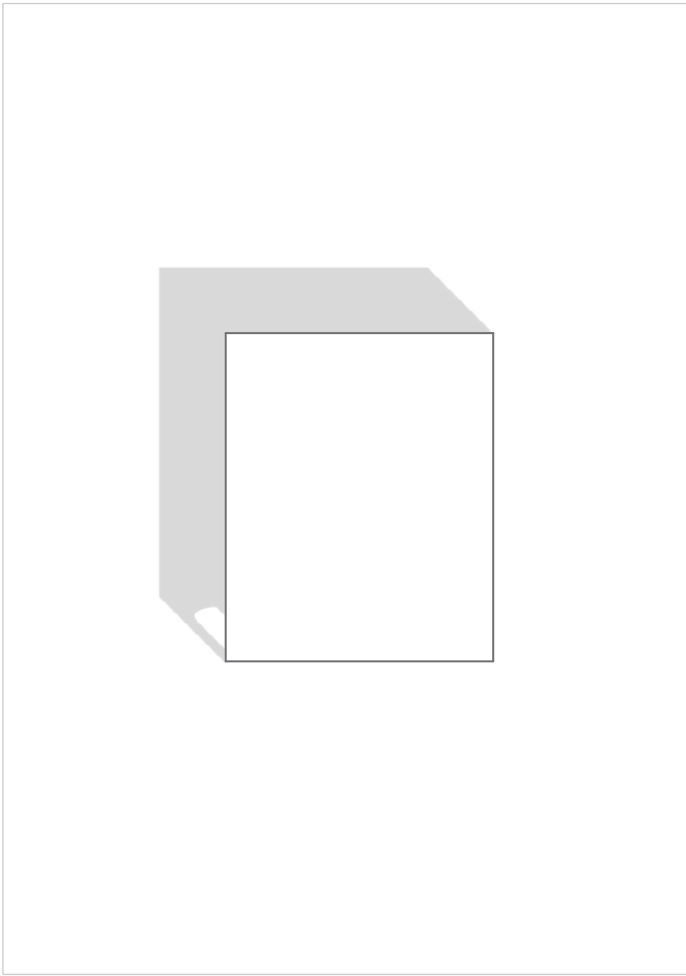

39.887818,18.335712
40.024603,18.144170

Roof Profiles

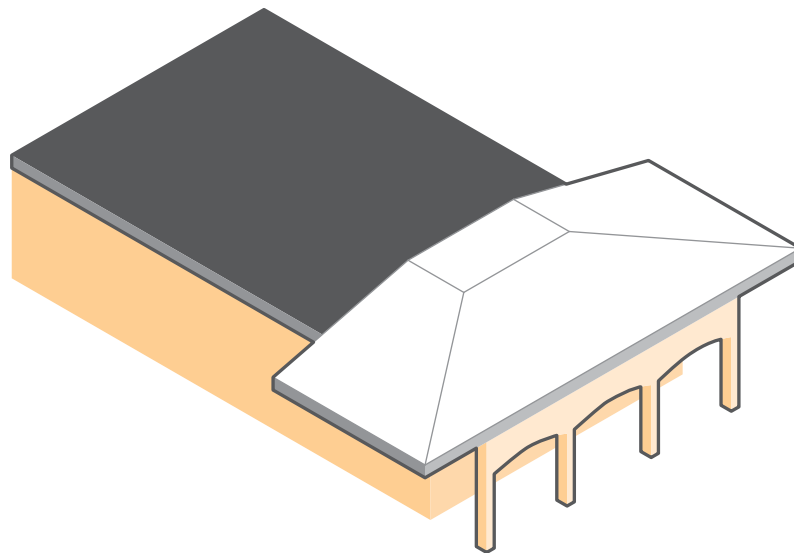
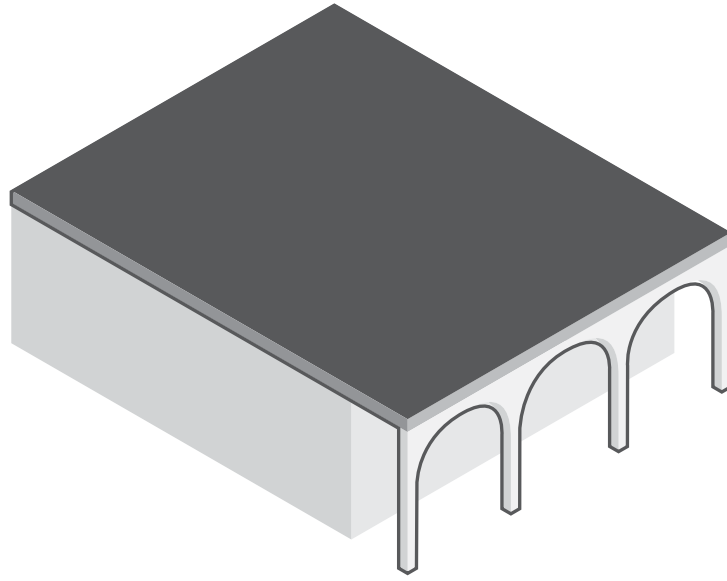

Roof Profiles

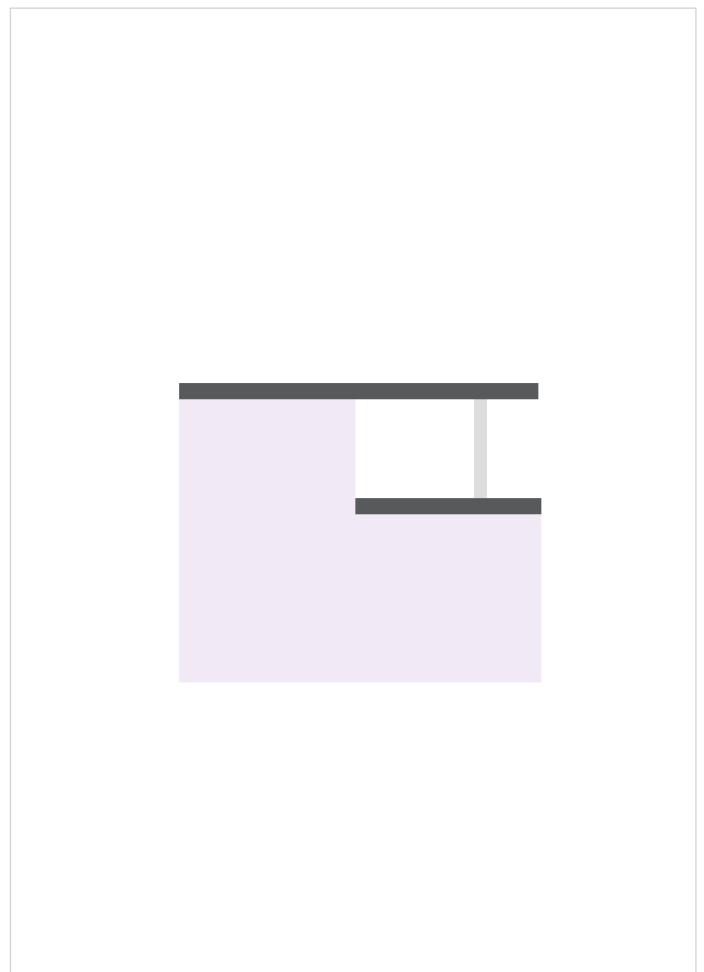
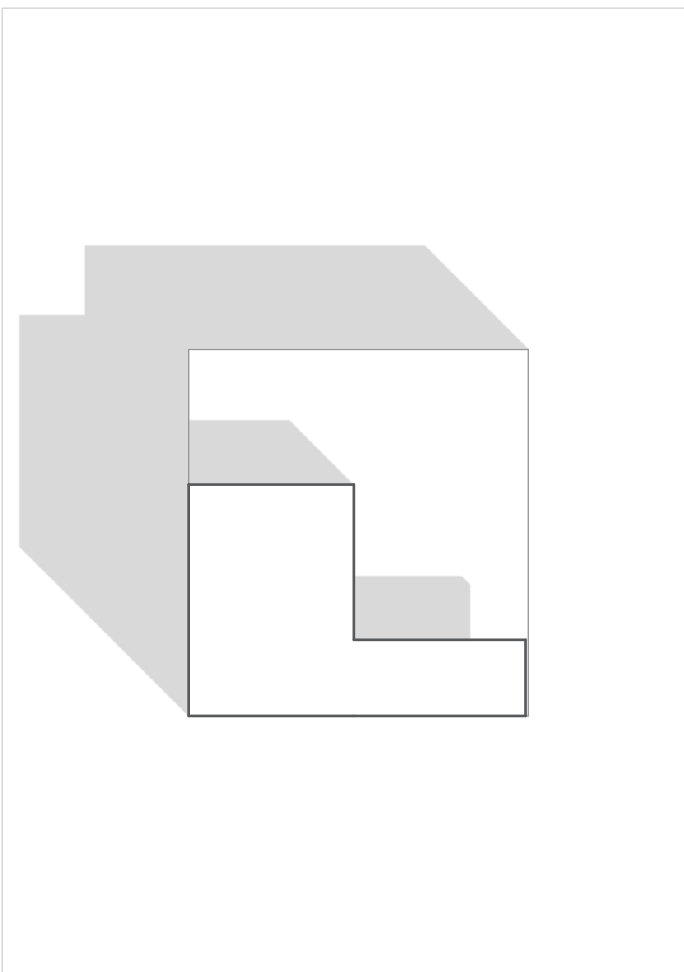
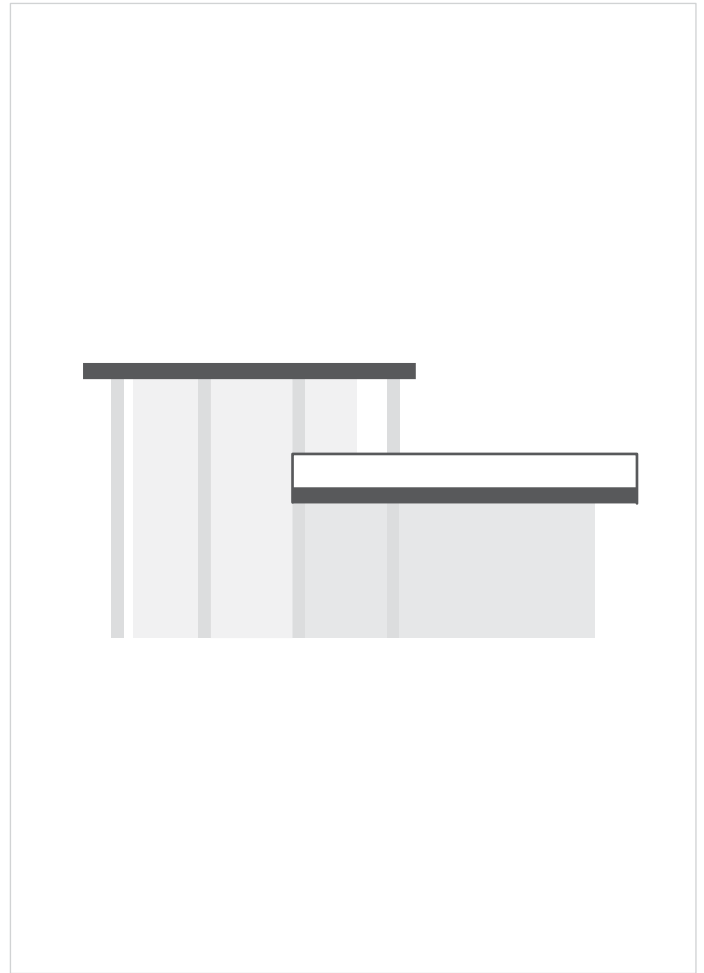
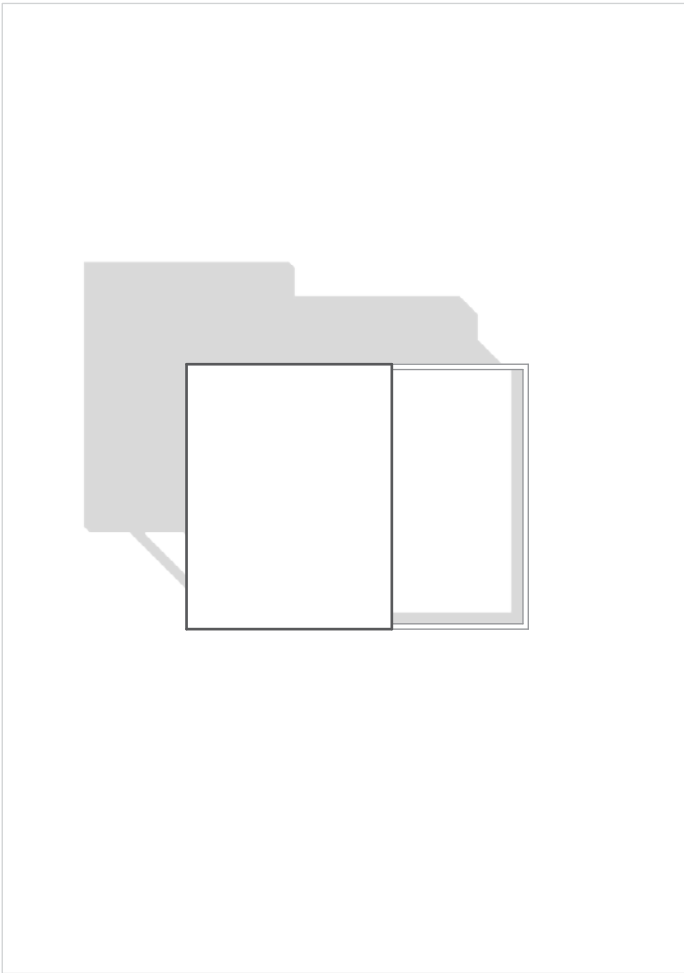

40.056213,18.005168
40.114529,18.307067

Roof Profiles

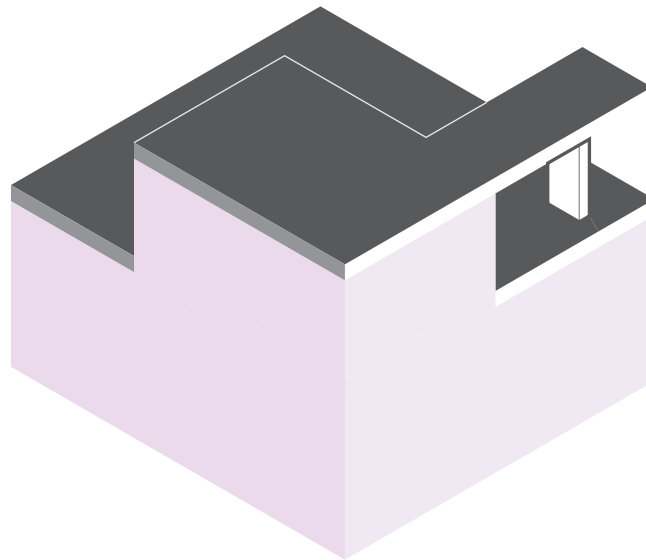
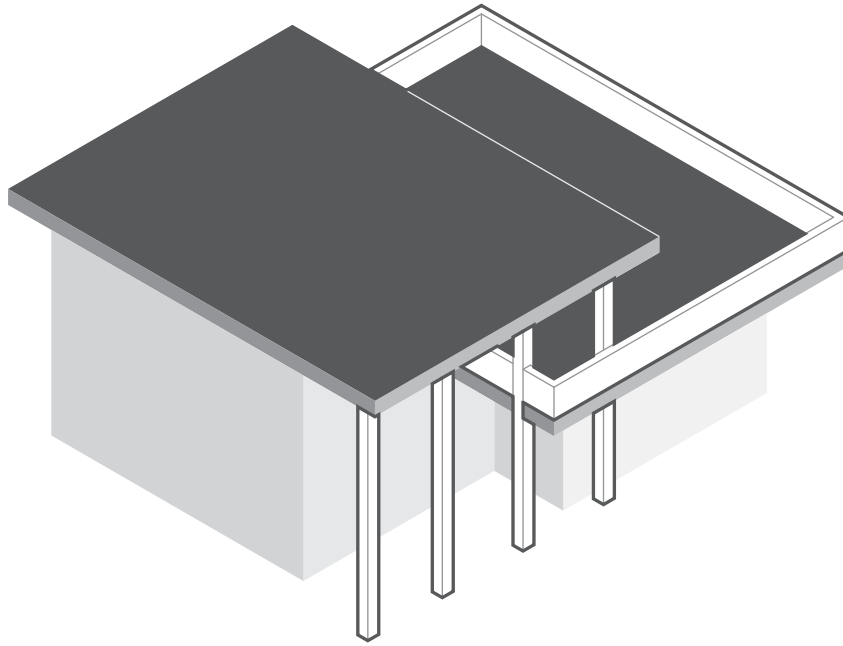

Roof Profiles

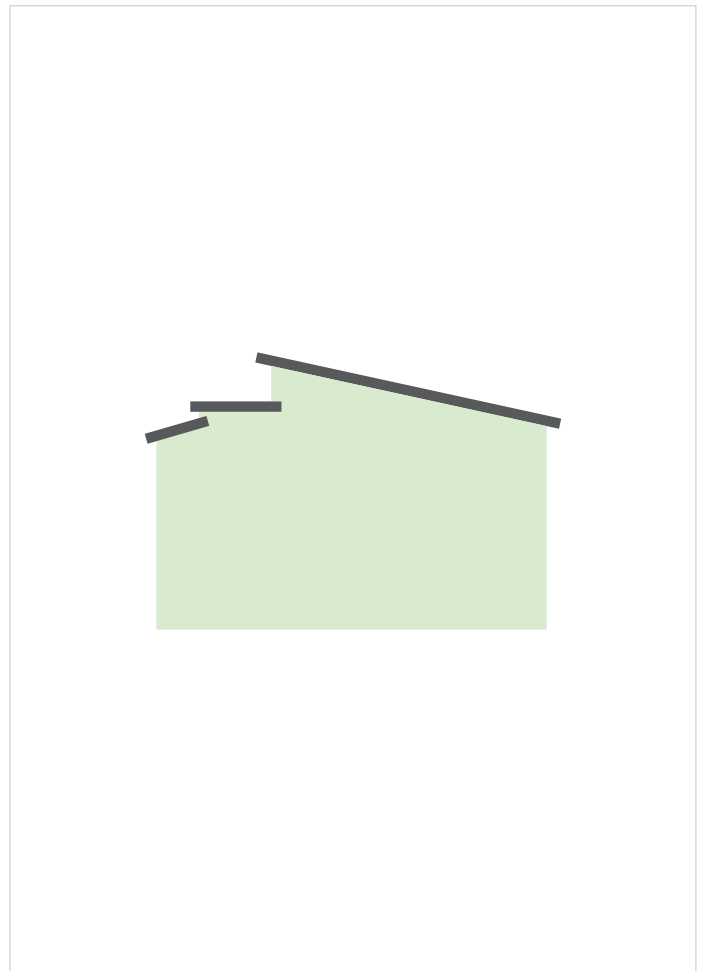
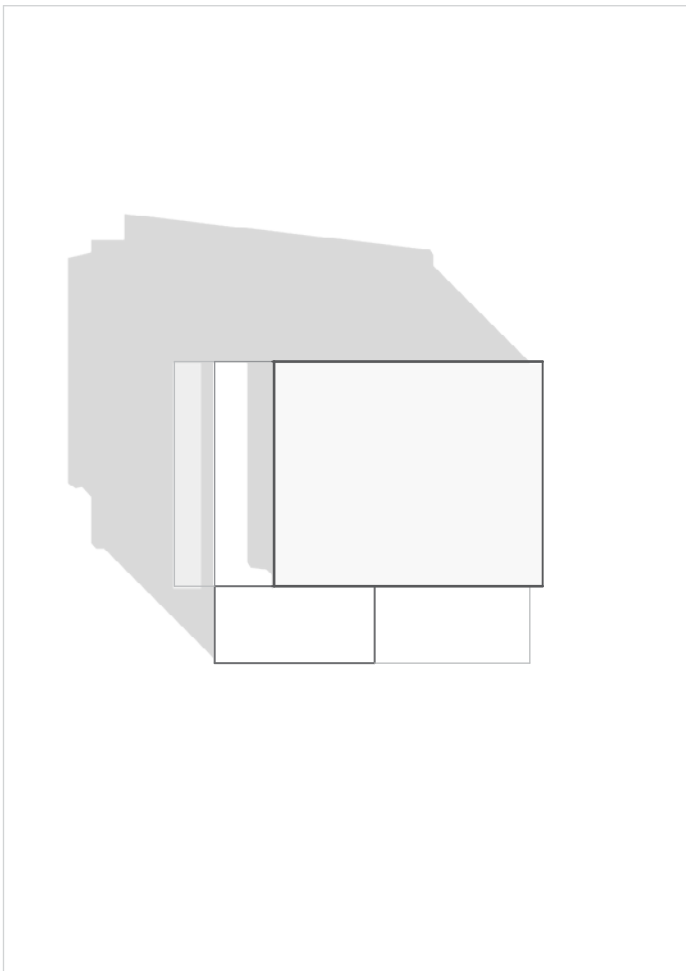
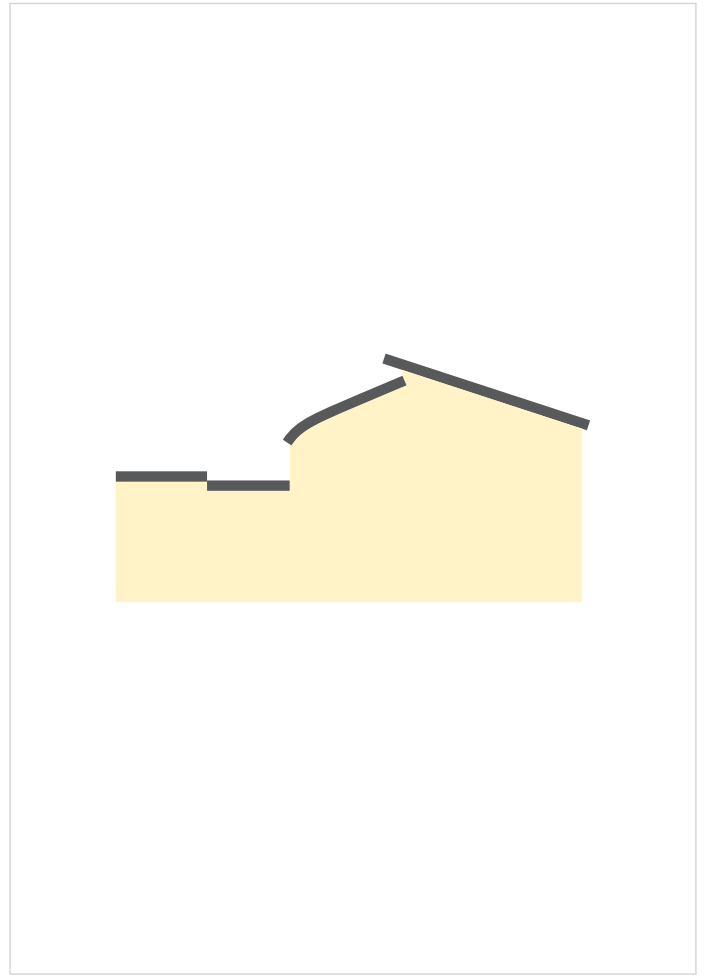
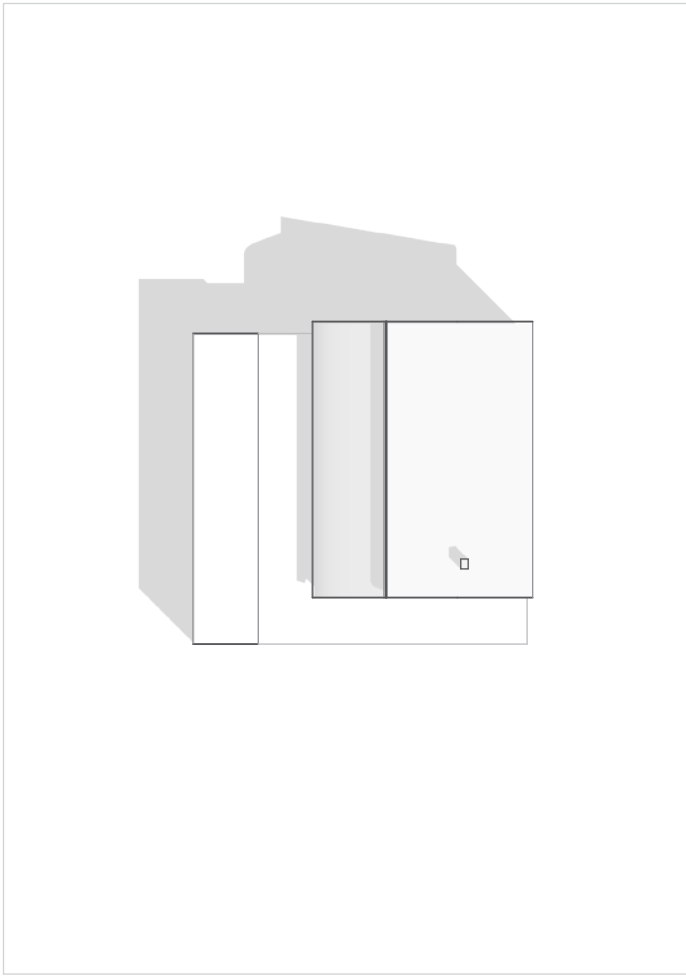

39.912509,18.248598
39.913165,18.246071

Roof Profiles

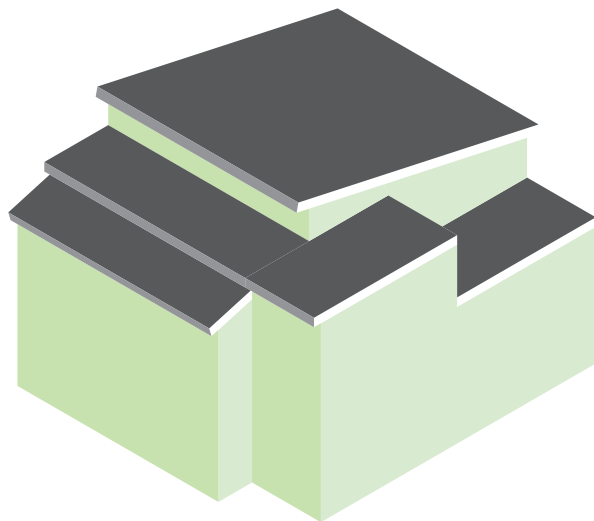
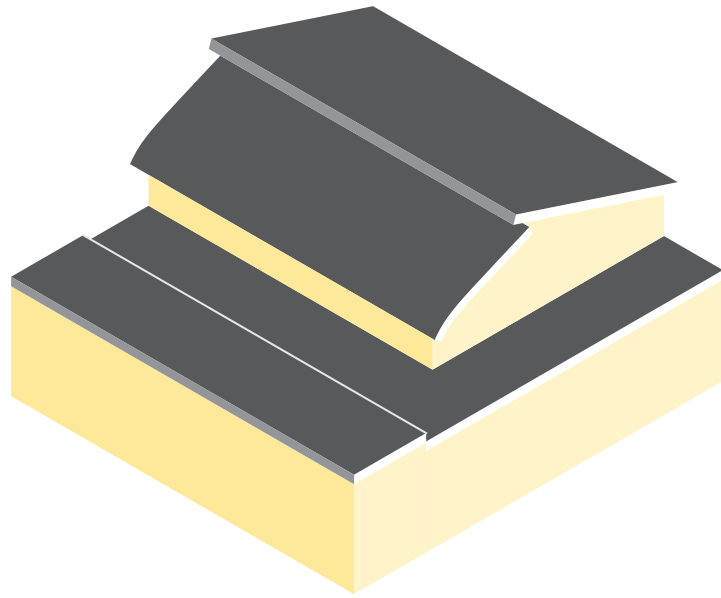

Roof Profiles

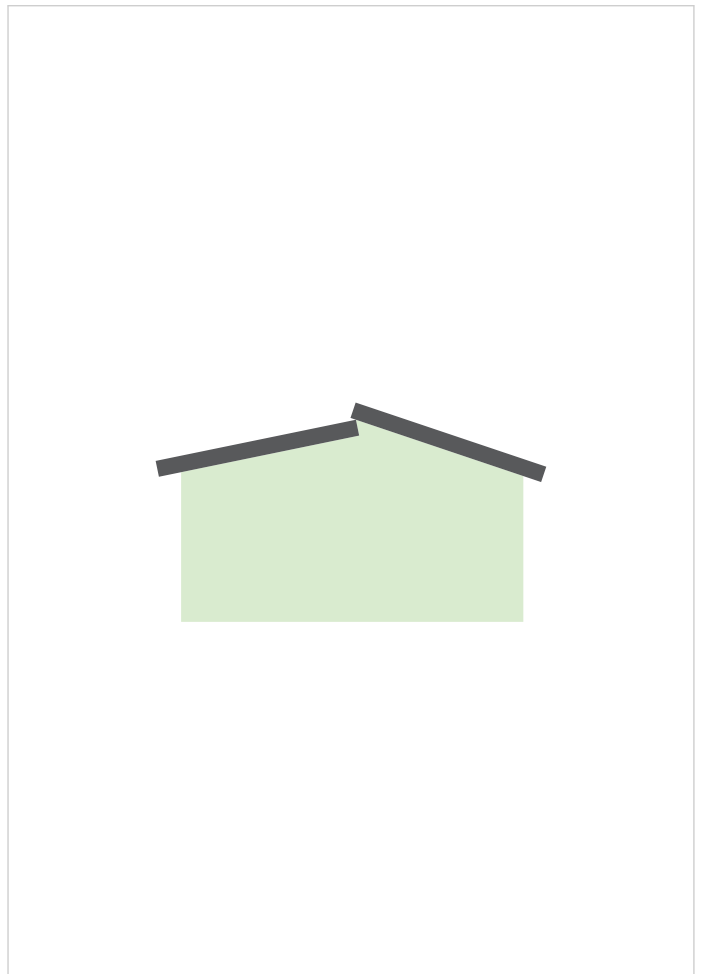
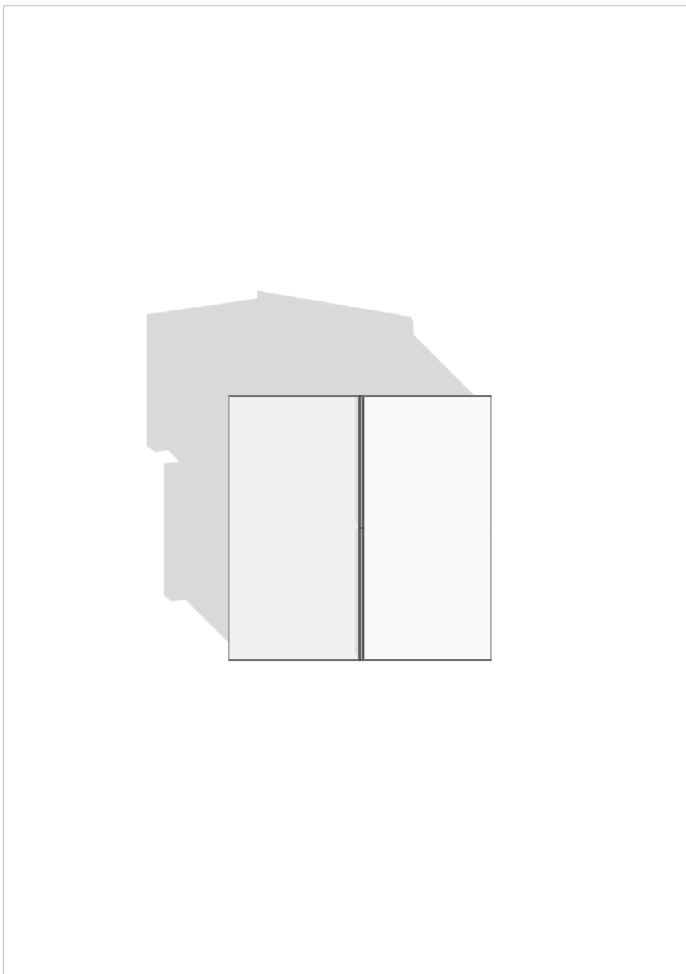
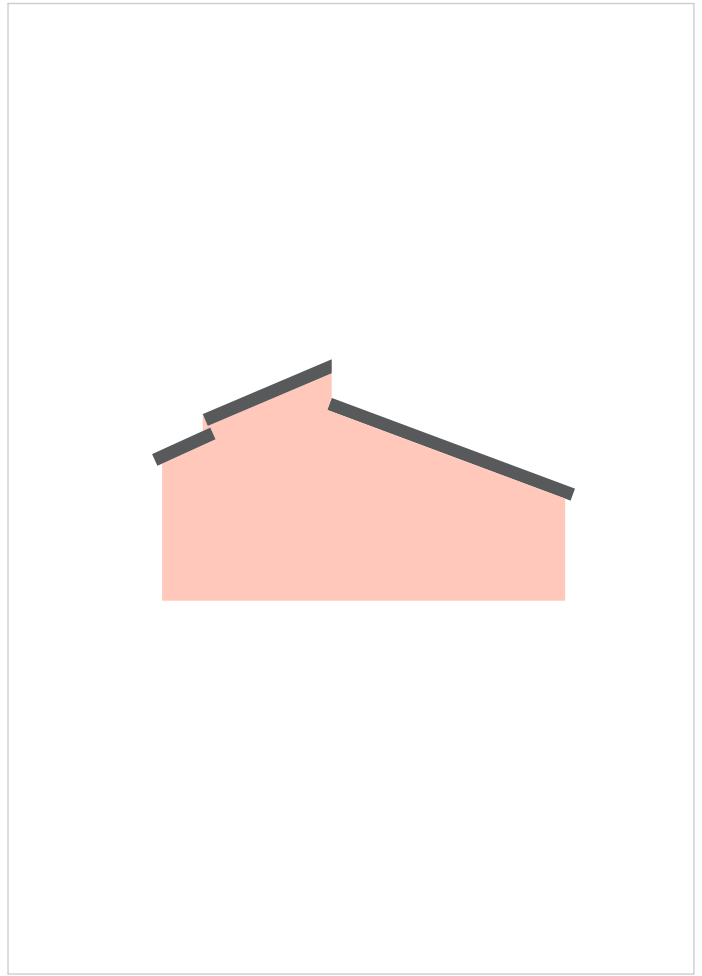
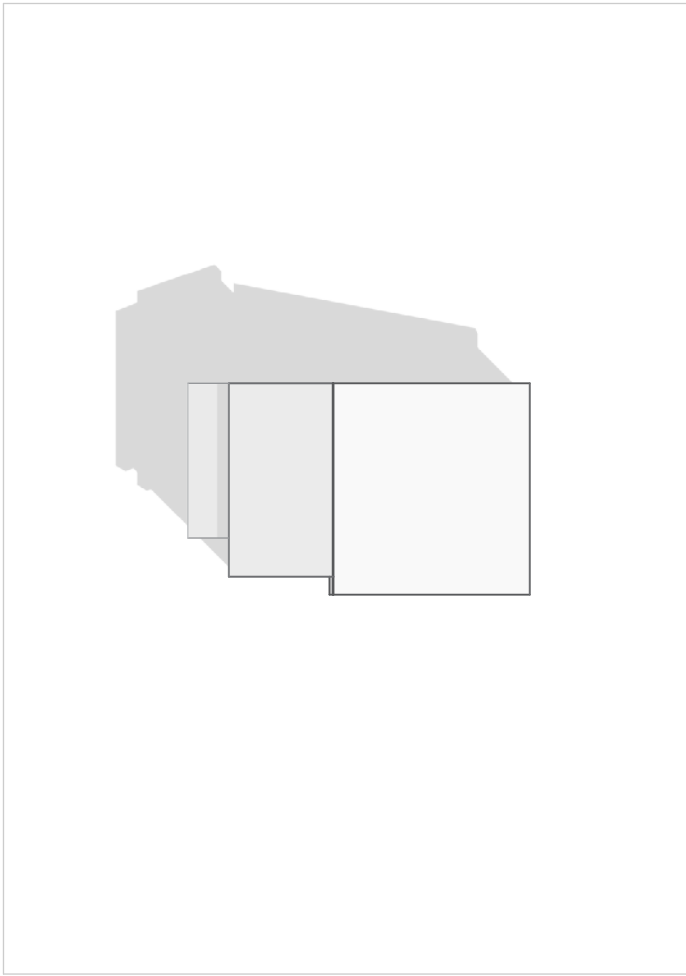

39.906895,18.246047
40.023567,18.144364

Roof Profiles

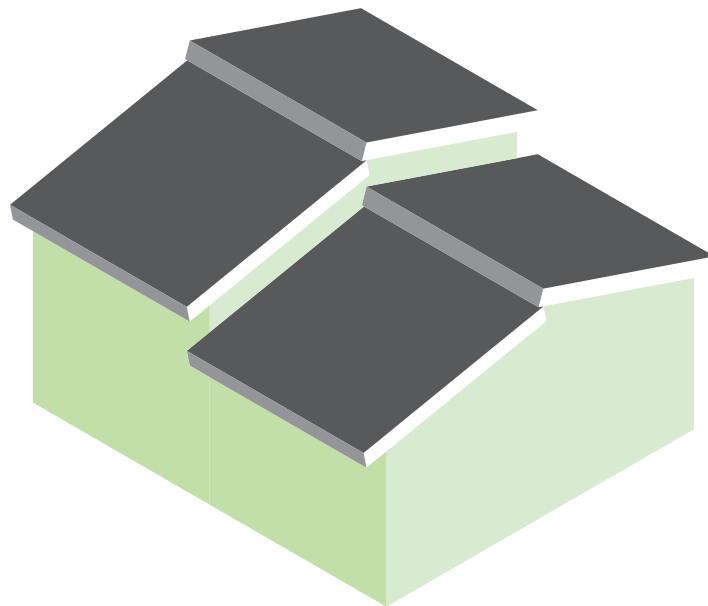
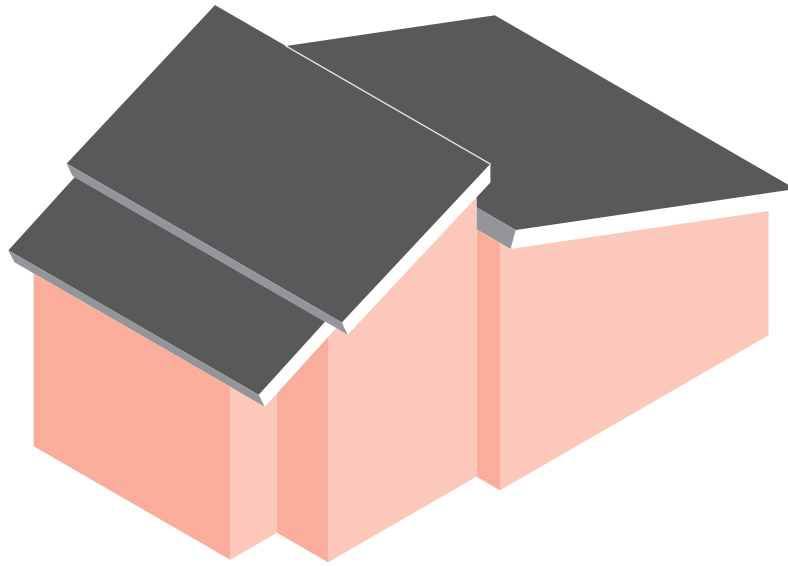

Roof Profiles

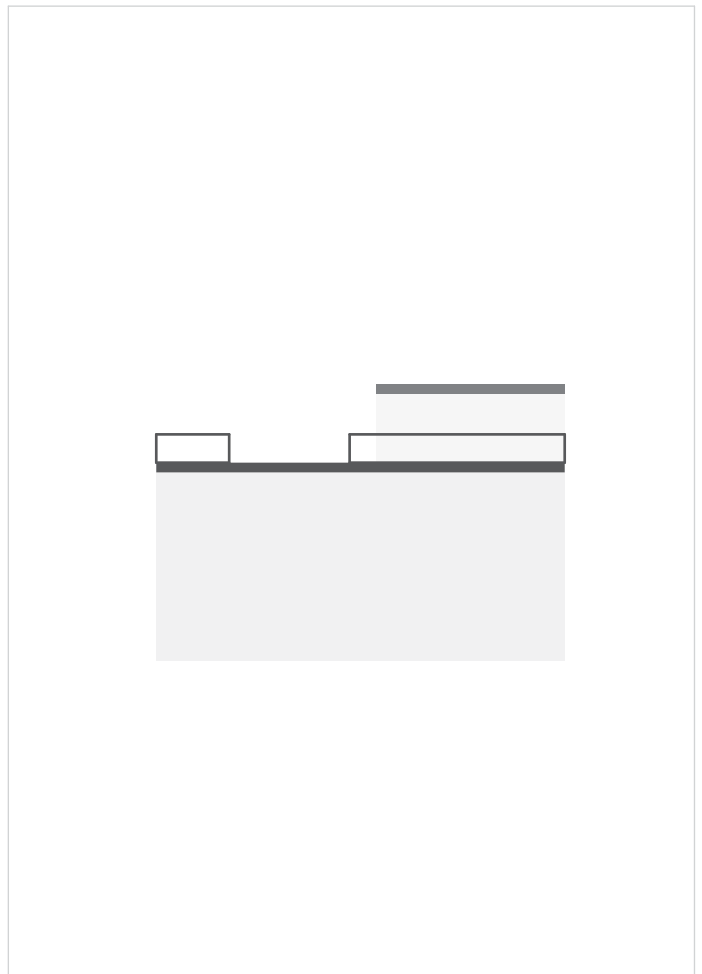
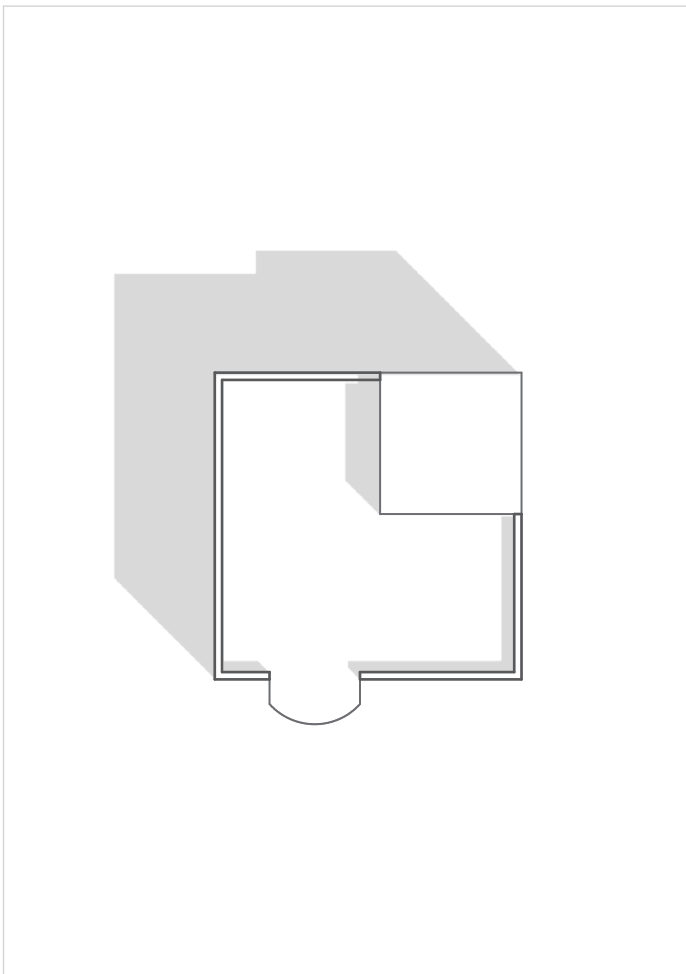
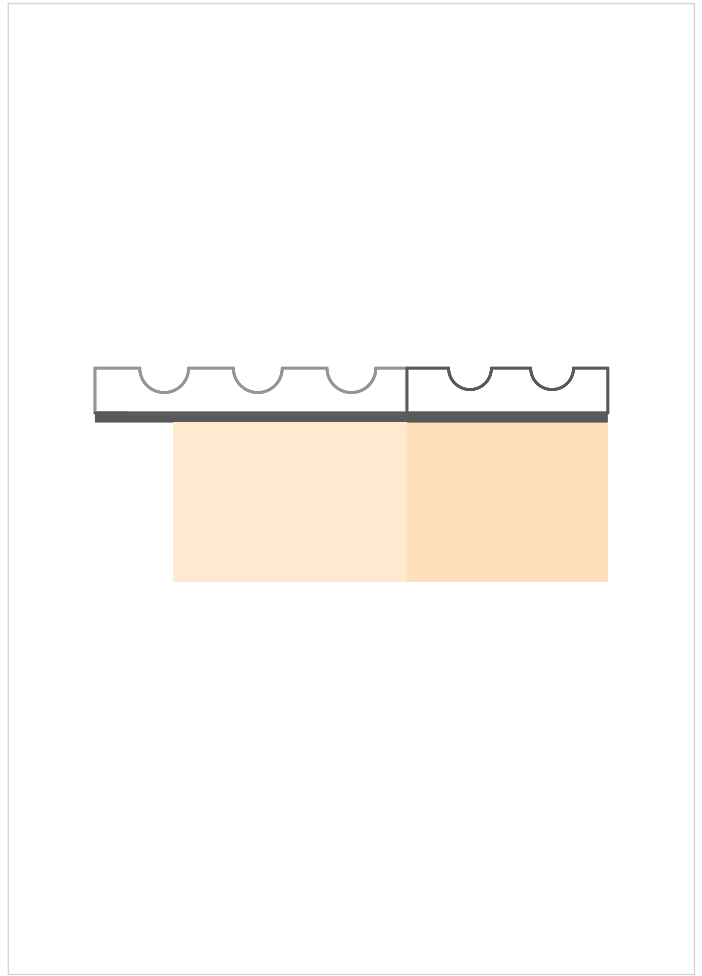
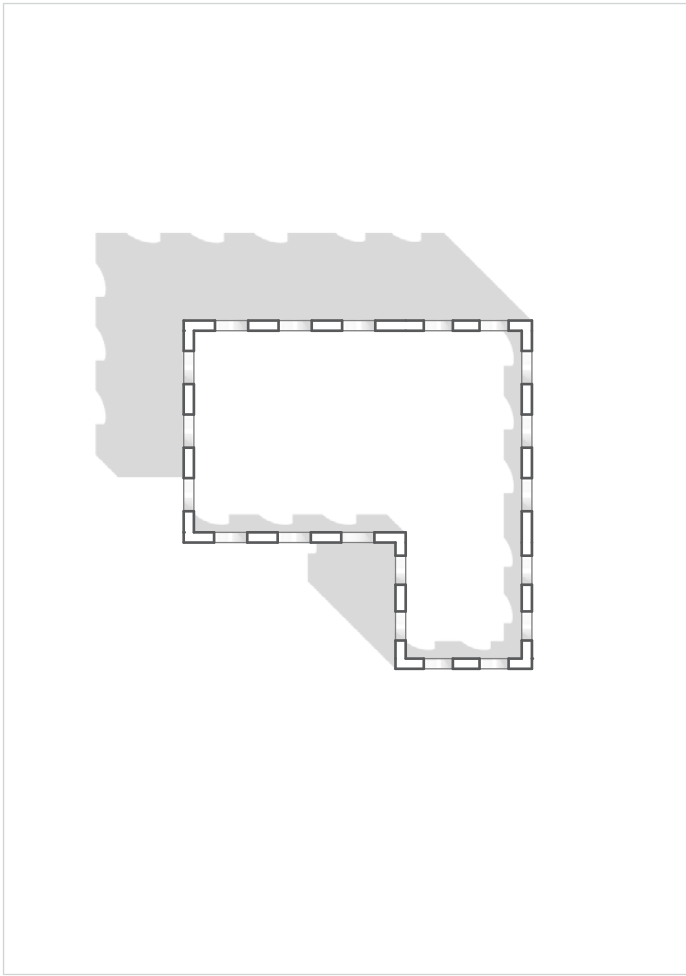

40.30277, 18.395419
39.86042, 18.300154

Roof Profiles

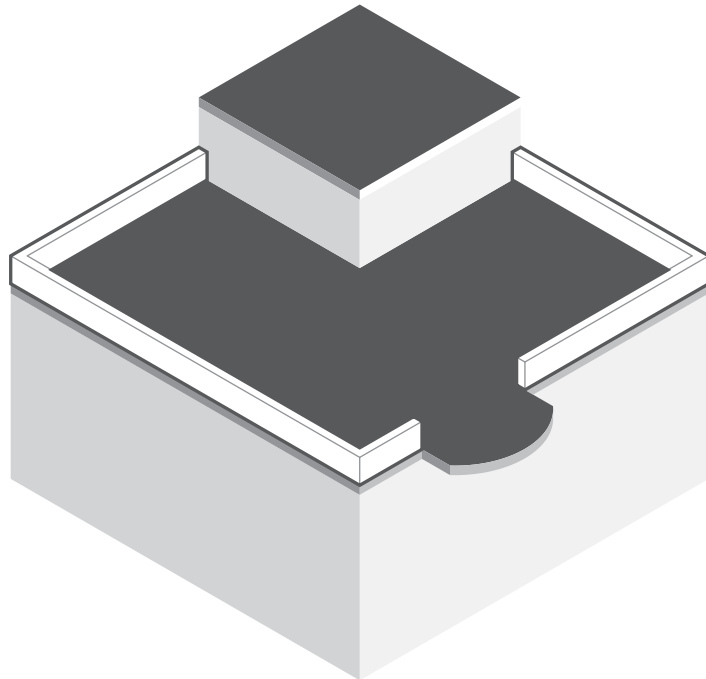
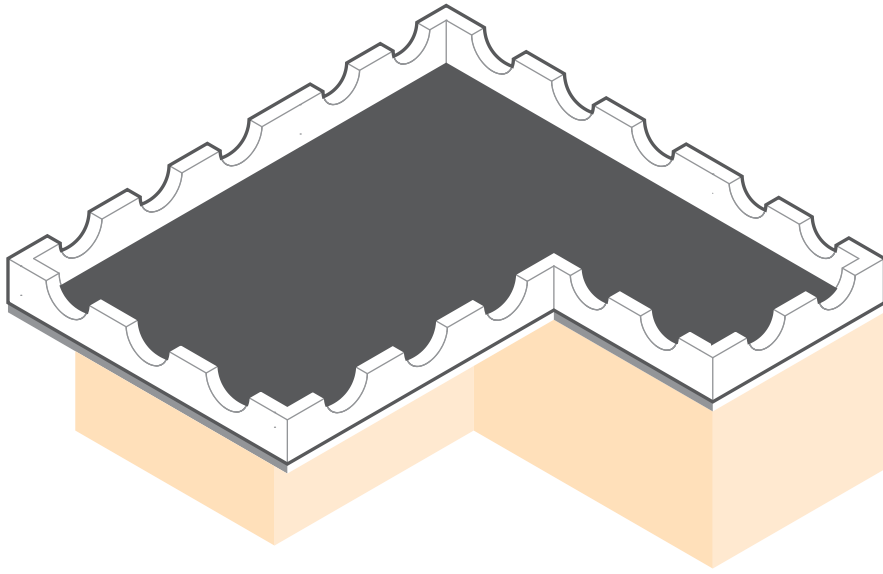

255

Roof Profiles

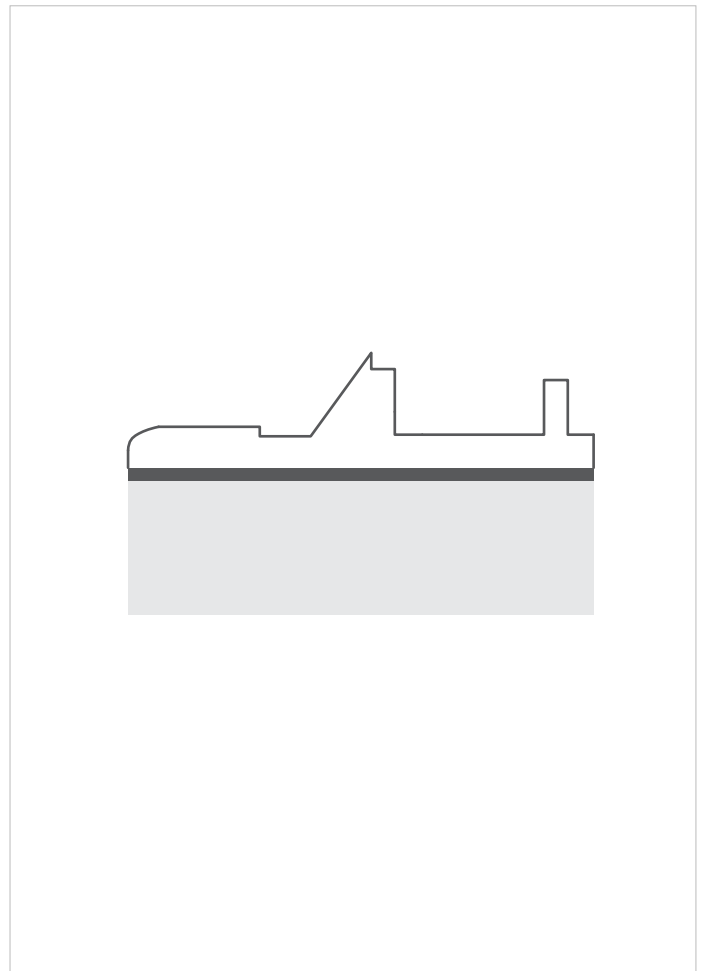
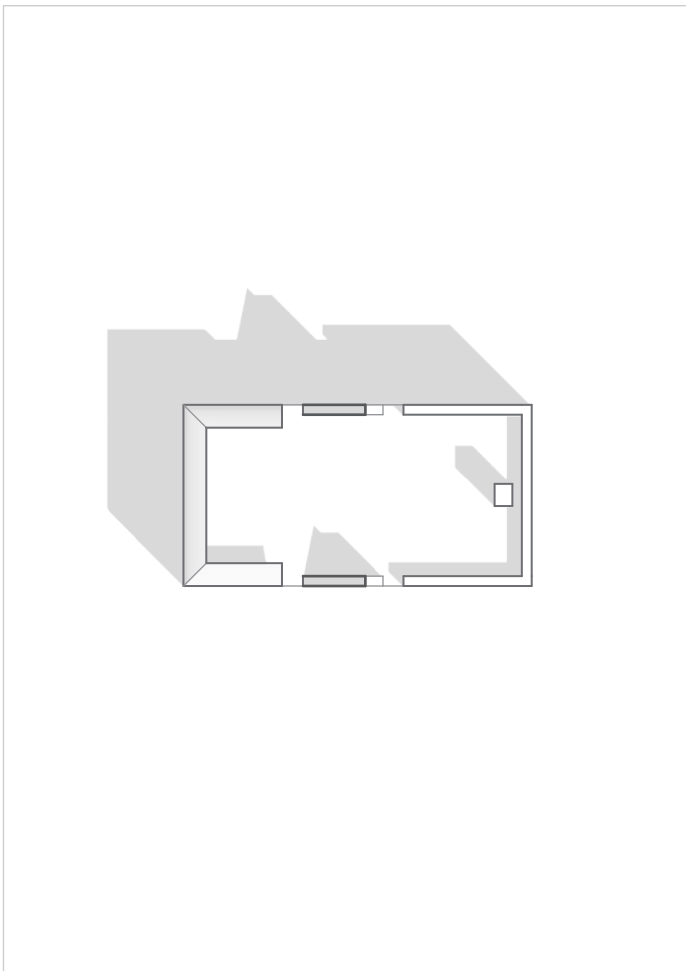
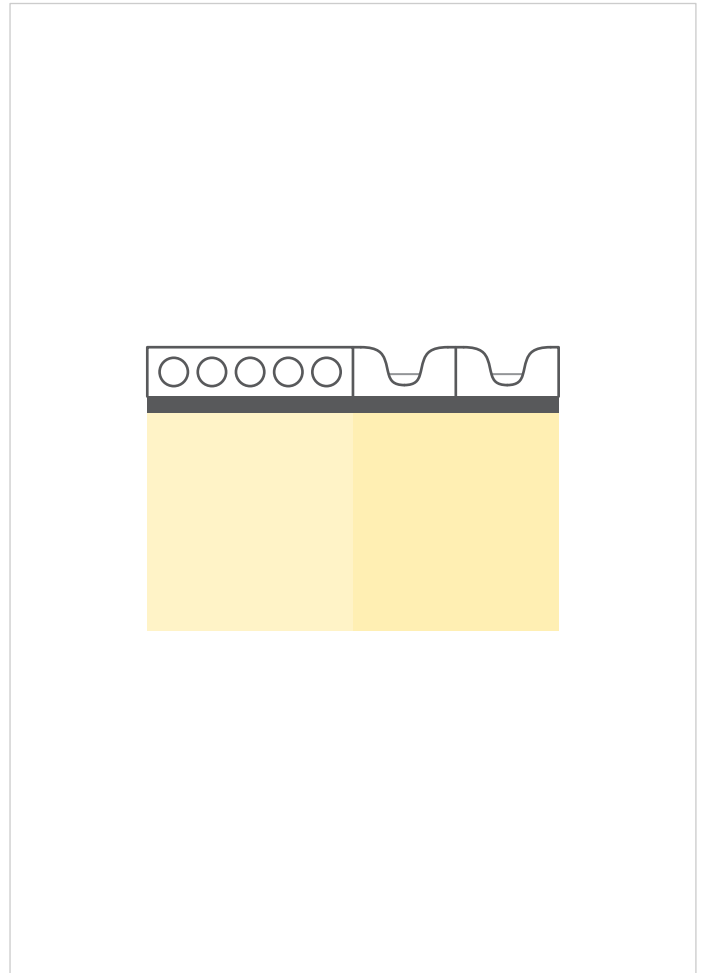
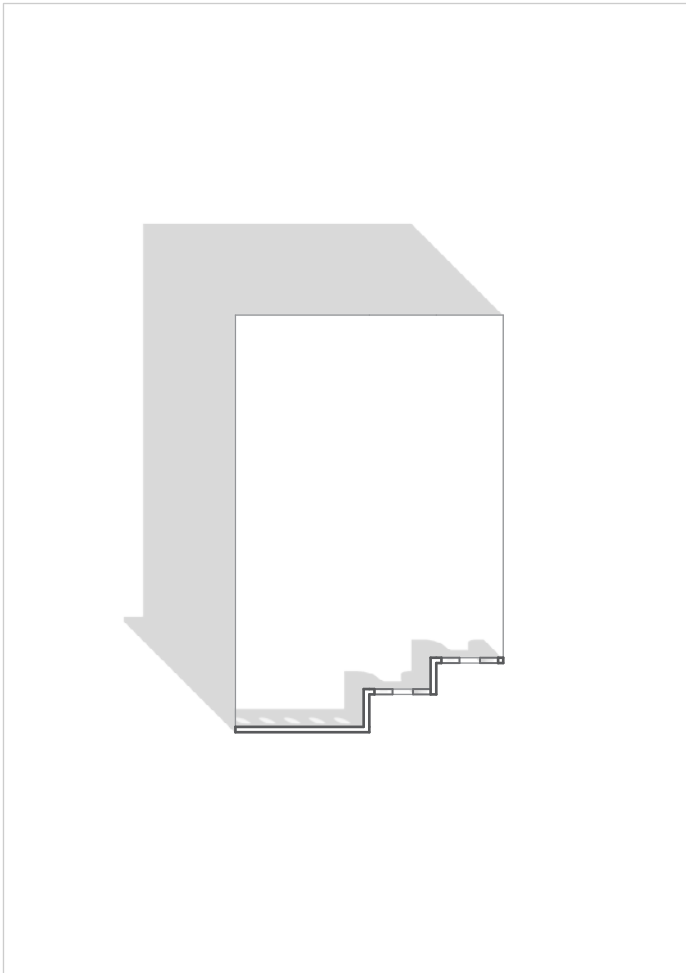

40.059718,18.054899
39.892811,18.328331

Roof Profiles

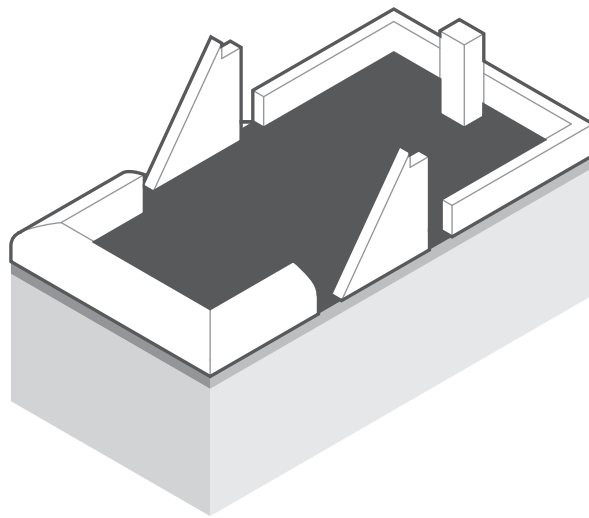
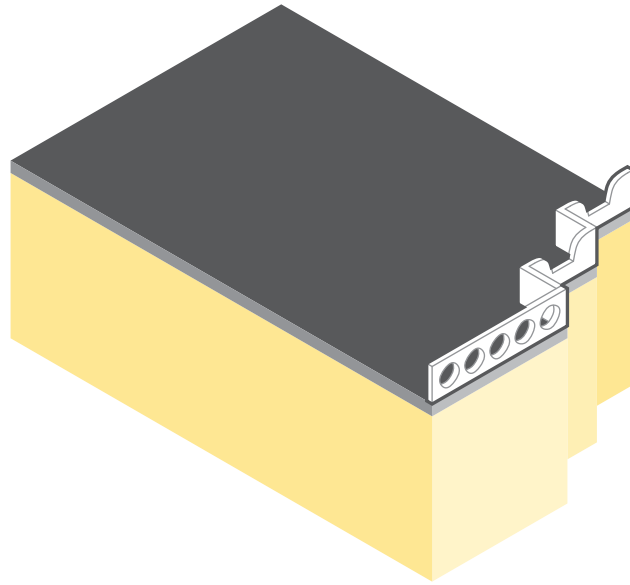

Roof Profiles

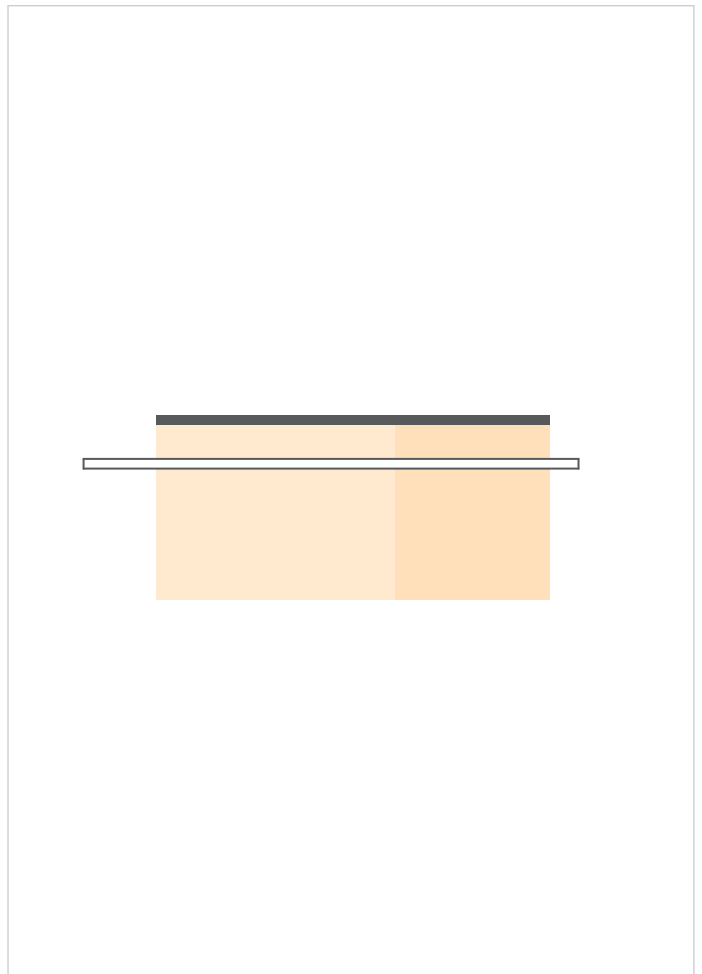
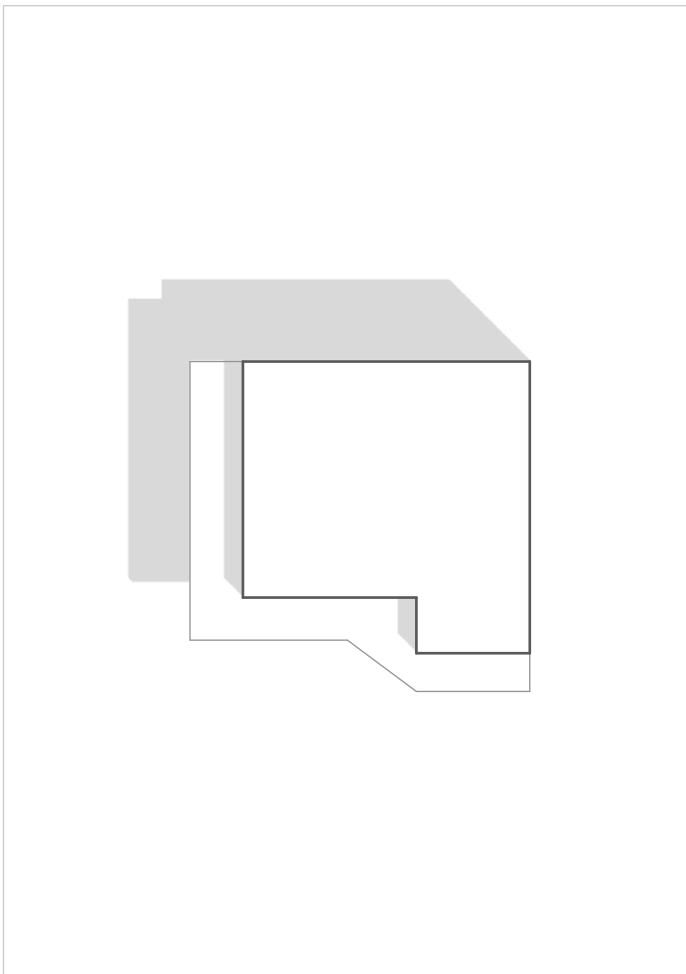
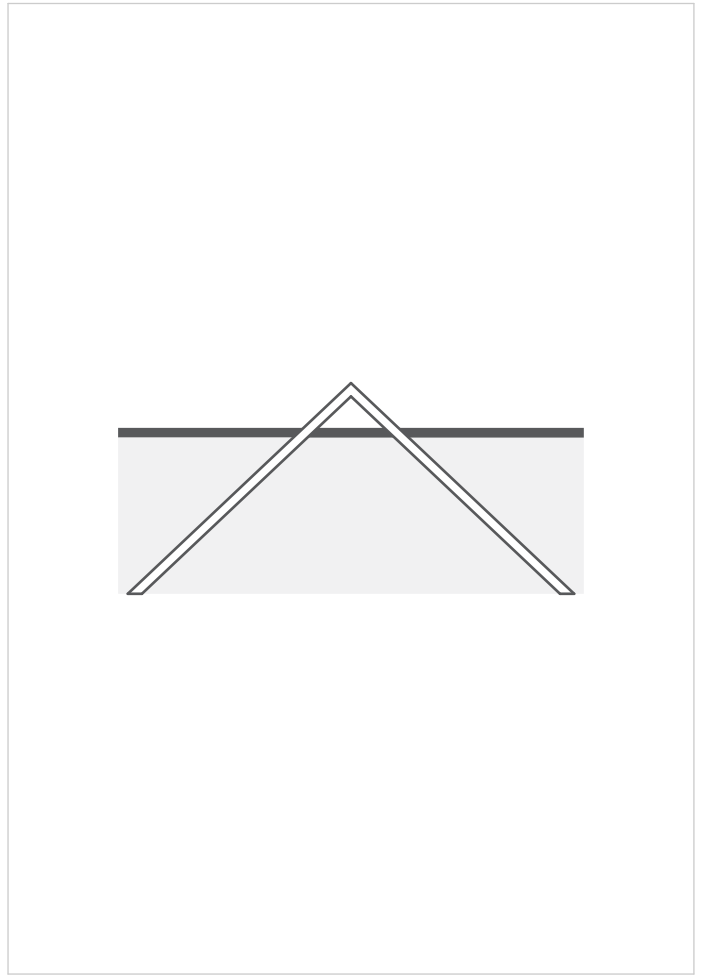
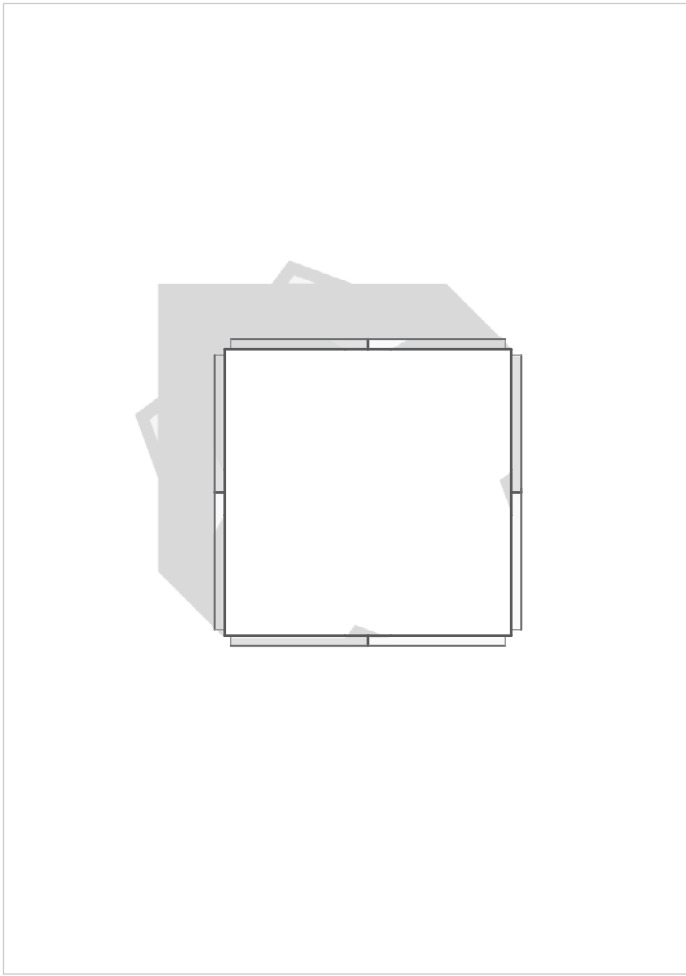

Roof Profiles

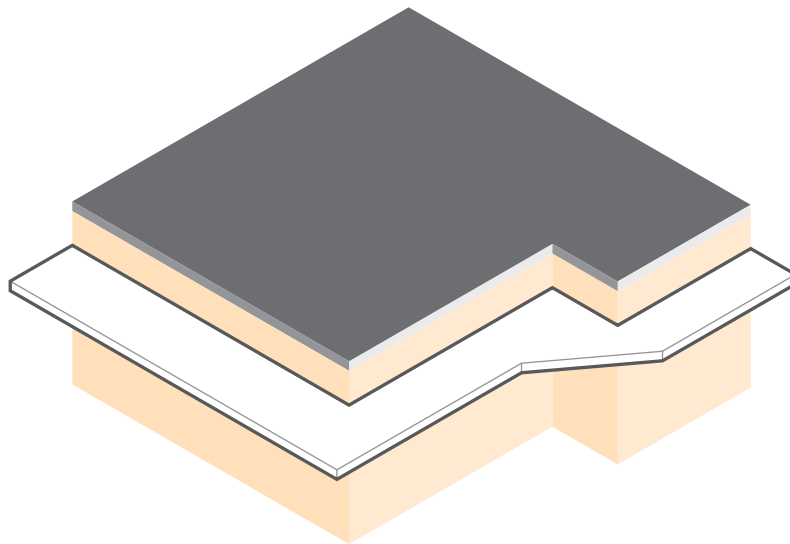
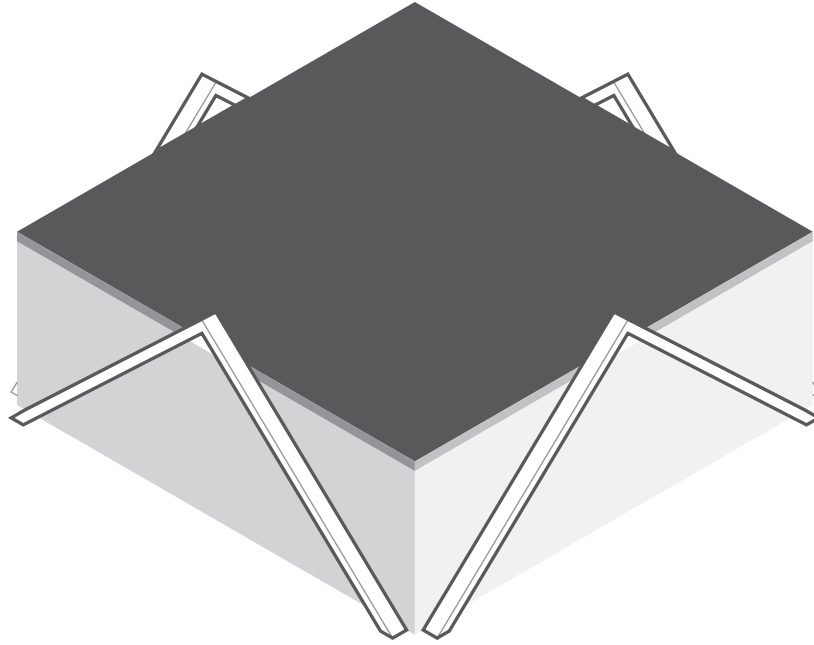

Roof Profiles

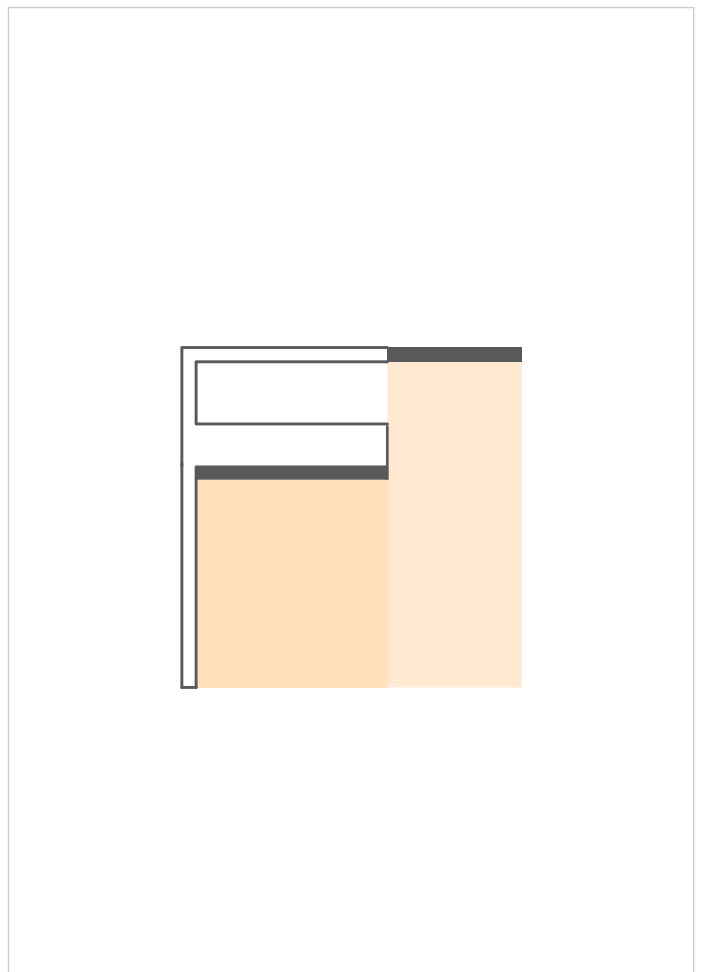
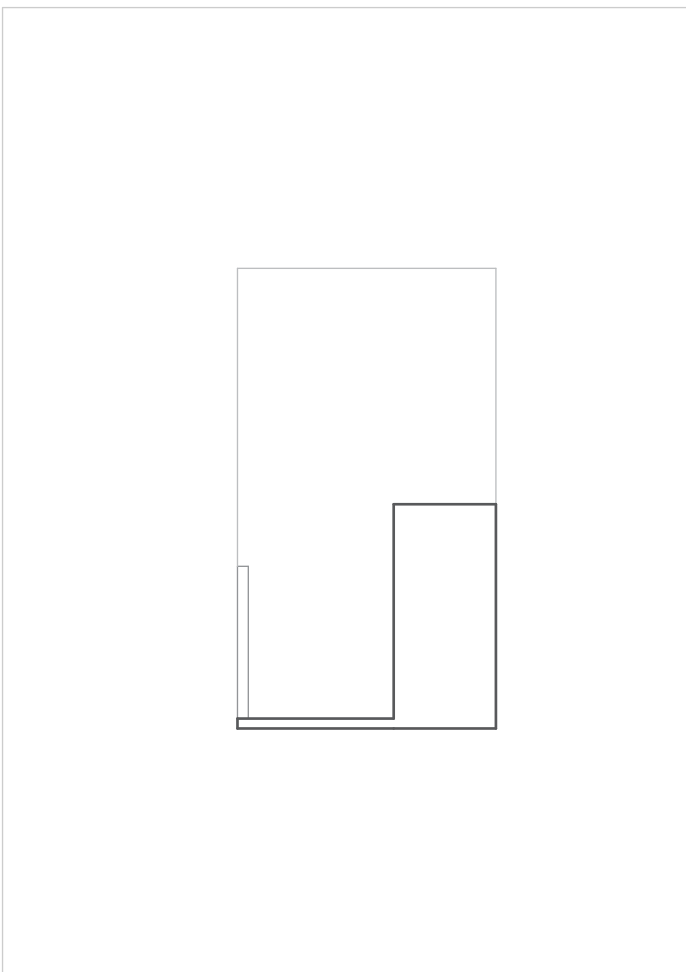
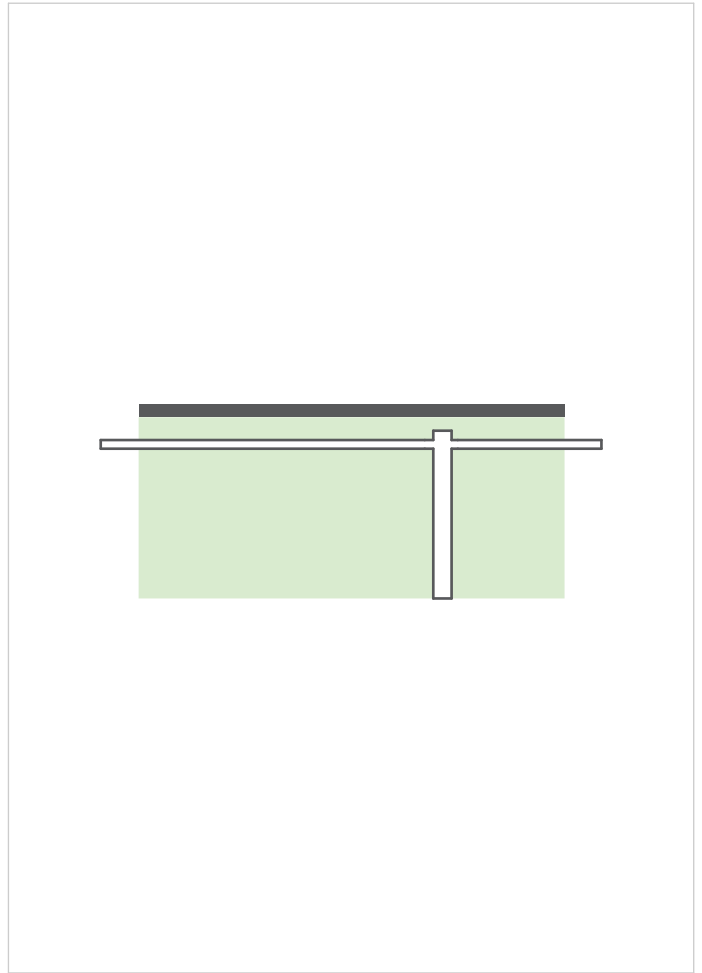
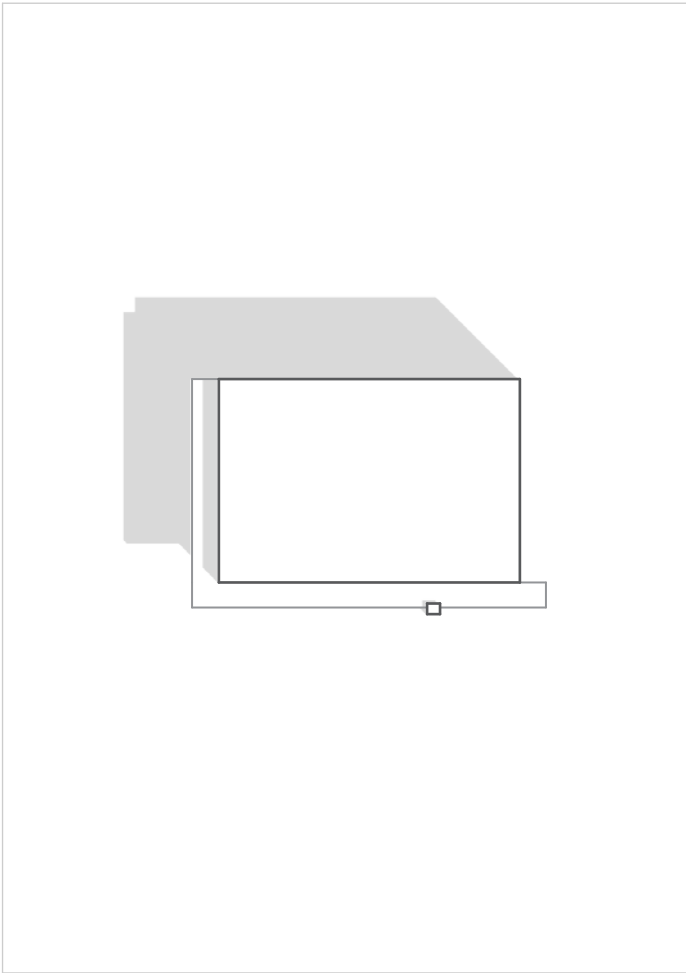

40.333955,18.298866
40.059972,18.051919

Roof Profiles

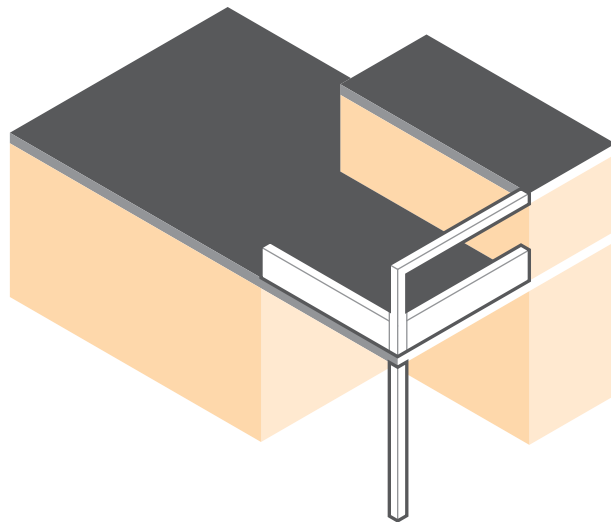
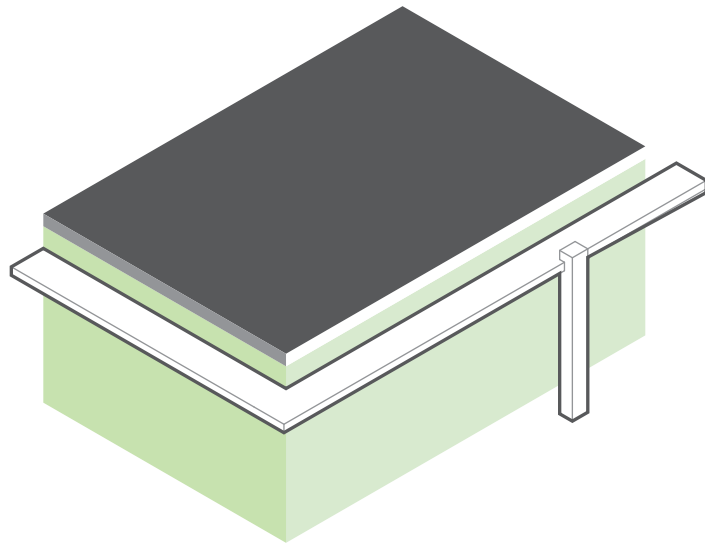

Roof Profiles

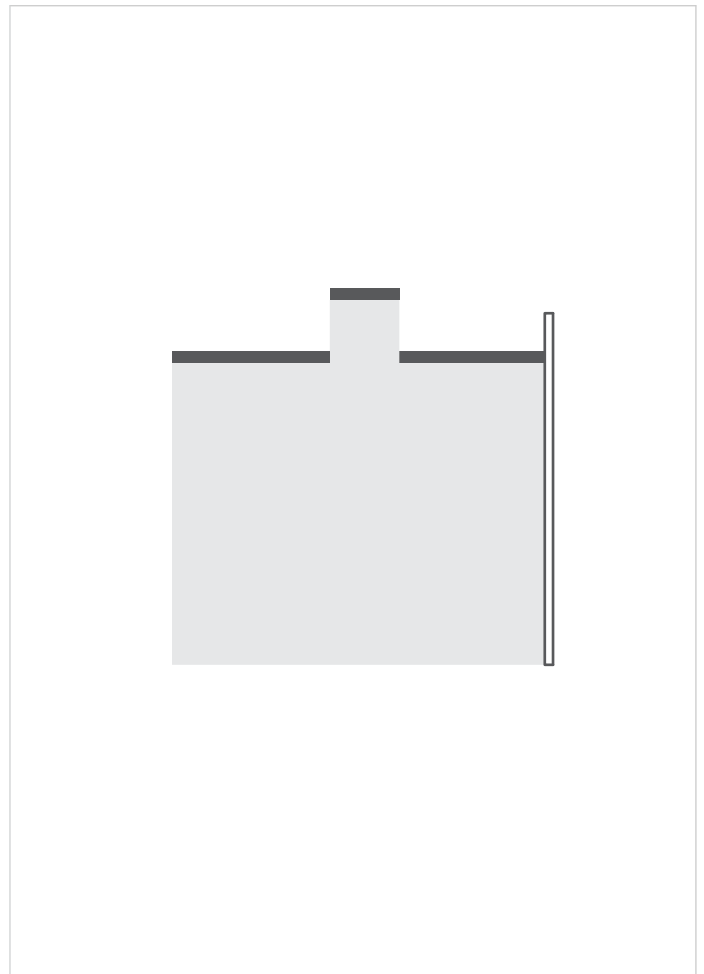
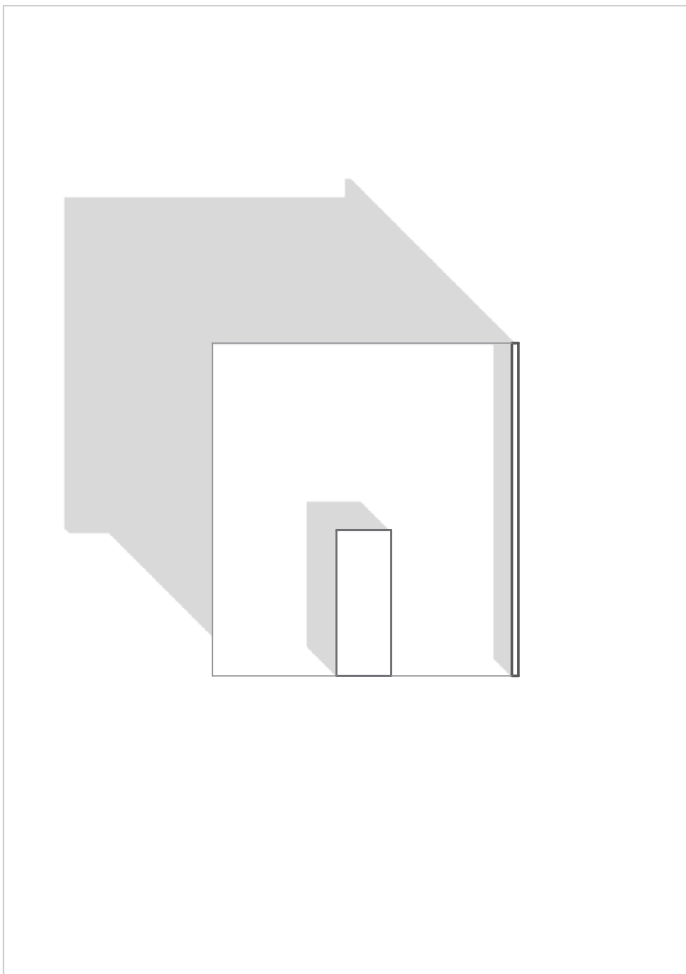
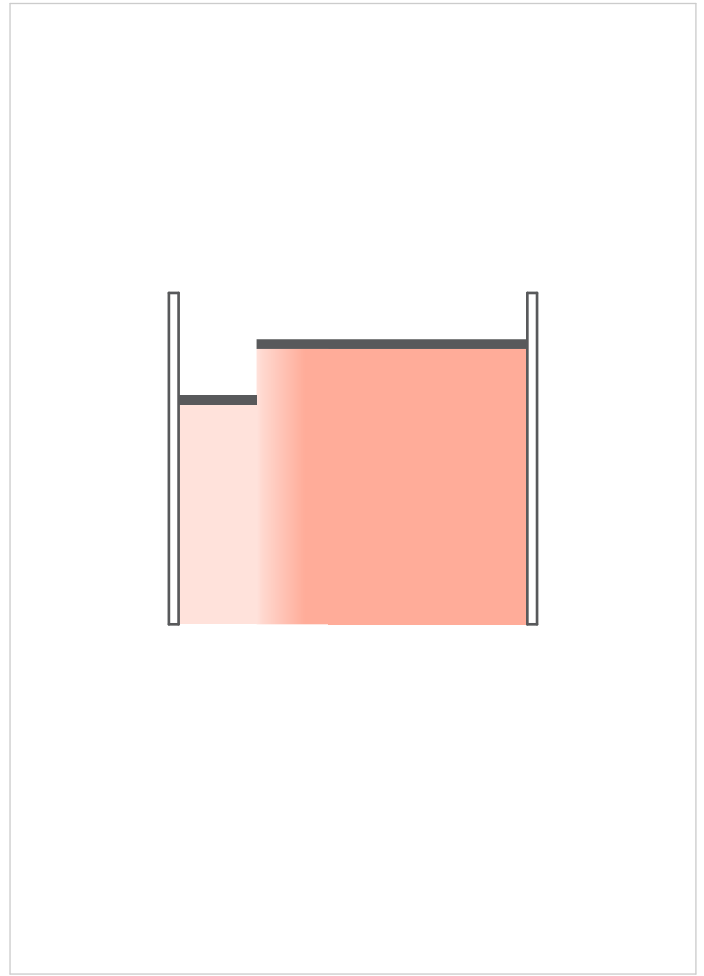
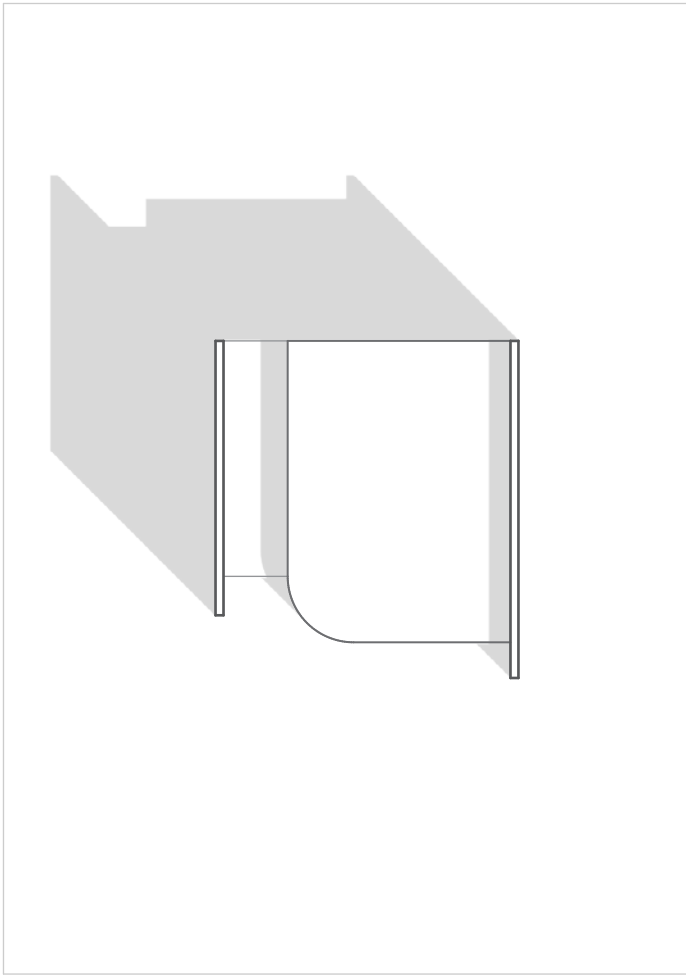

39.833237, 18.353422
40.336045, 18.298148

Roof Profiles

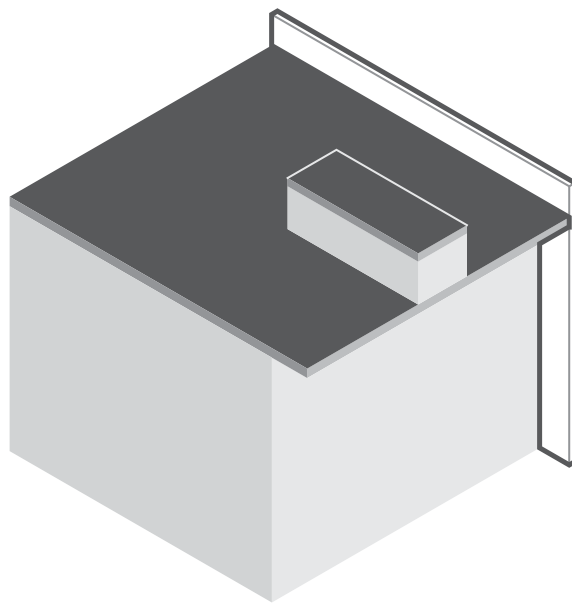
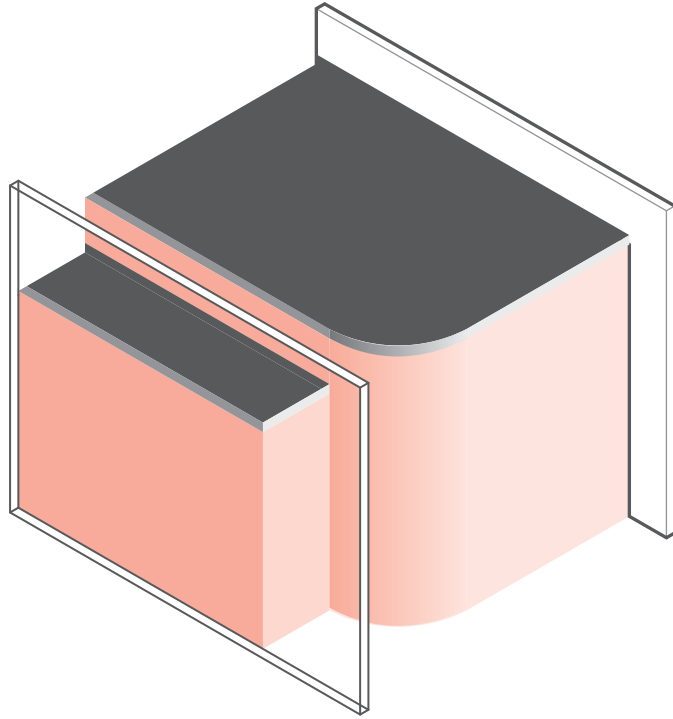

Roof Profiles

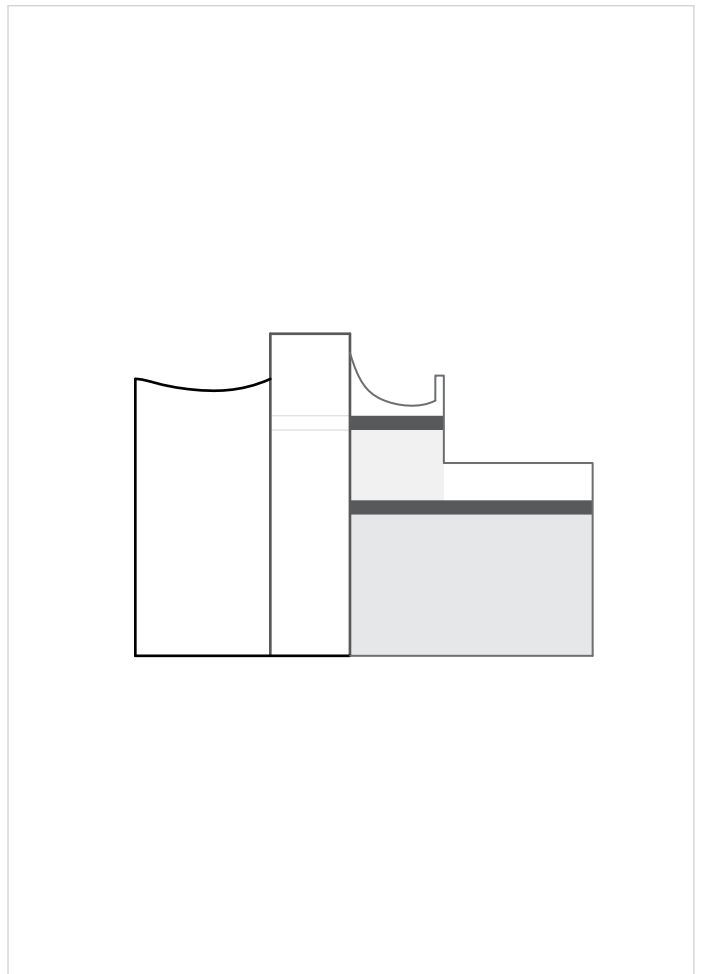
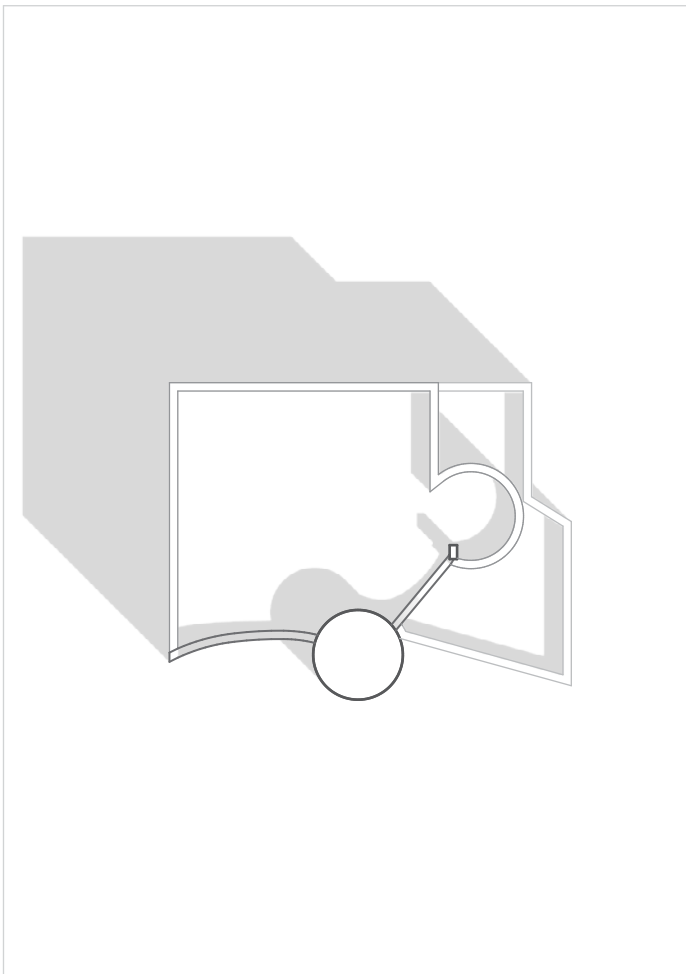
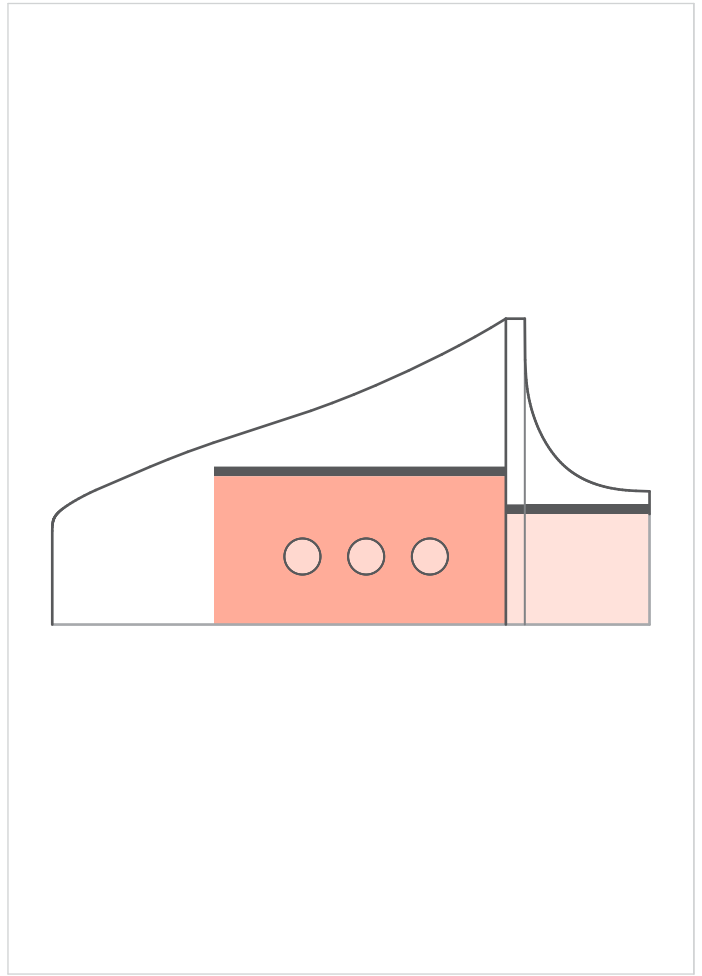
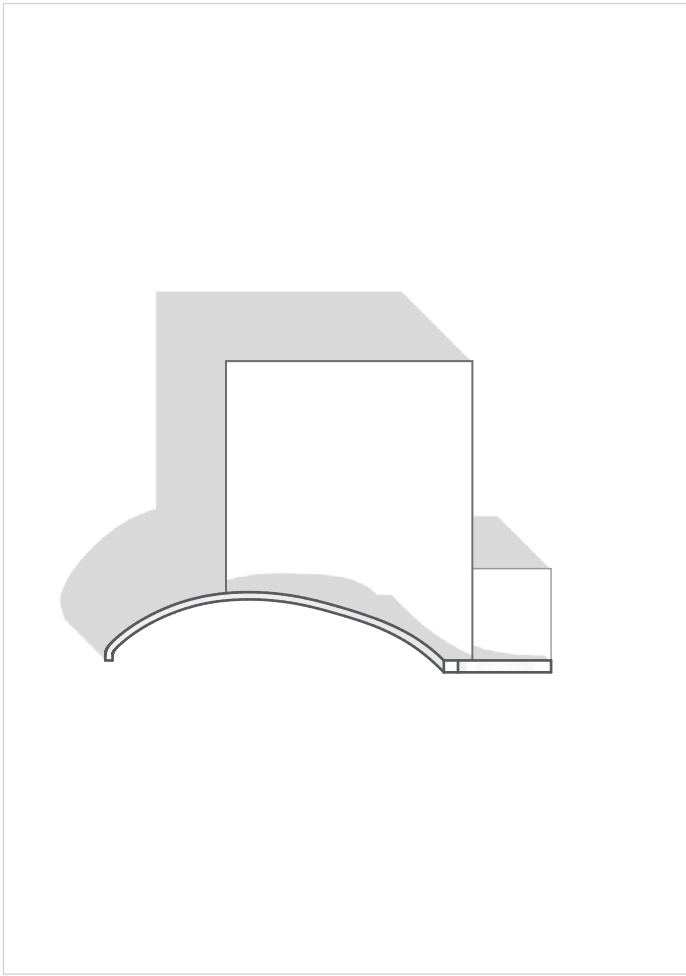

39.856097,18.301683
39.958701,18.363915

Roof Profiles

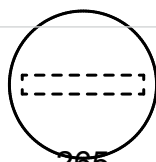
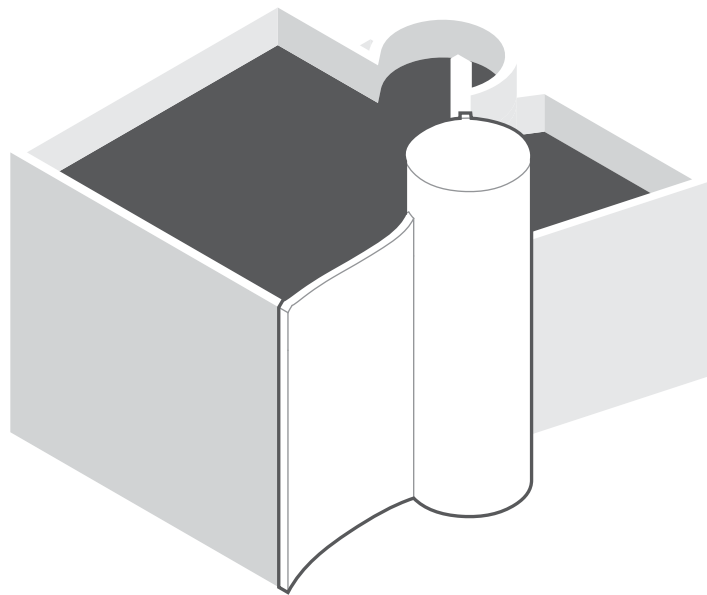
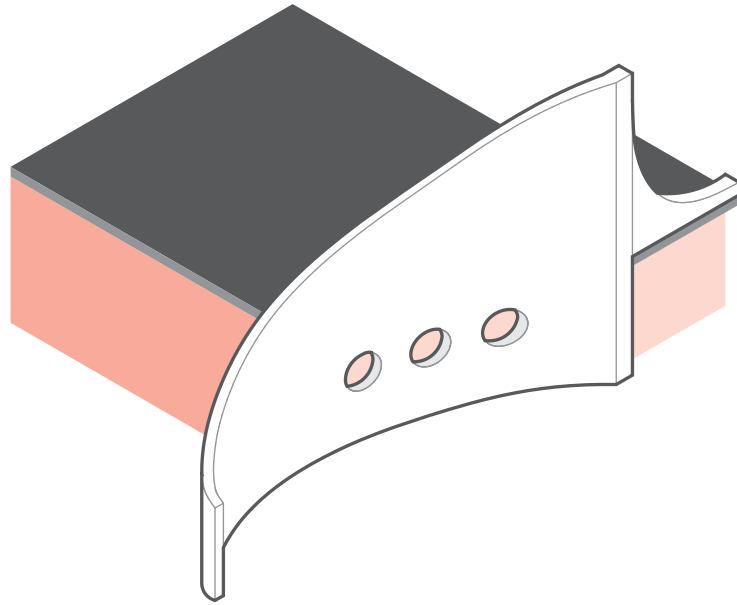

Doors

Daniel Prendergast, Nicholas
Wahler

Doors



Doors

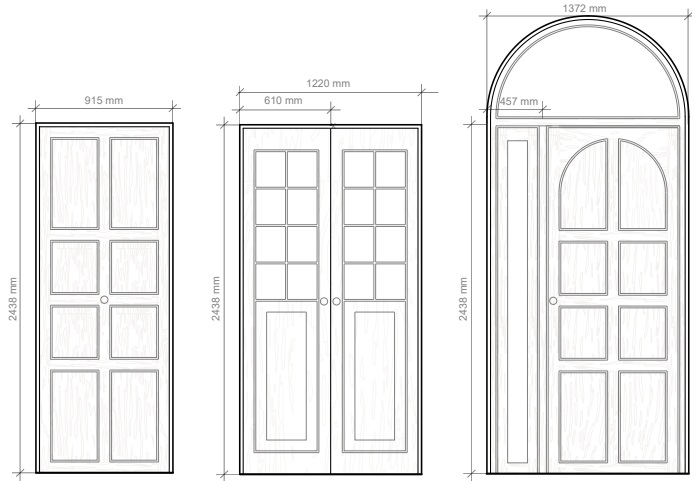
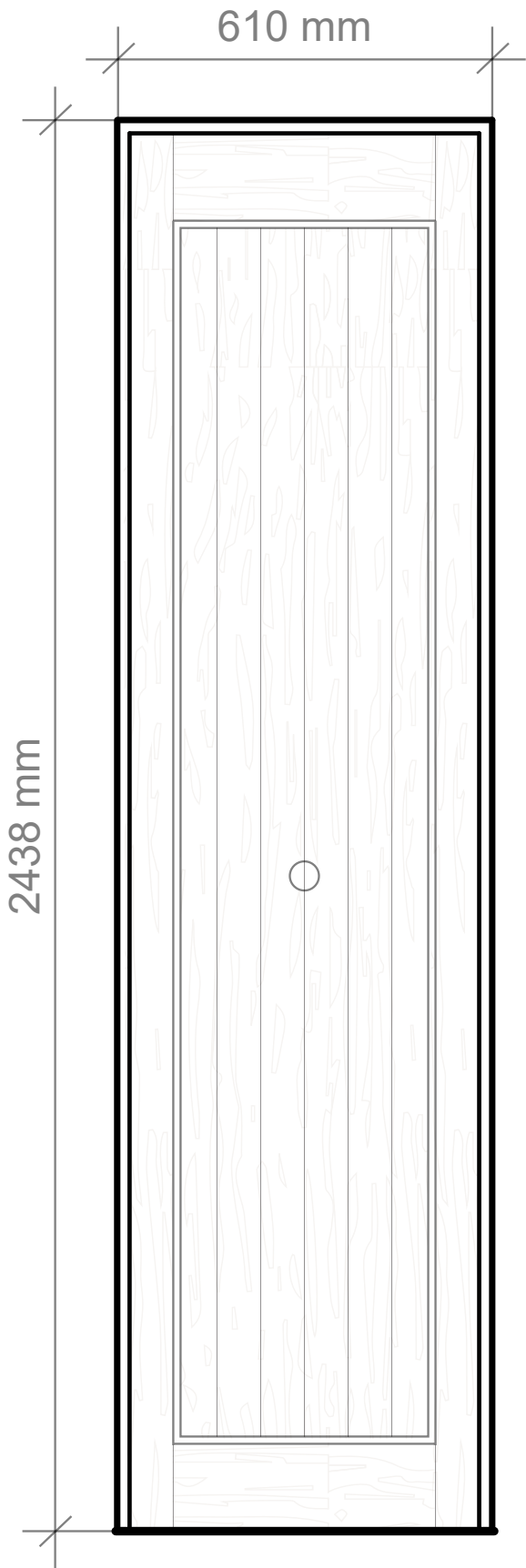

generic groceries
[162,133,111]



bad intentions
[159,90,57]

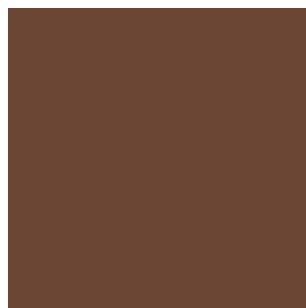

fallen gelato
[108,70,52]

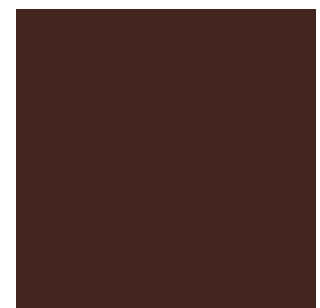

moody mom
[67,37,31]

legname

Doors

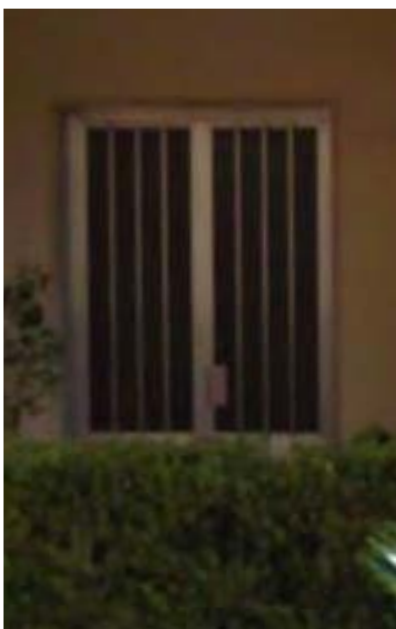

Doors

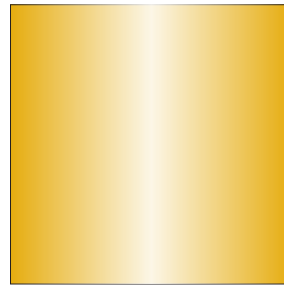
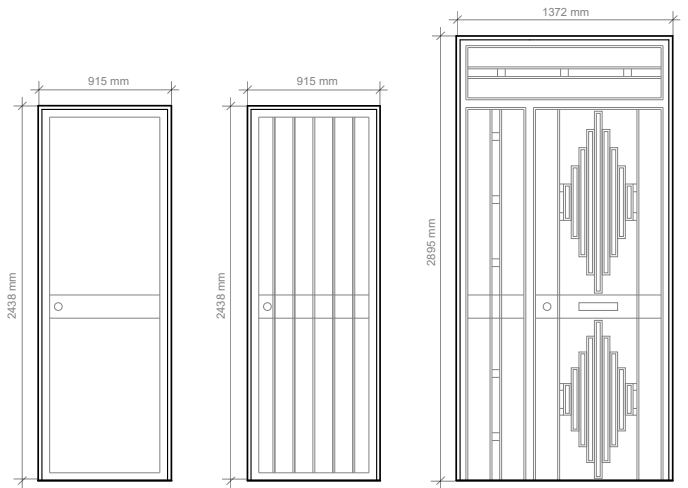
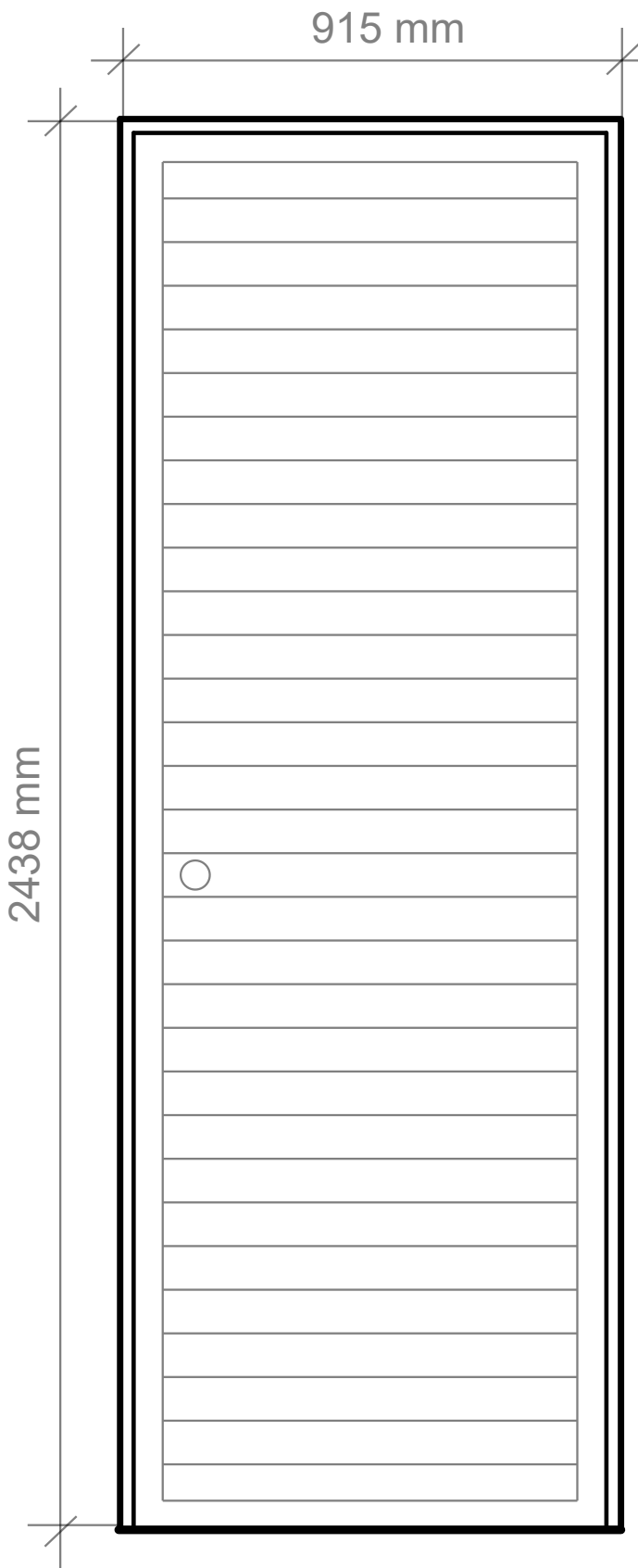

gold

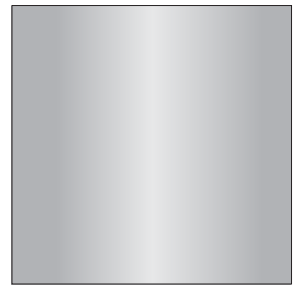

chrome

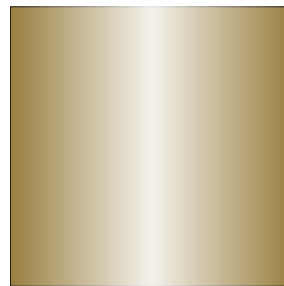

brass

mescolanza

Doors

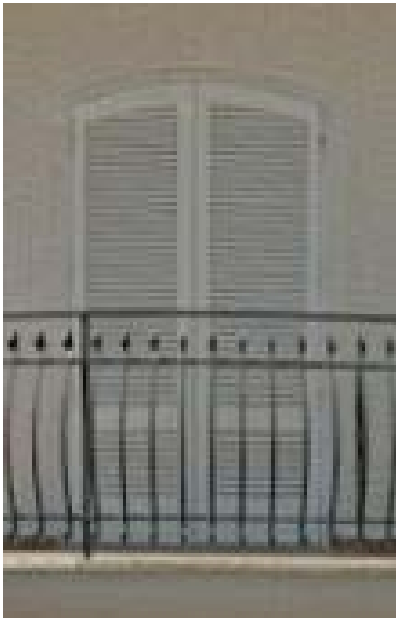

Doors

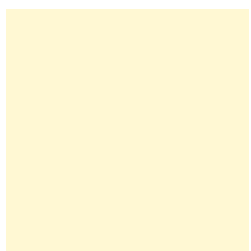
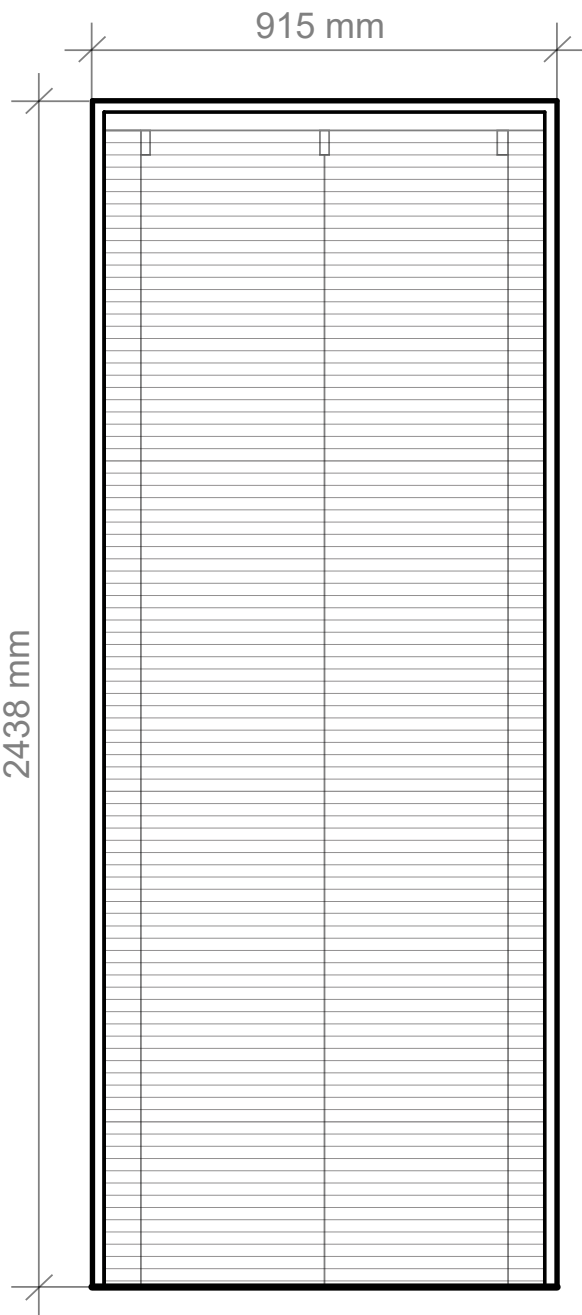
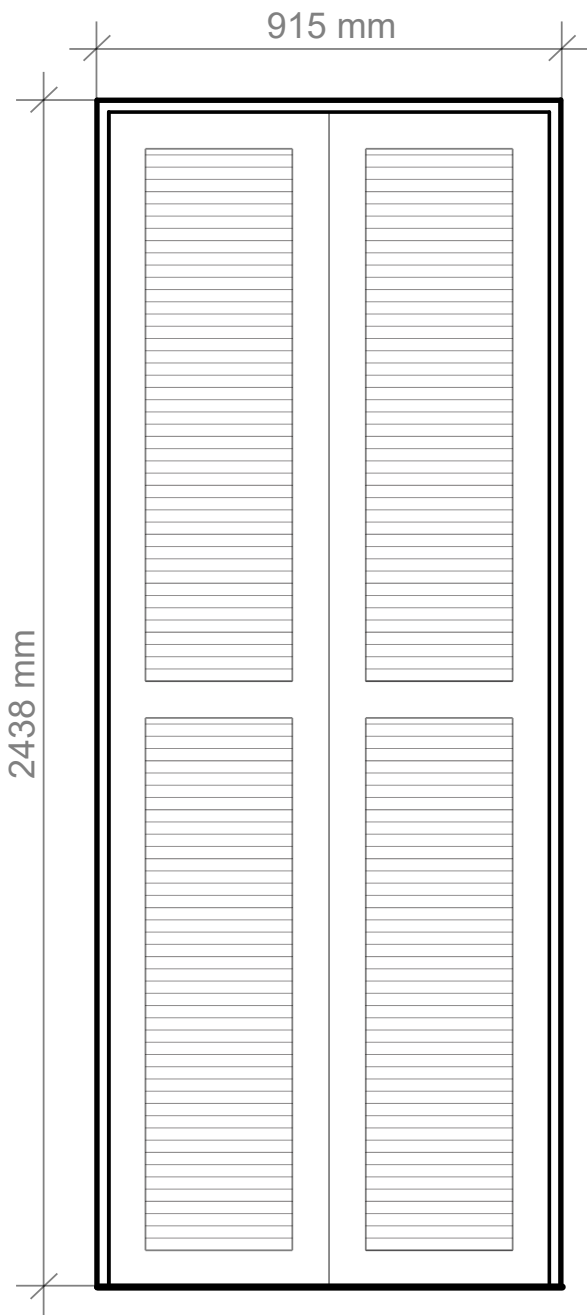

kale salad
[255,248,212]



recycled bacardi
[182,62,34]



personality deficit
[246,232,128]



poseidon's hot tub
[81,119,111]

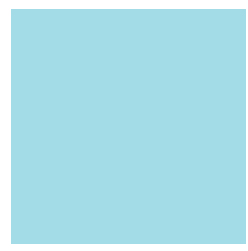

walking on sunshine
[142,255,255]



the green mile
[100,114,49]

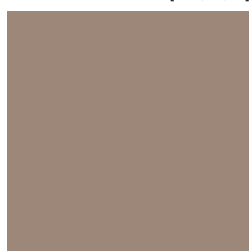

dead coral reef
[120,100,100]

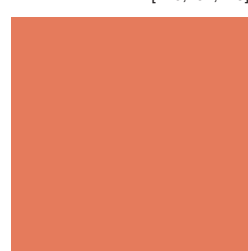

fire escape



morning spritz
[100,100,100]



bedside toy

serranda

Doors

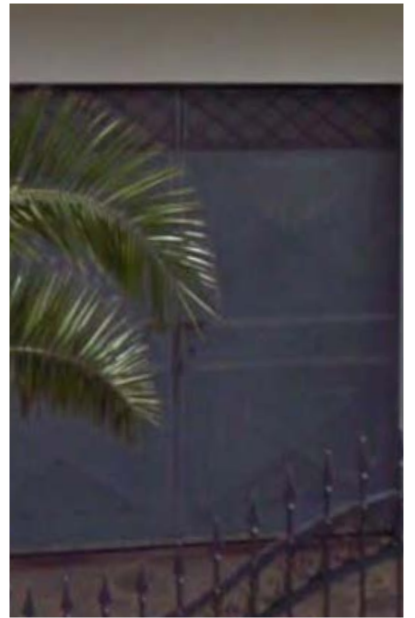

Doors

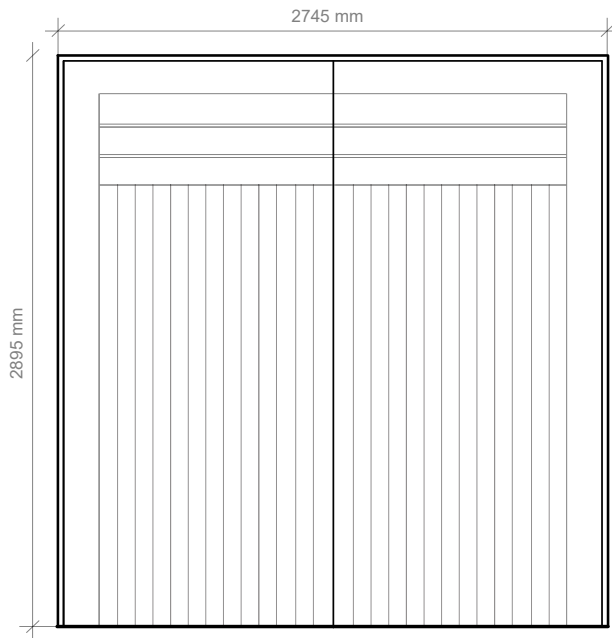
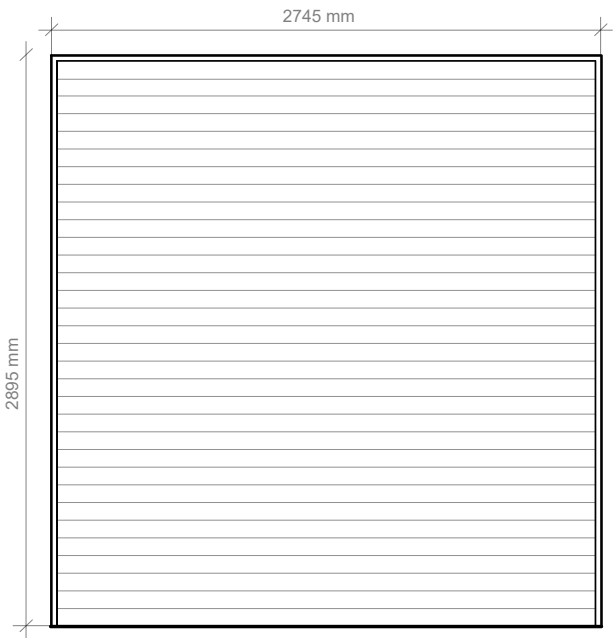
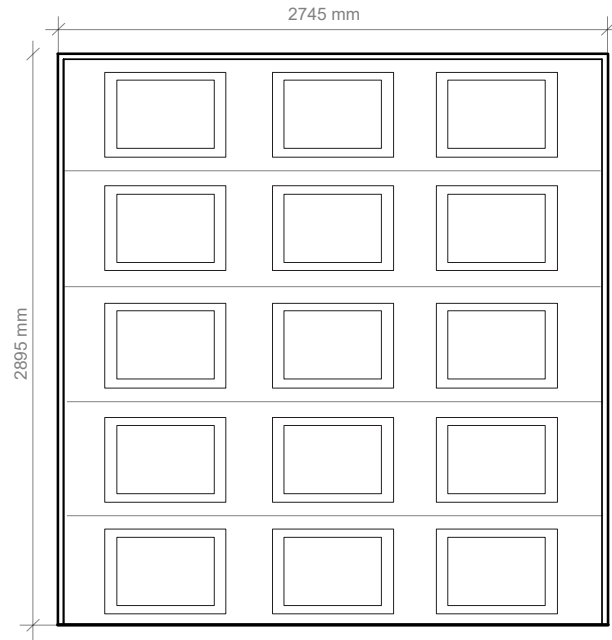
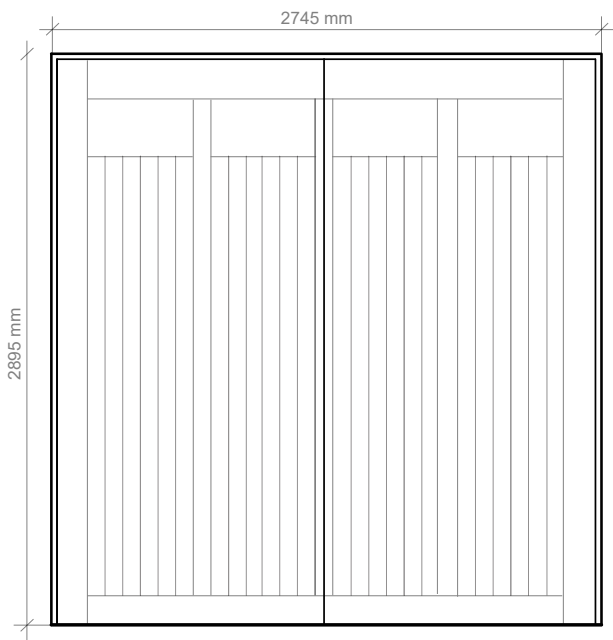

kale salad
[255,248,212]

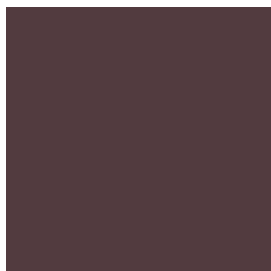

work the corner
[82,59,63]



chrome



shower shoes
[147,183,179]

rimessa

Doors



Doors



Windows, Shutters

Erin Doherty, Giovanna Veiga

Windows

Circles

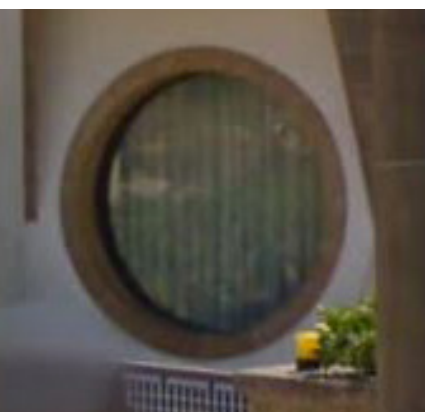
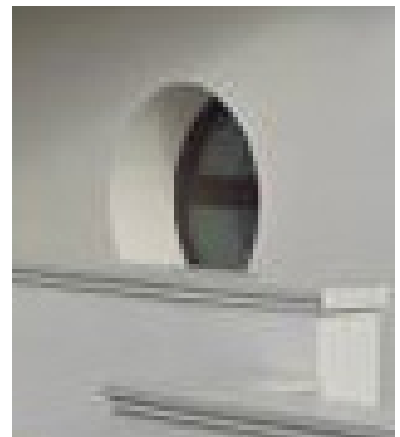
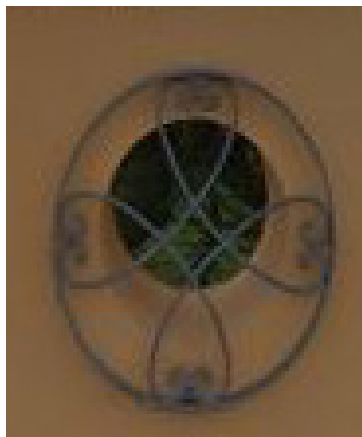
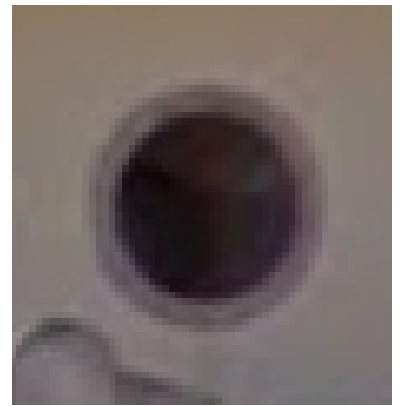
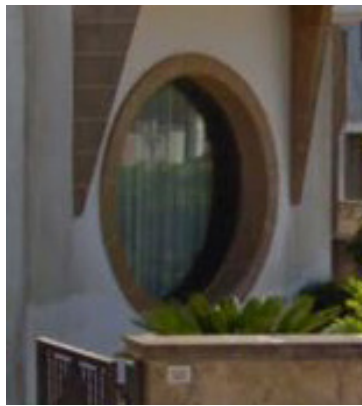

Windows

Irregular

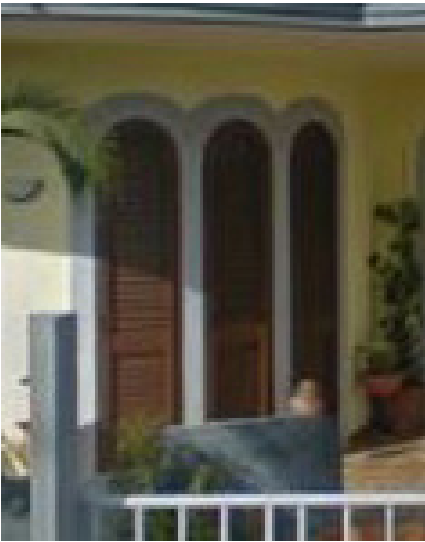
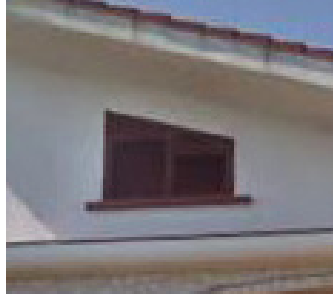

Windows

Squares

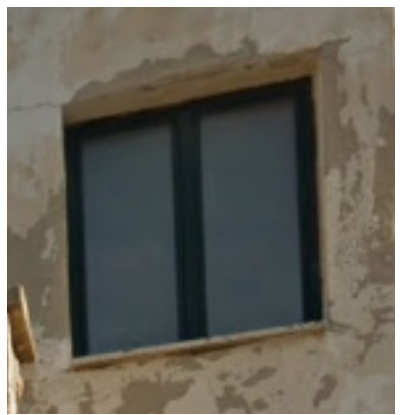
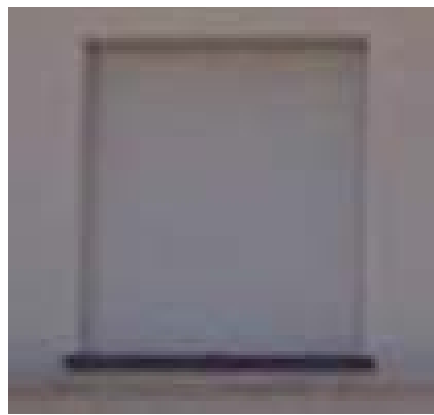
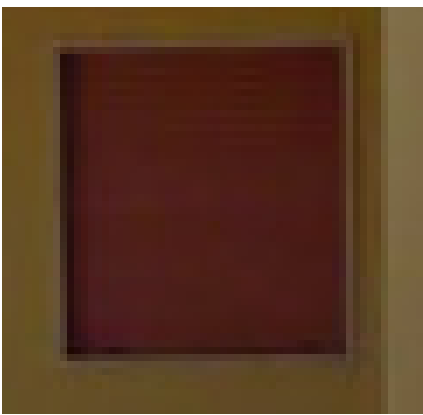
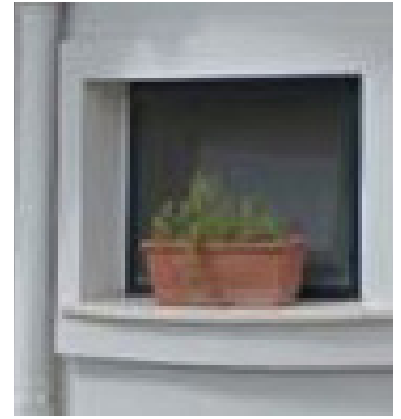
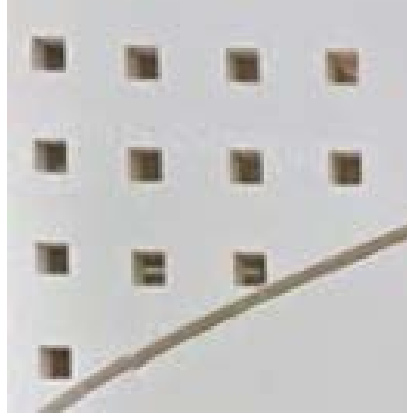

Windows

Rectangles

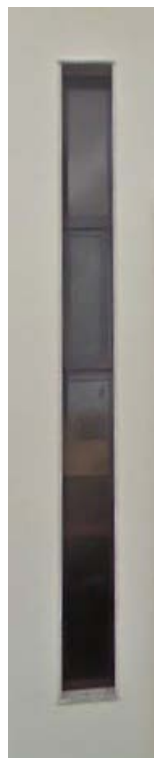
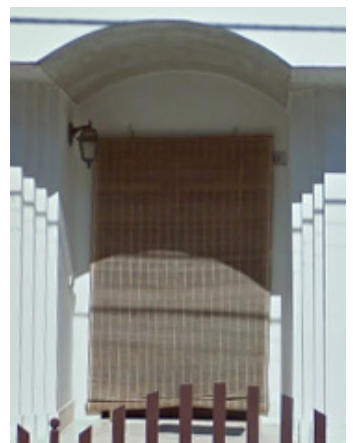
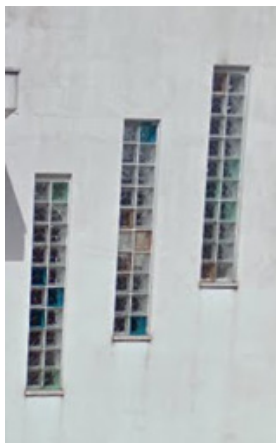
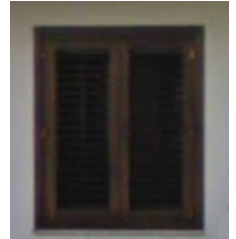
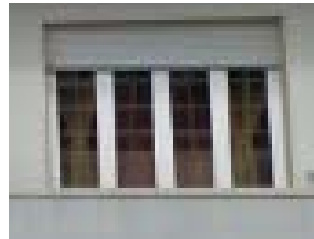
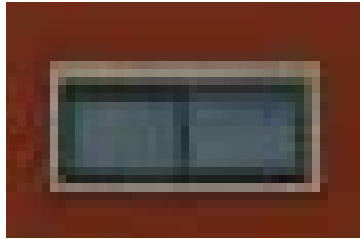
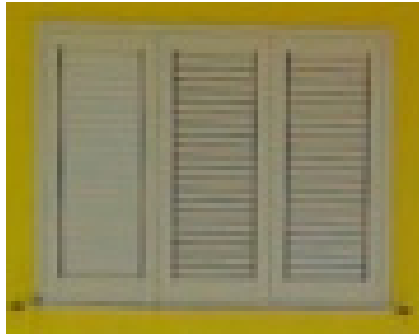

Windows

Facades

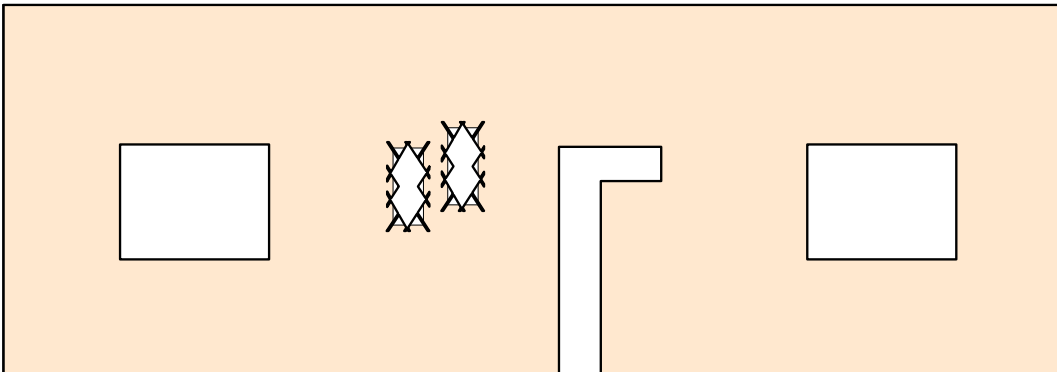
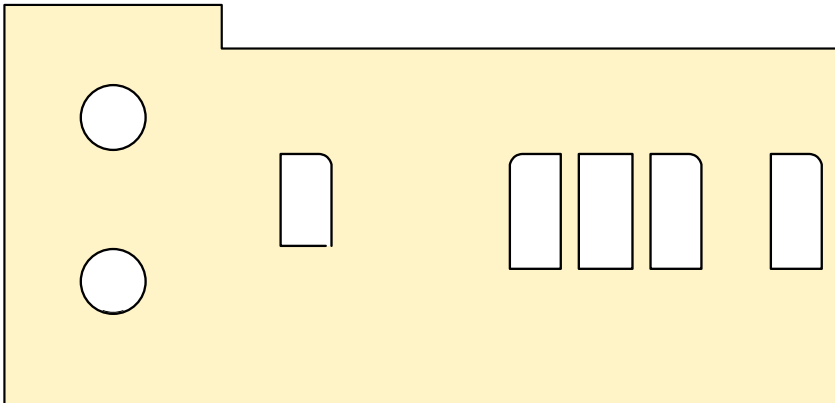
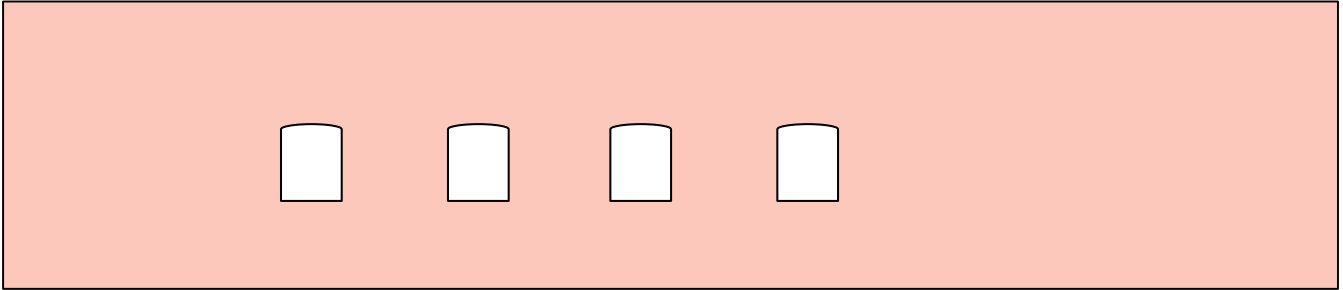

Windows

Windows

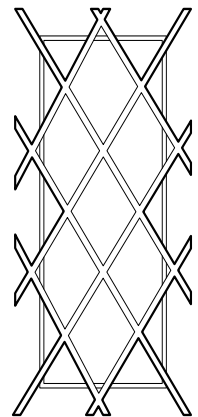
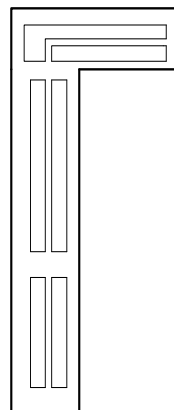
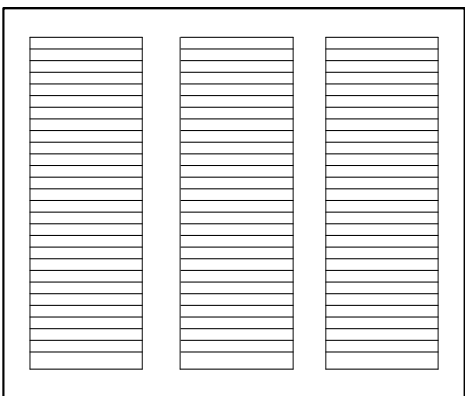
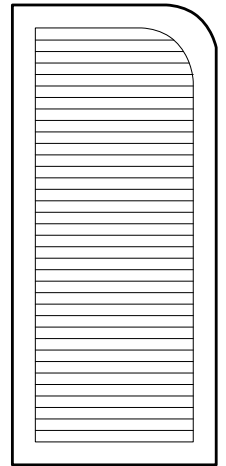
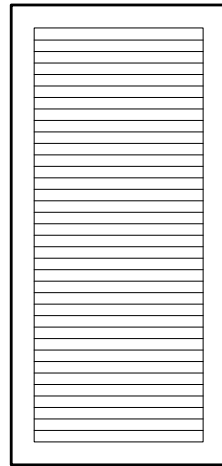
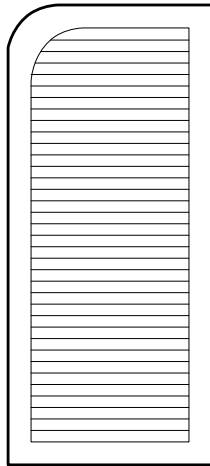
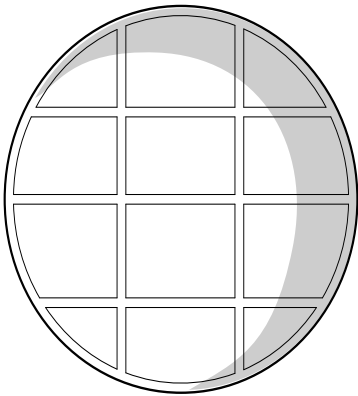
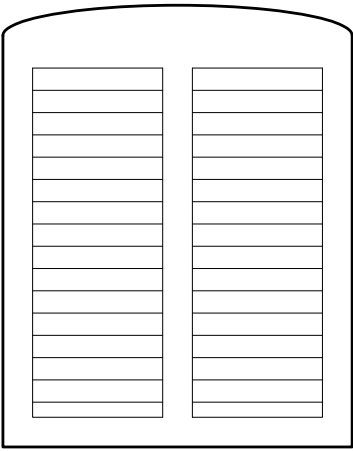

Windows

Facades

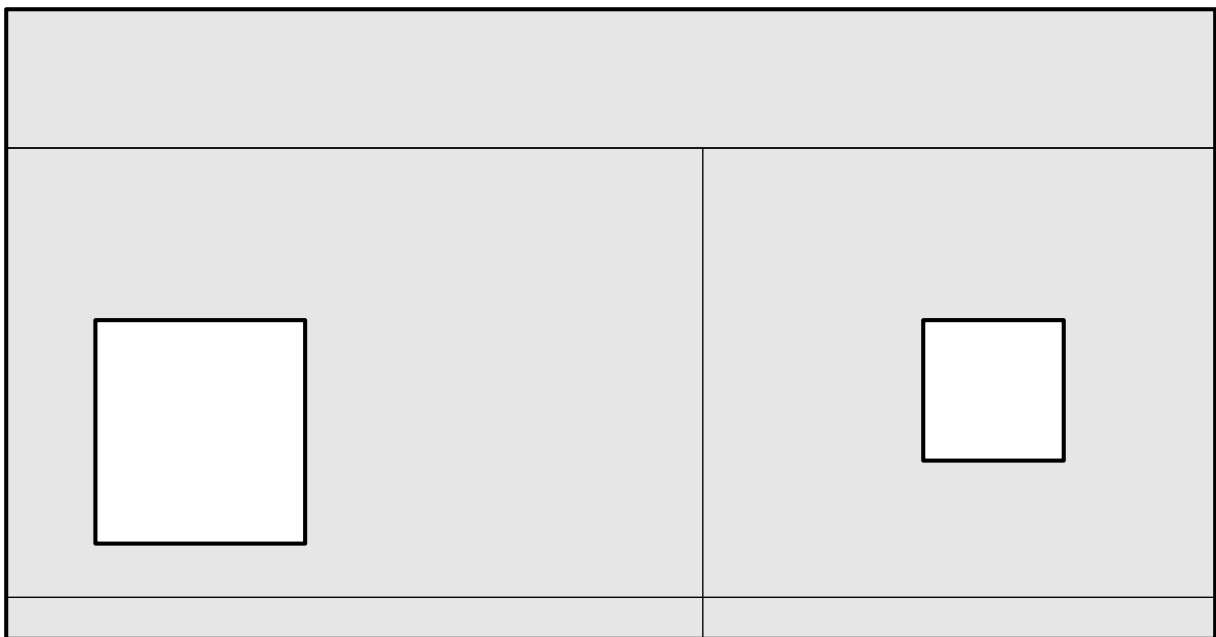
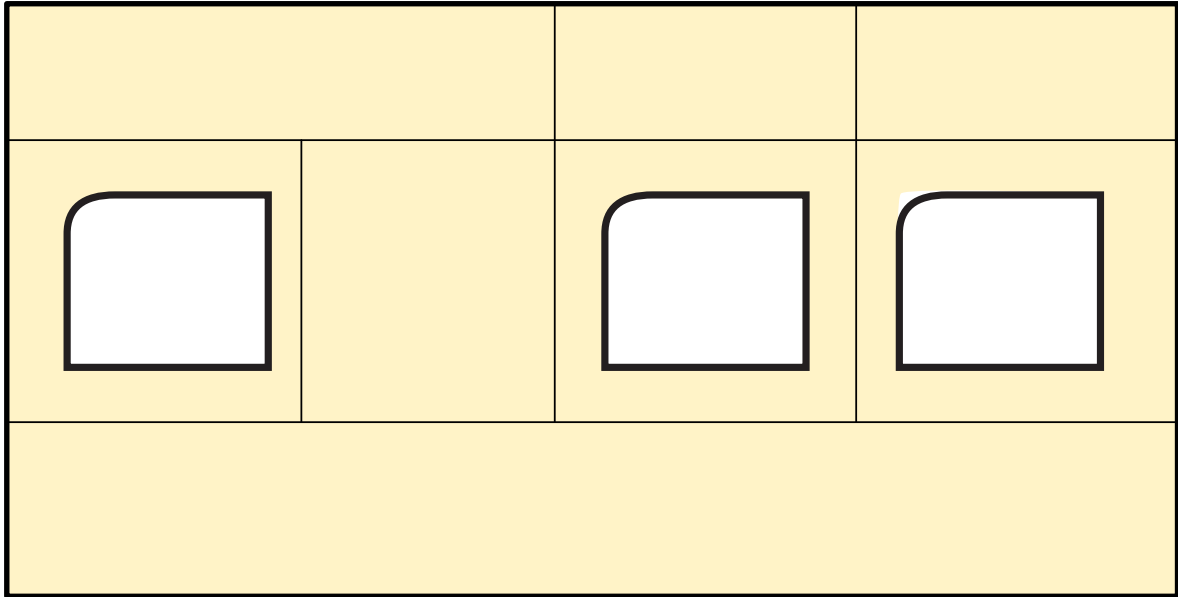

Windows

Windows

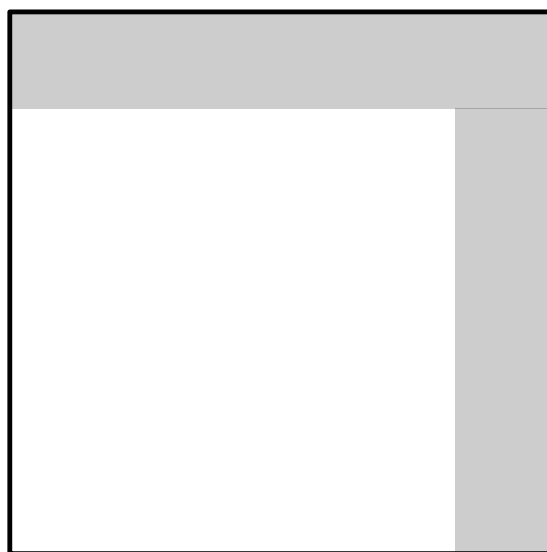
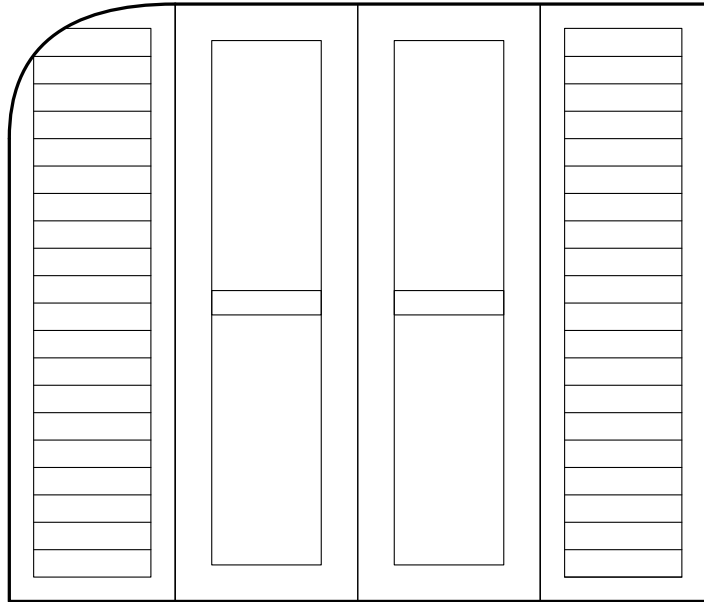

Windows

Facades

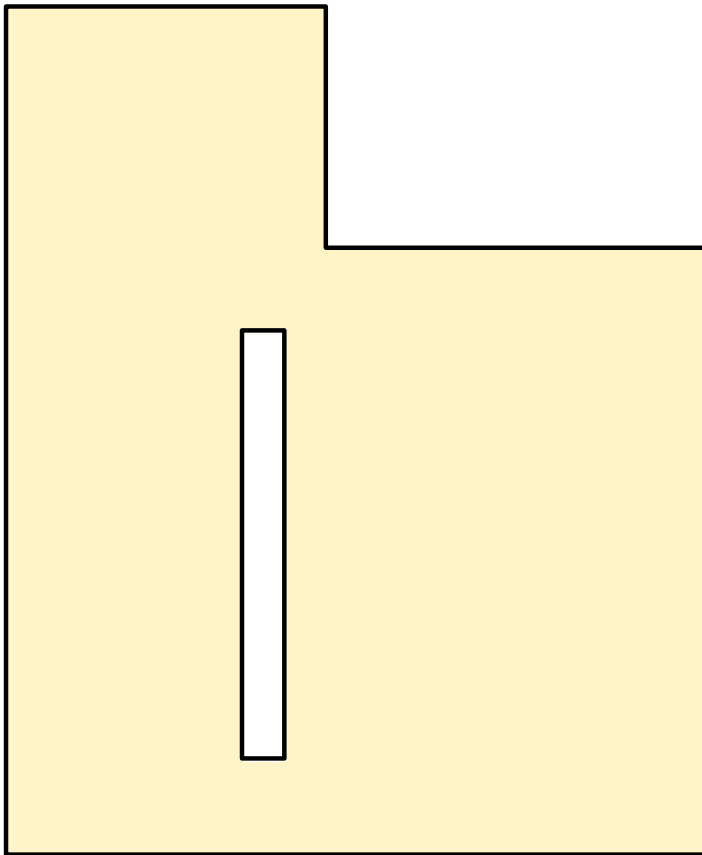
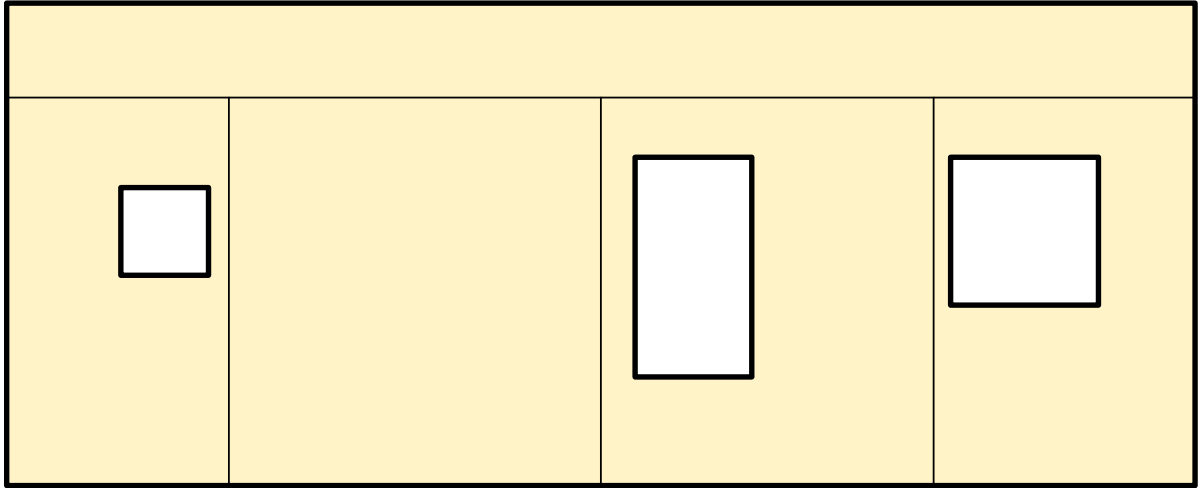

Windows

Windows

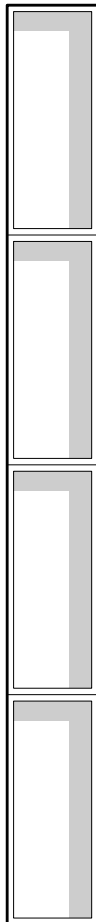
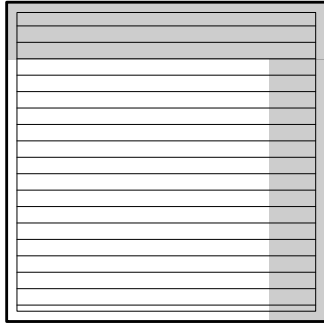

Windows

Facades

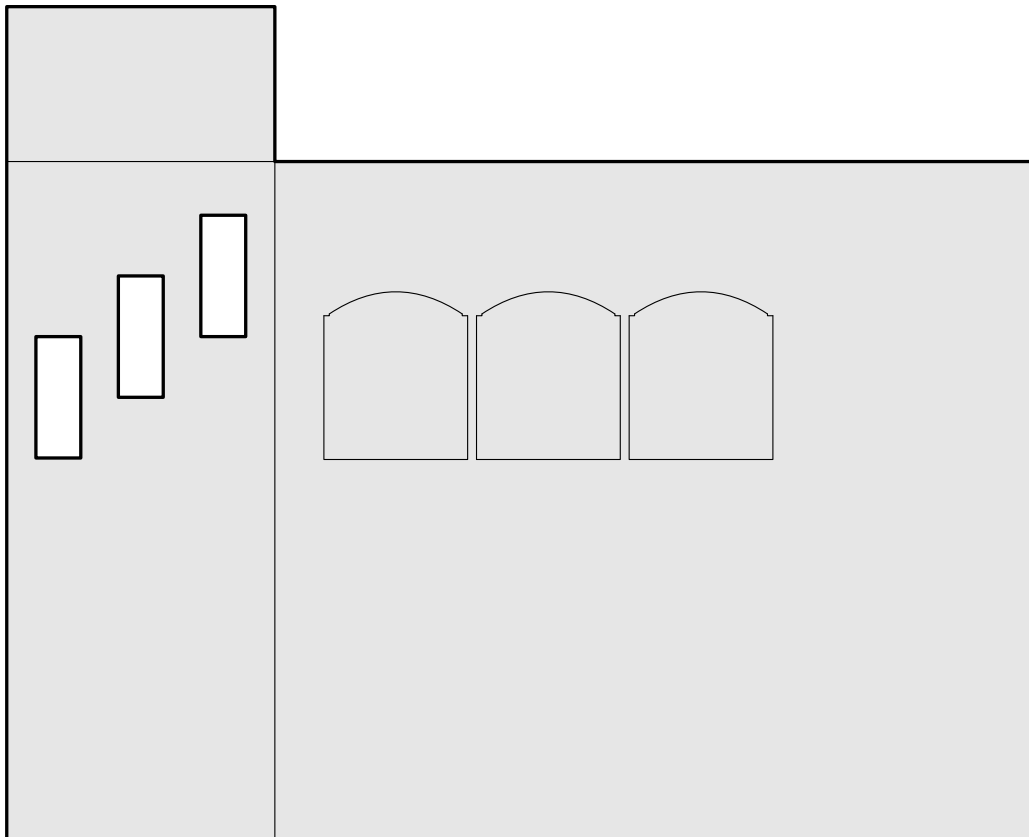
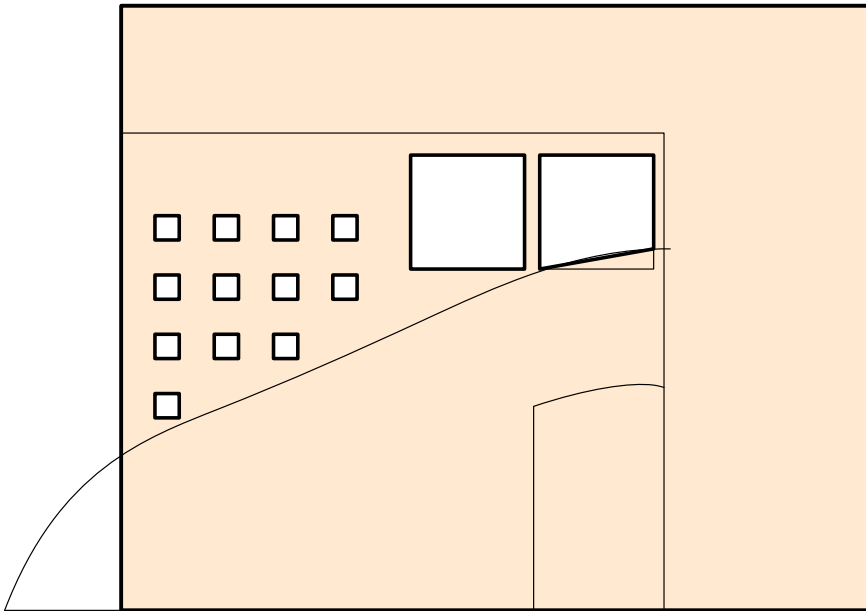

Windows

Windows

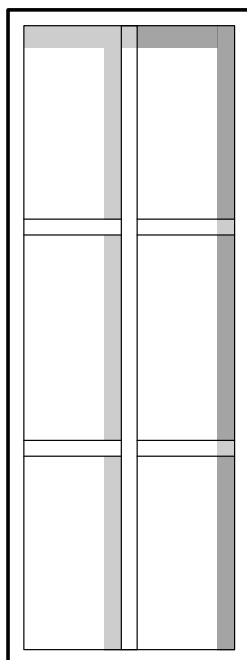
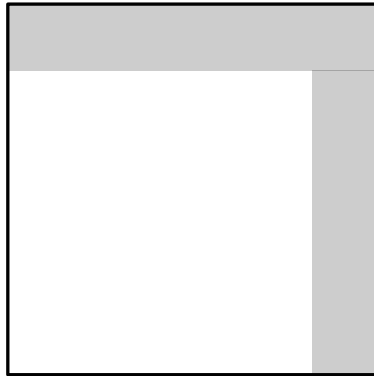
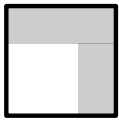

Windows

Facades

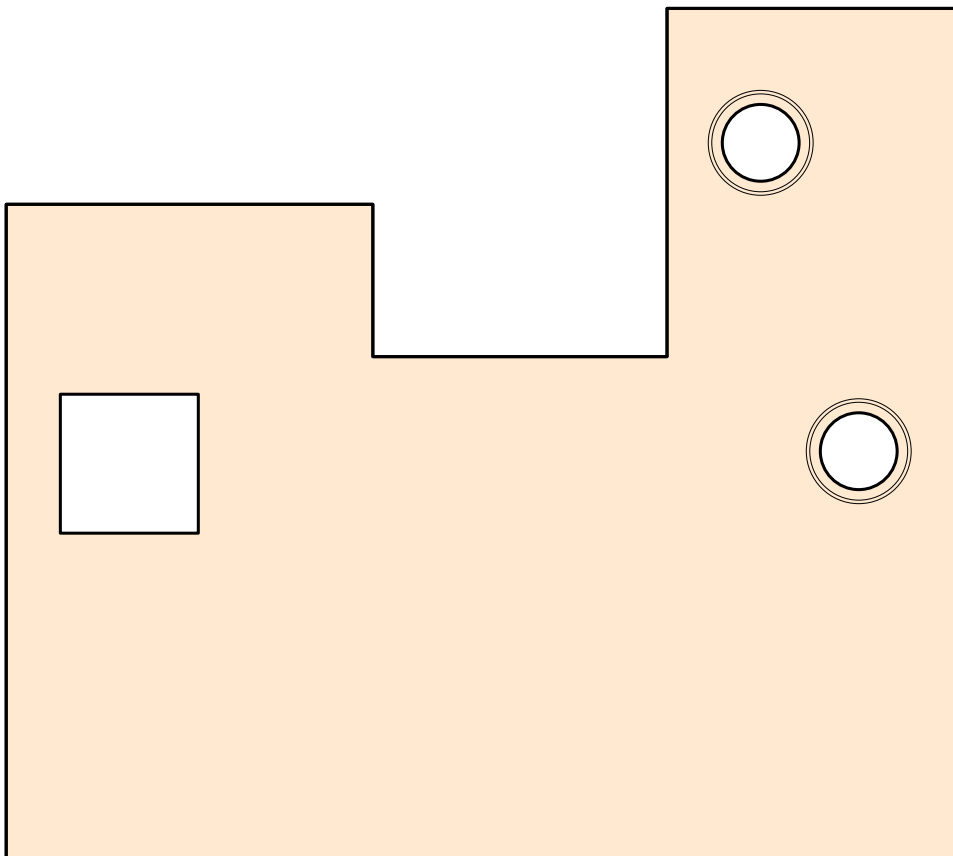
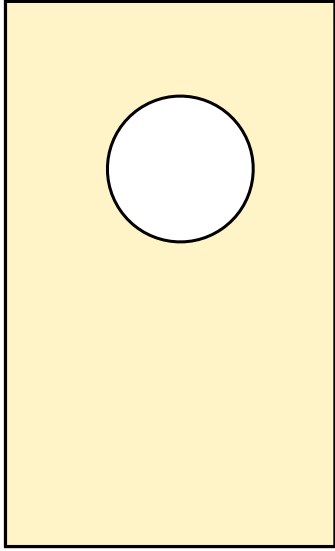

Windows

Windows

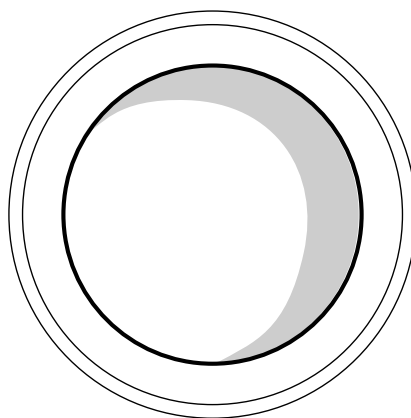
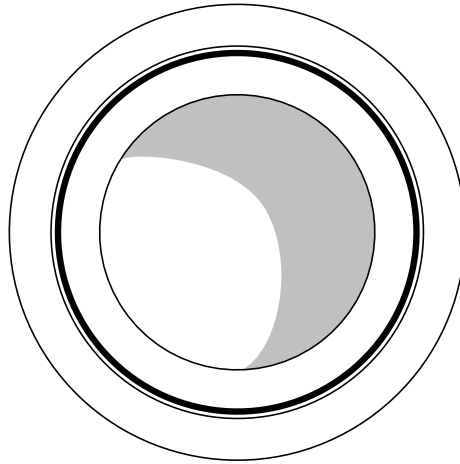

Windows

Coverings (Nothing)

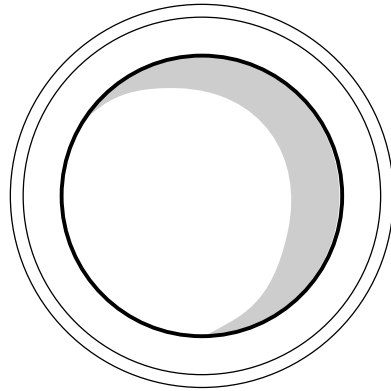
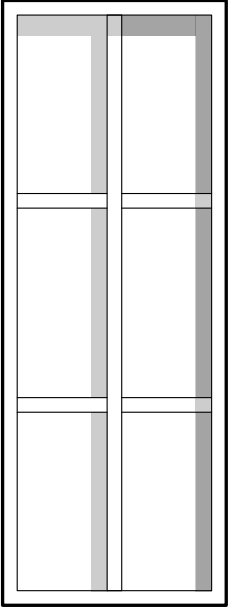
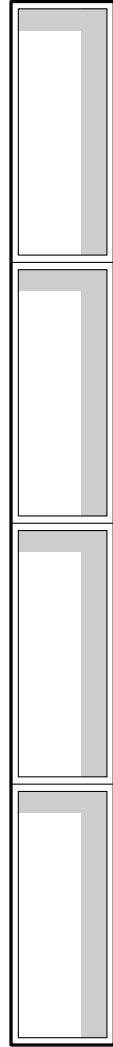
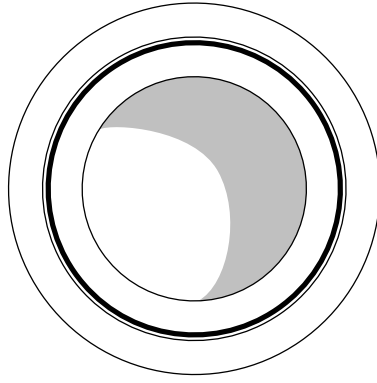
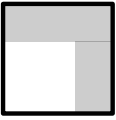

Coverings (Shutters)

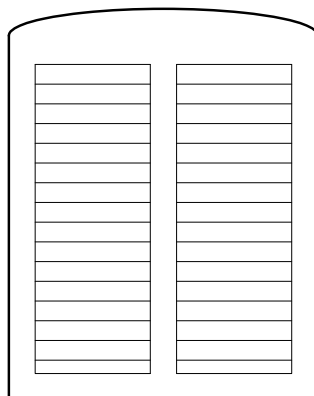
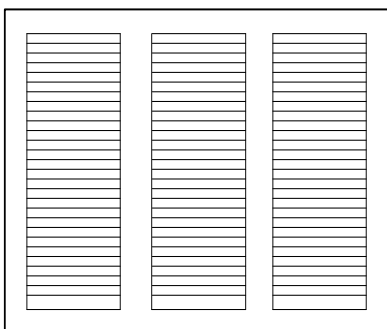
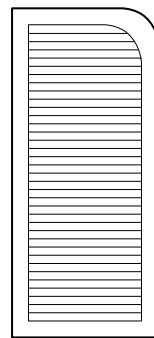
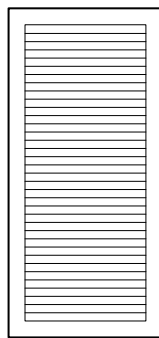
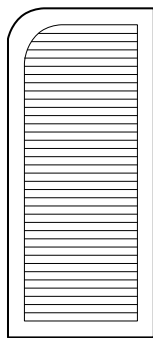
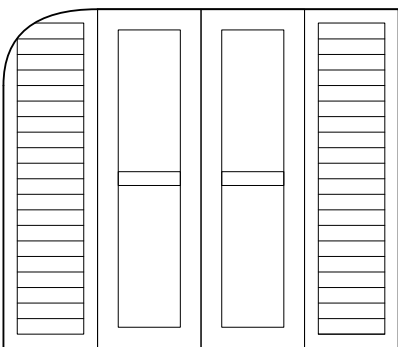

Windows

Coverings (Grate)

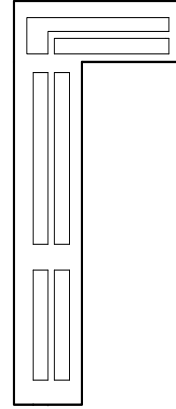
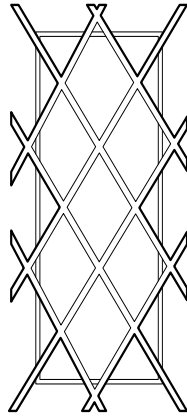
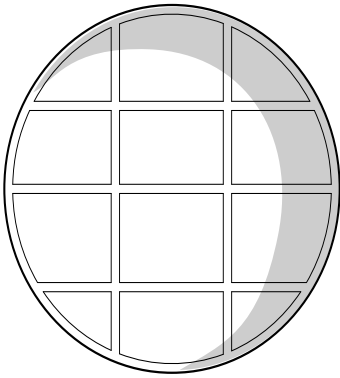

Coverings (Blinds)

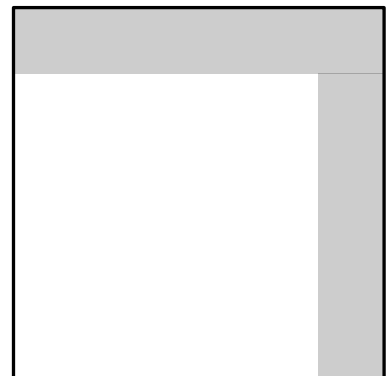
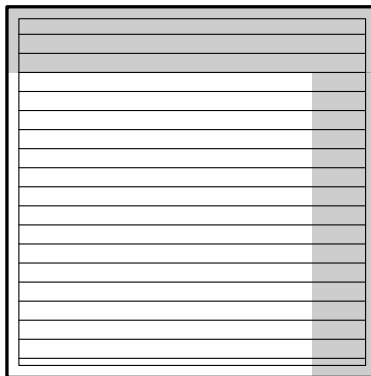

Windows

Elevation (Sunk-in)

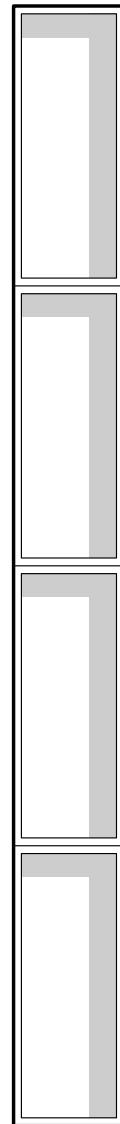
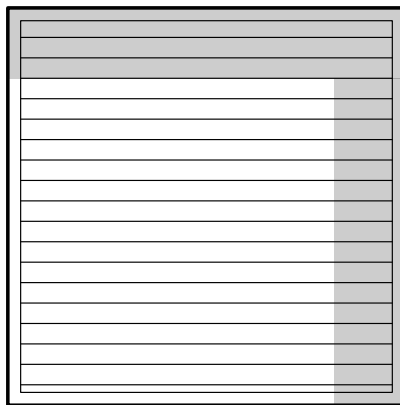
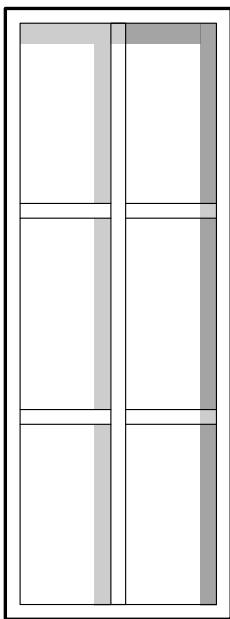
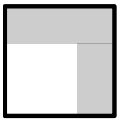
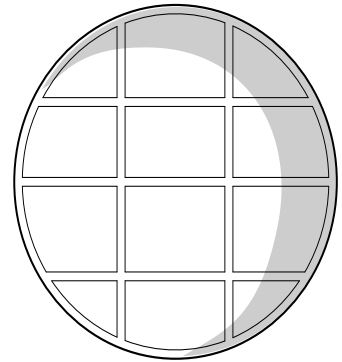
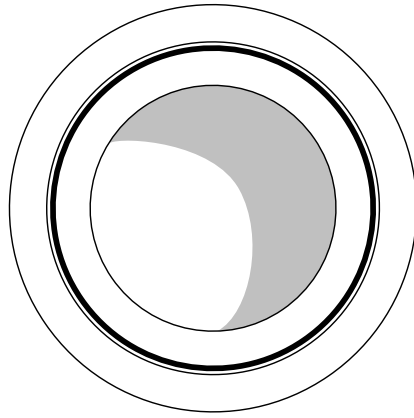
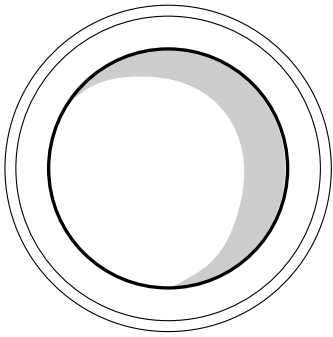

Windows

Elevation (Flush)

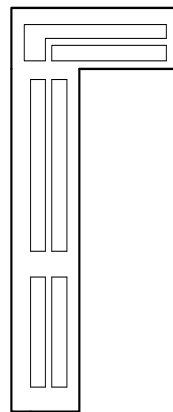
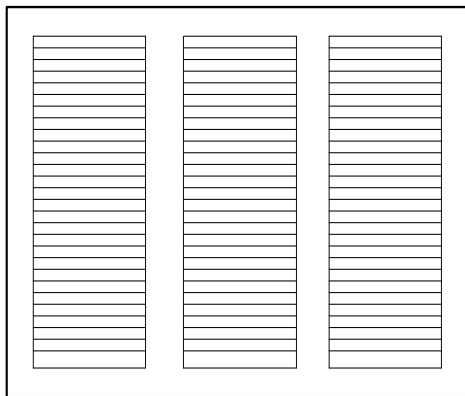
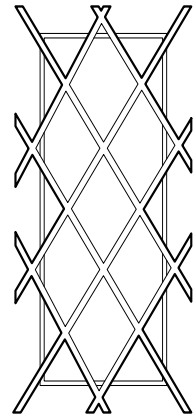
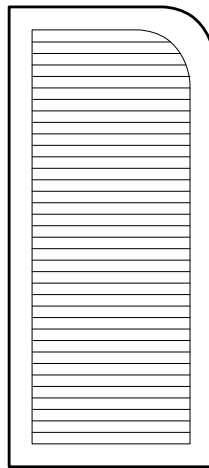
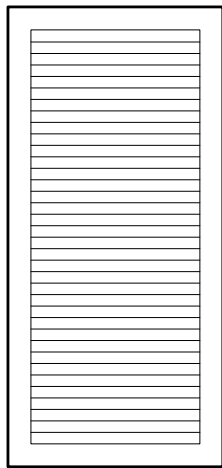
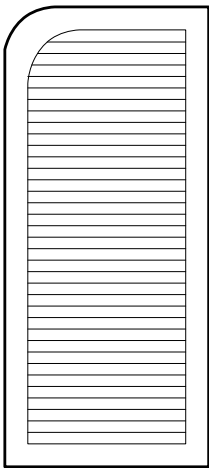
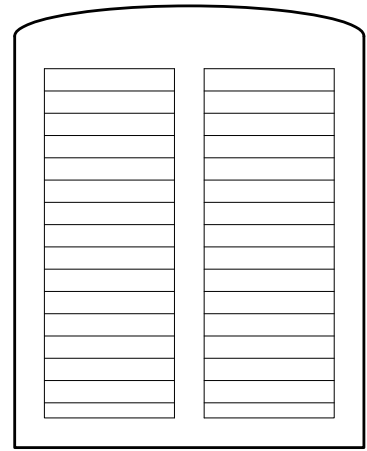
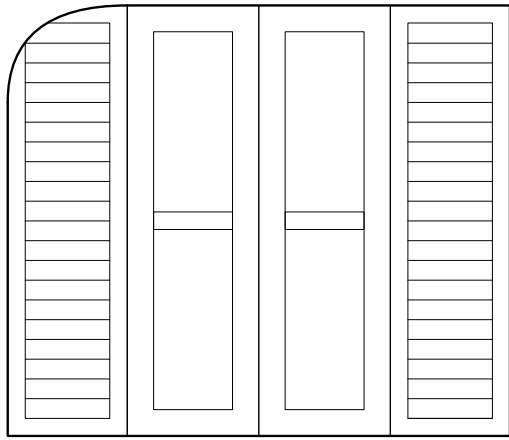

Windows

Shapes (Squares)

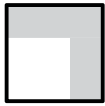
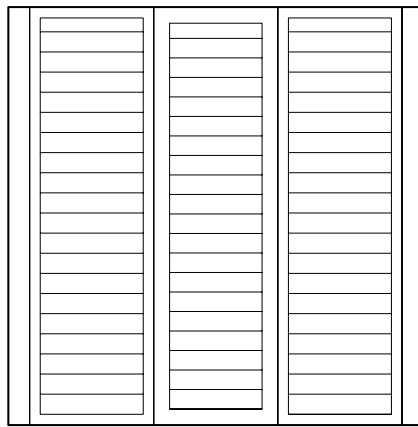
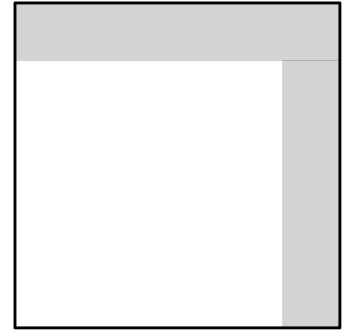
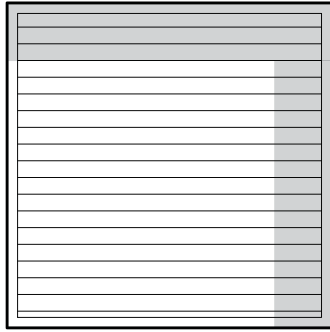

Shapes (Circles)

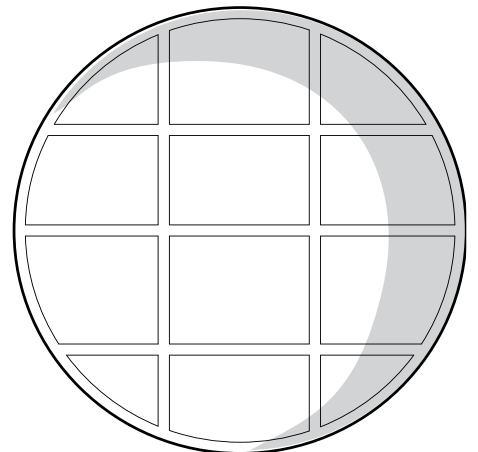
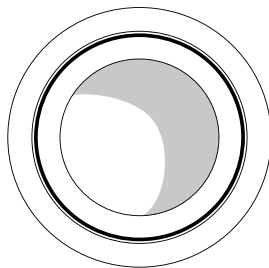
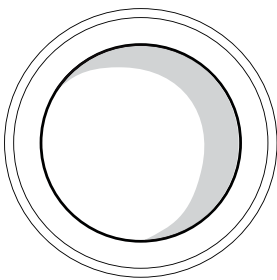

Windows

Shapes (Rectangle)

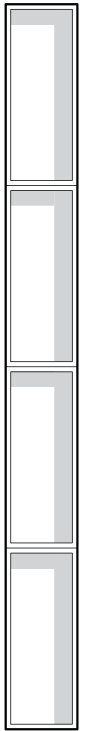
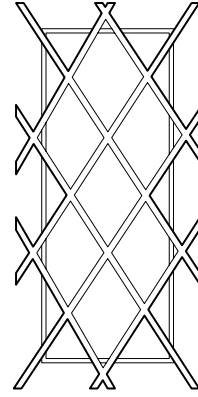
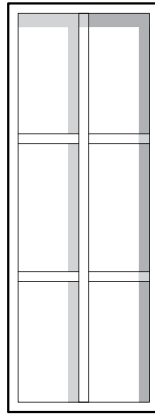
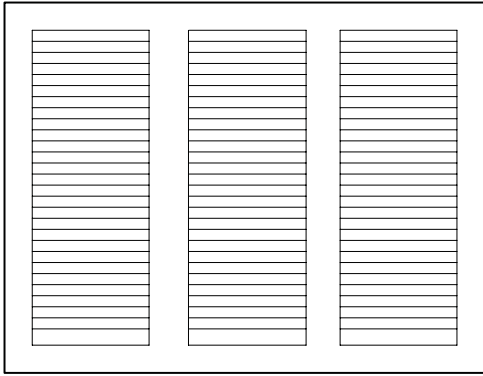

Shapes (Irregular)

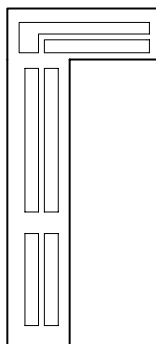
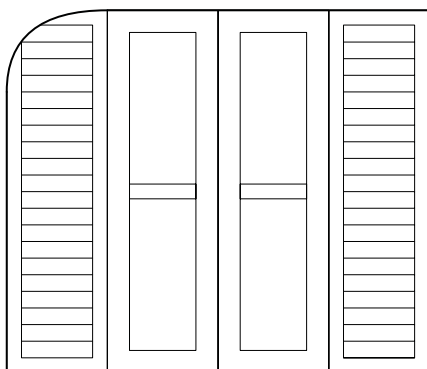
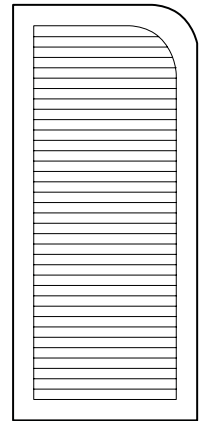
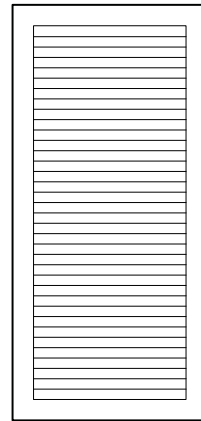
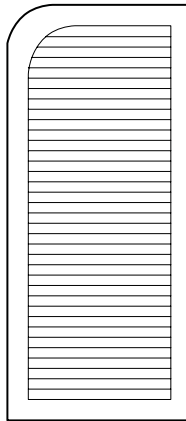
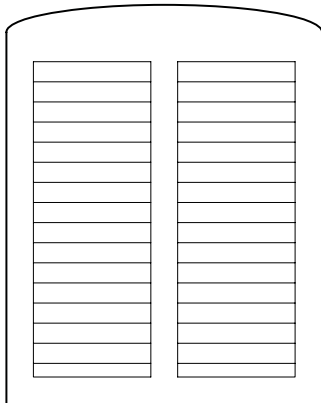

Stairs

Timothy Mulhall, Stella Dai

Stairs

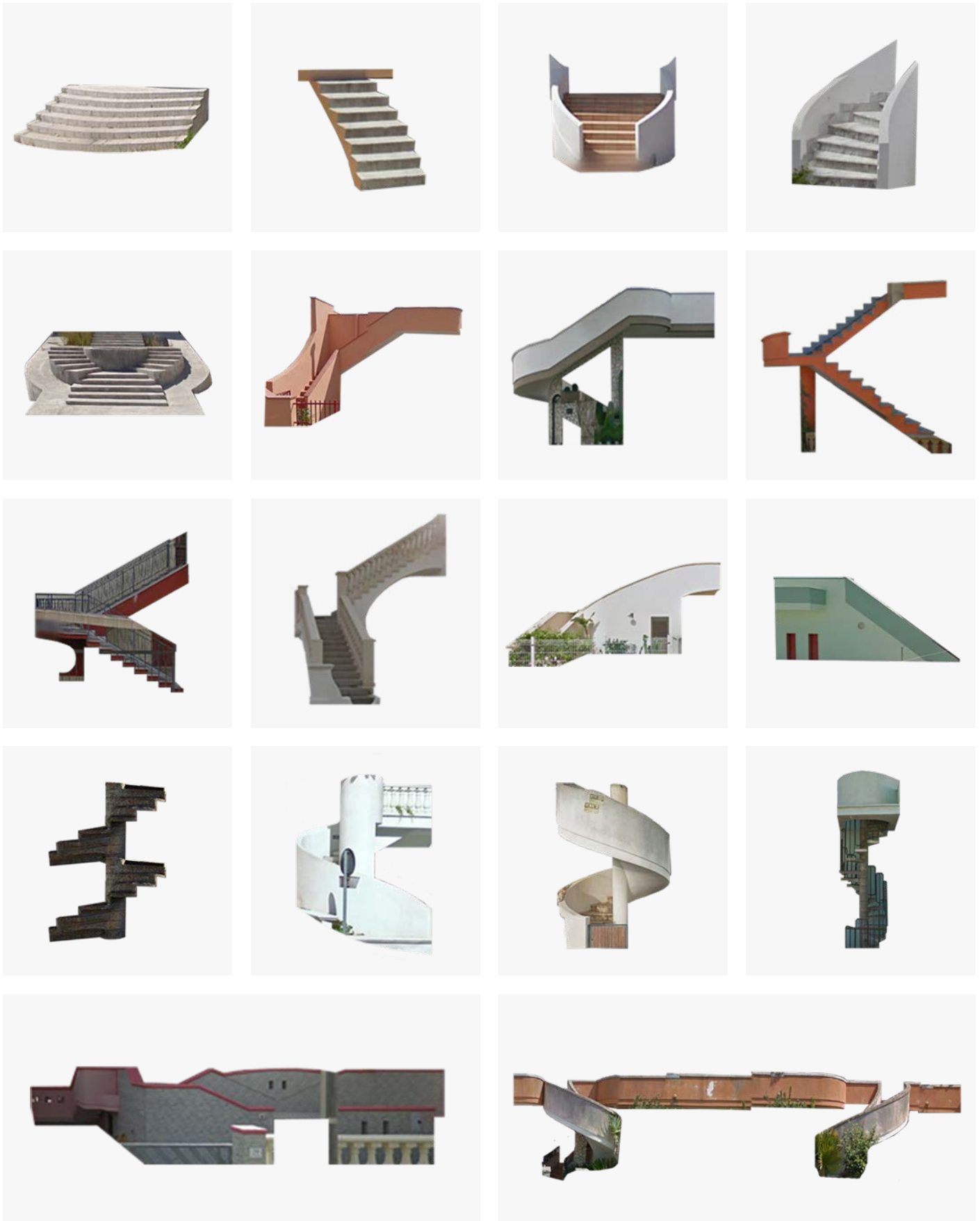

Stairs

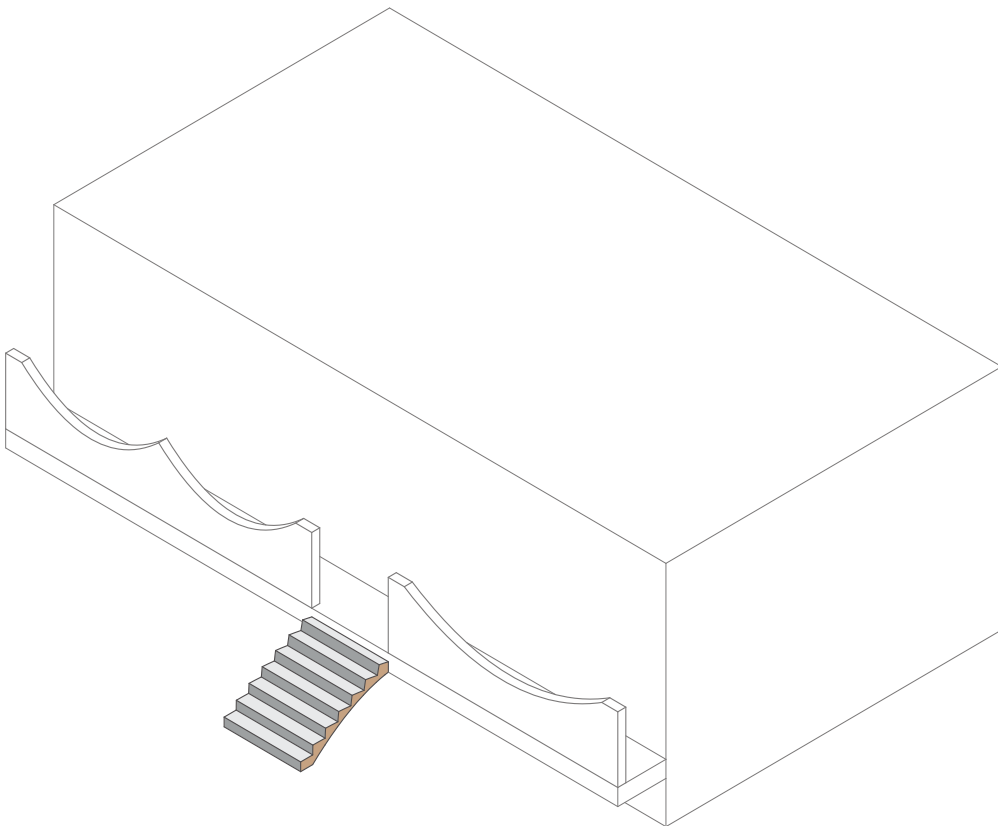
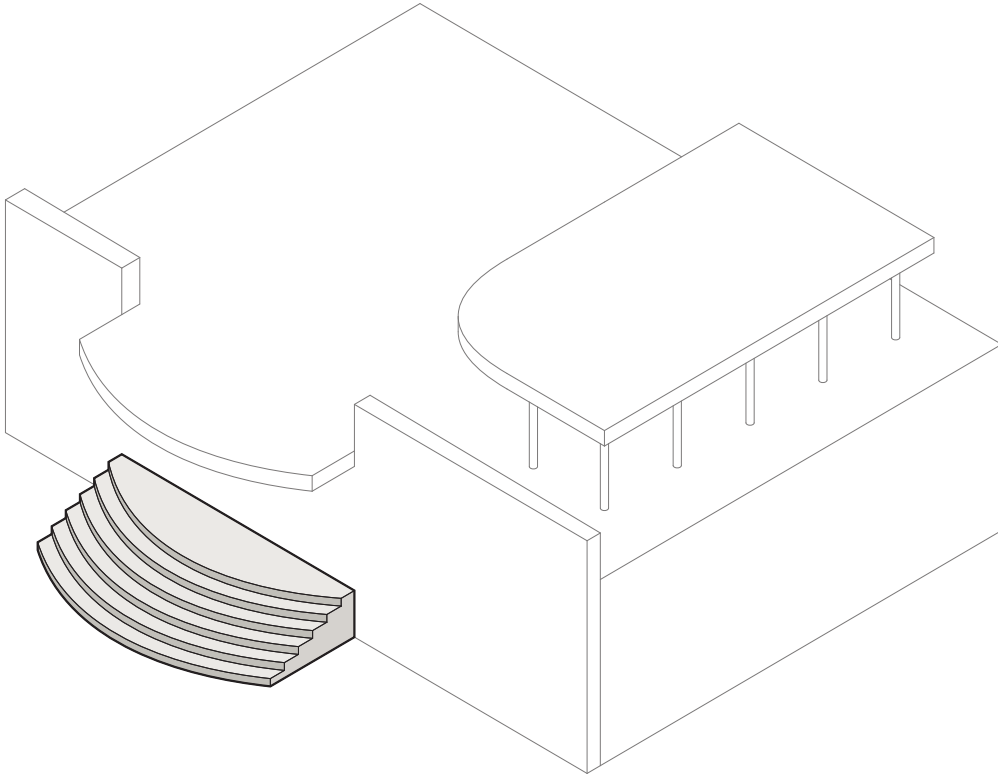

The Half Storey Step

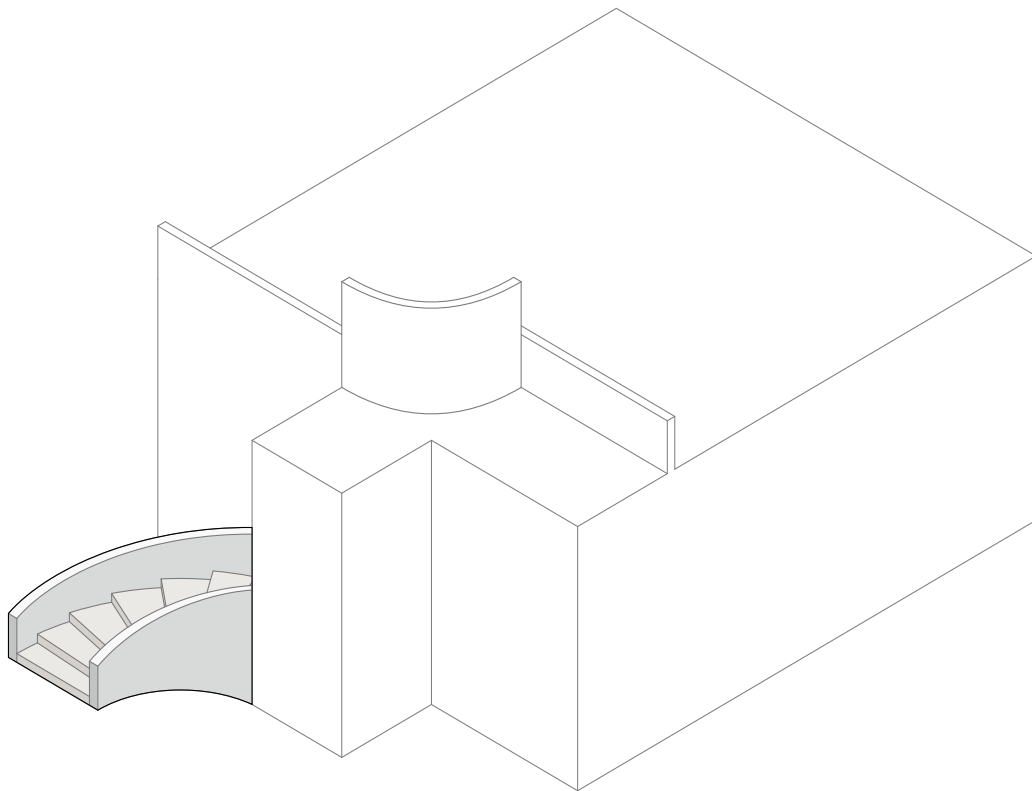
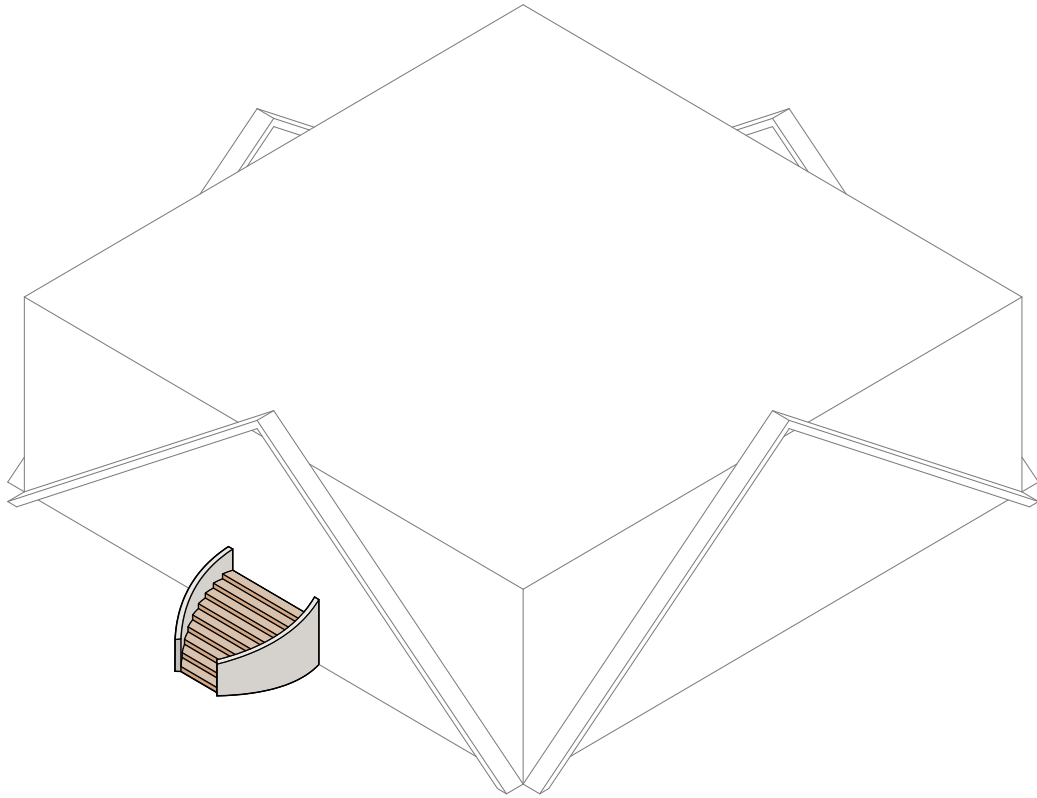

The Half Storey Step

Stairs

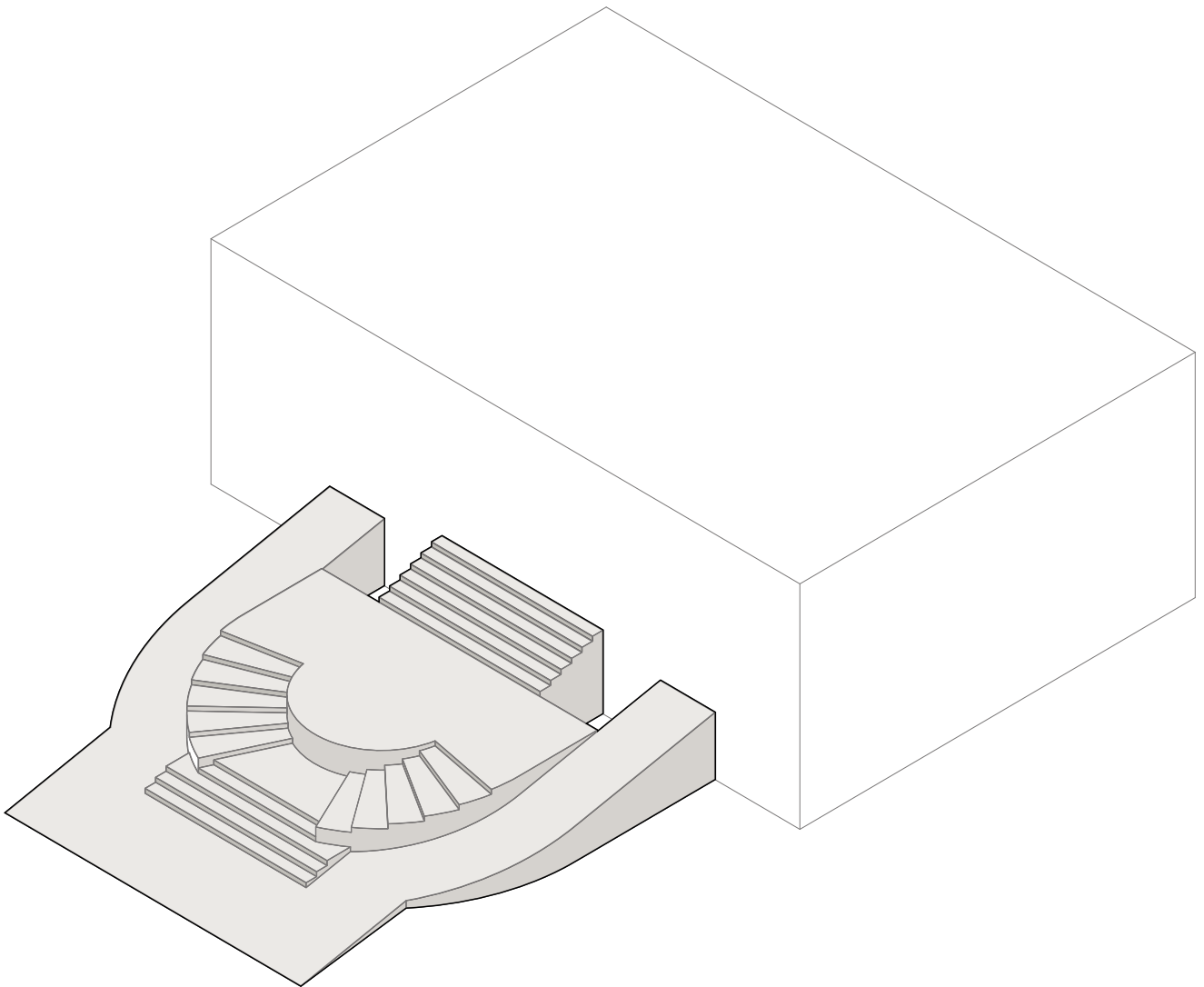

The Half Storey Step

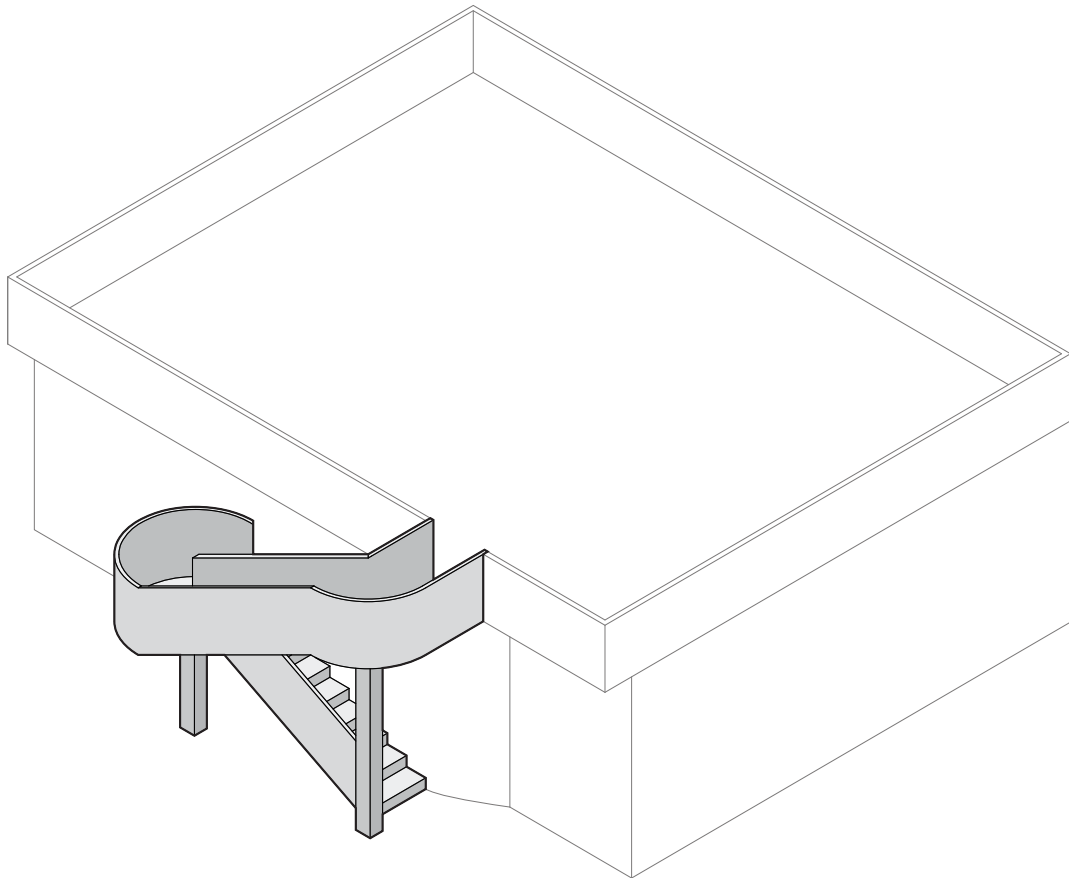
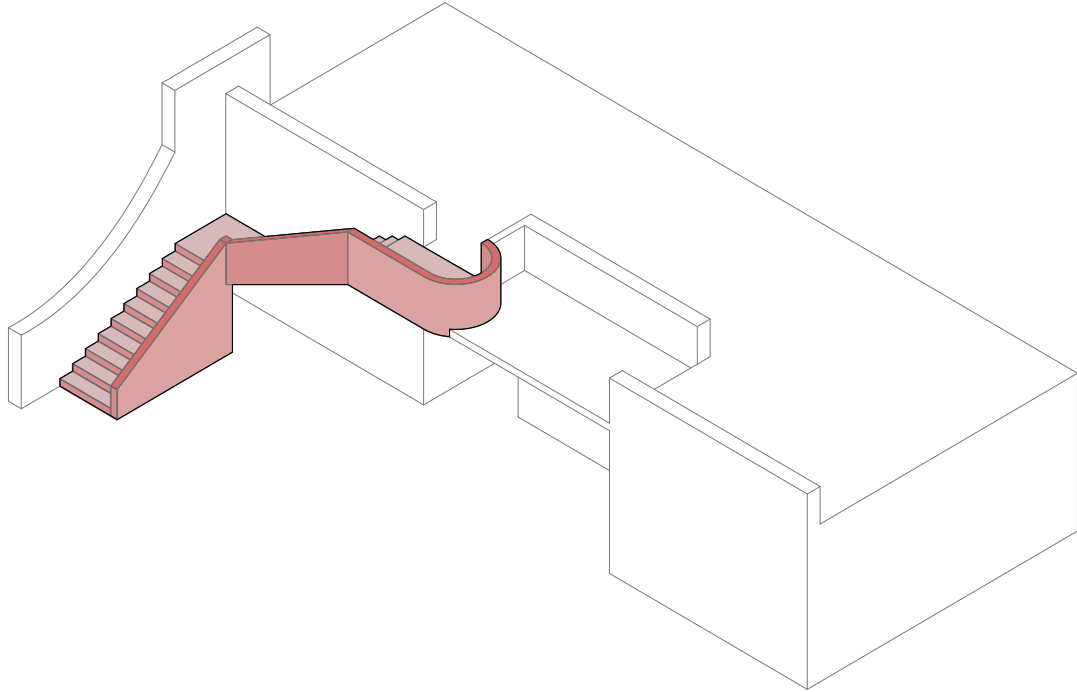

The Two Storey Stretch

Stairs

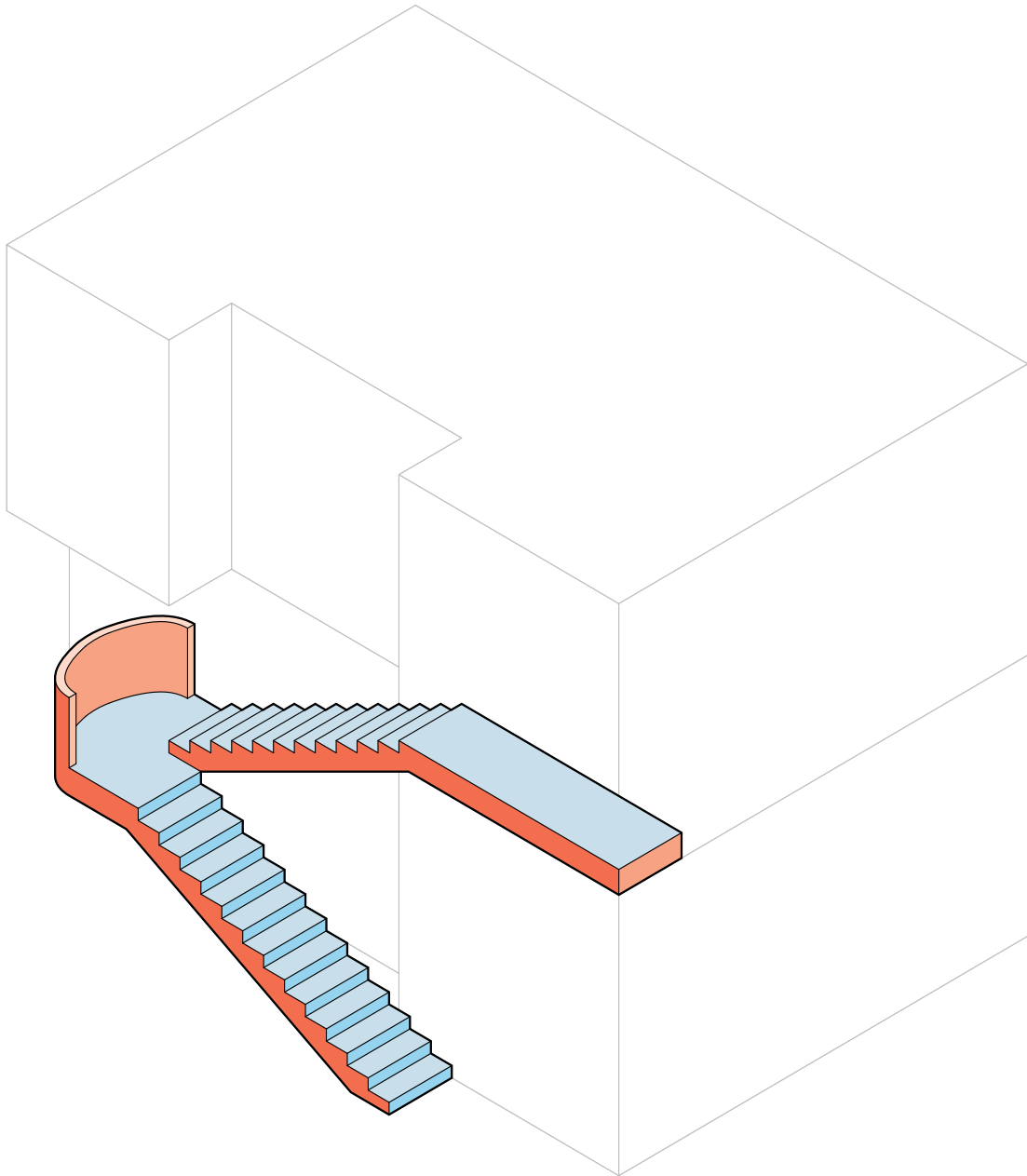

The Two Storey Stretch

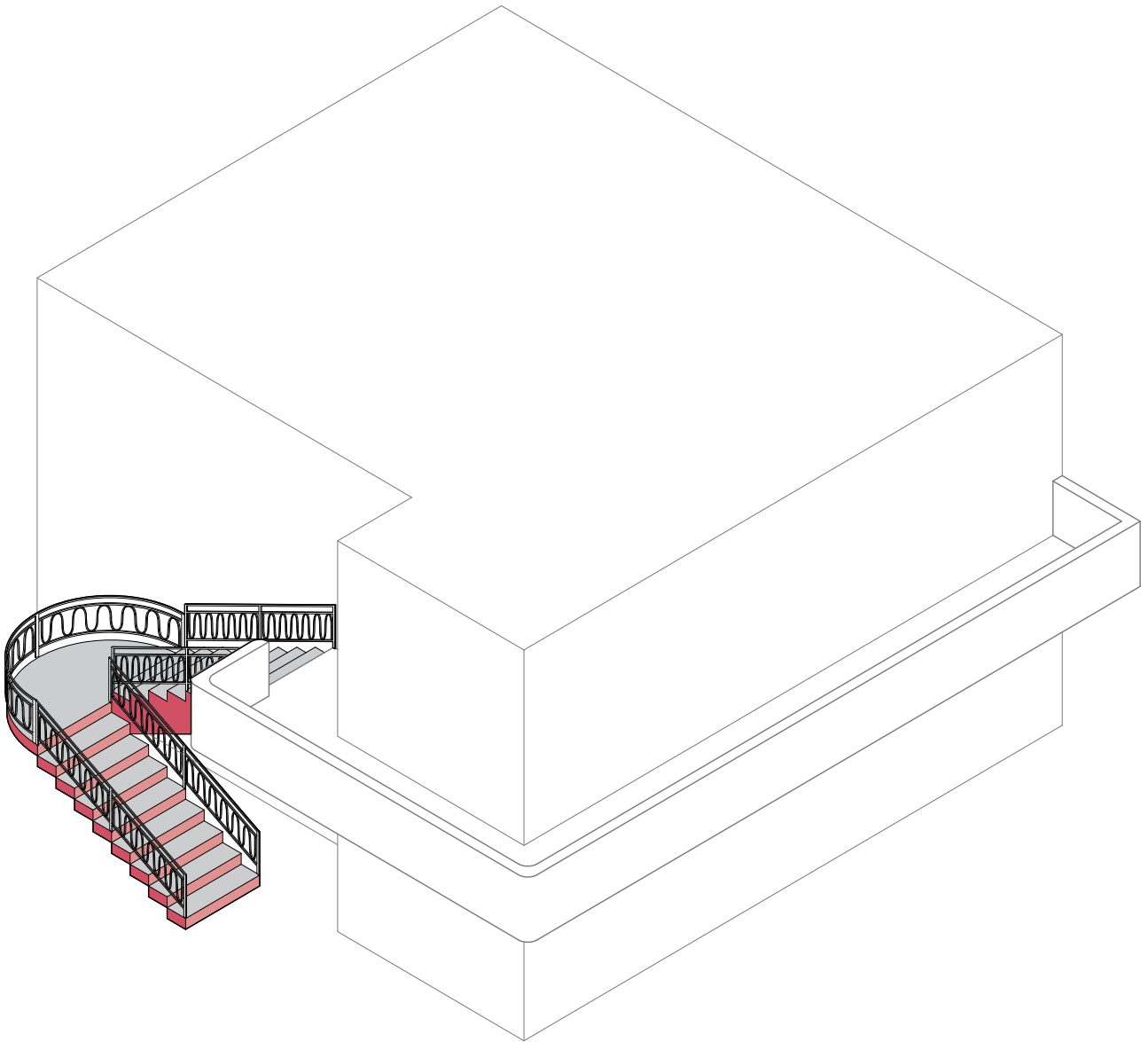

The Two Storey Stretch

Stairs

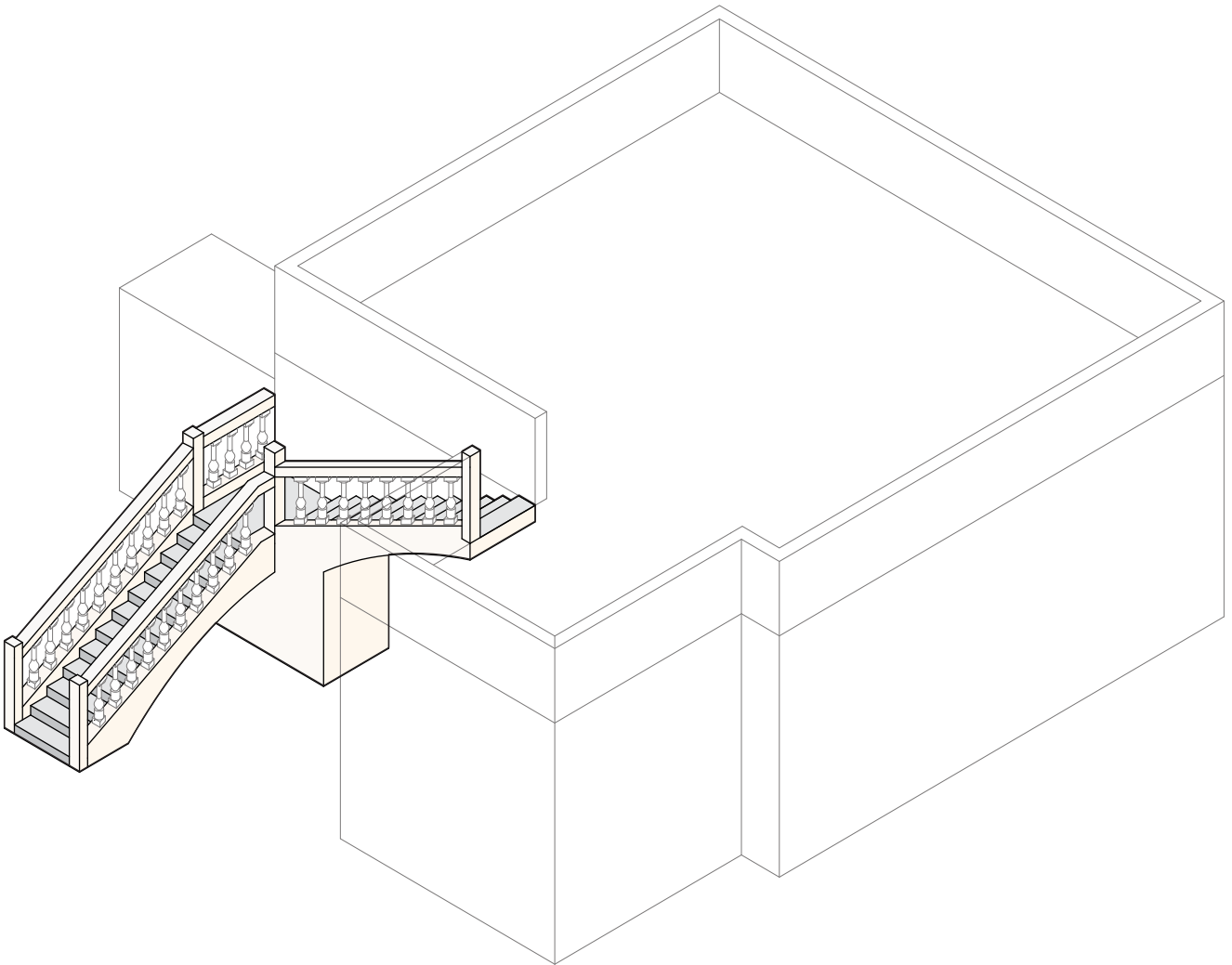

The Two Storey Stretch

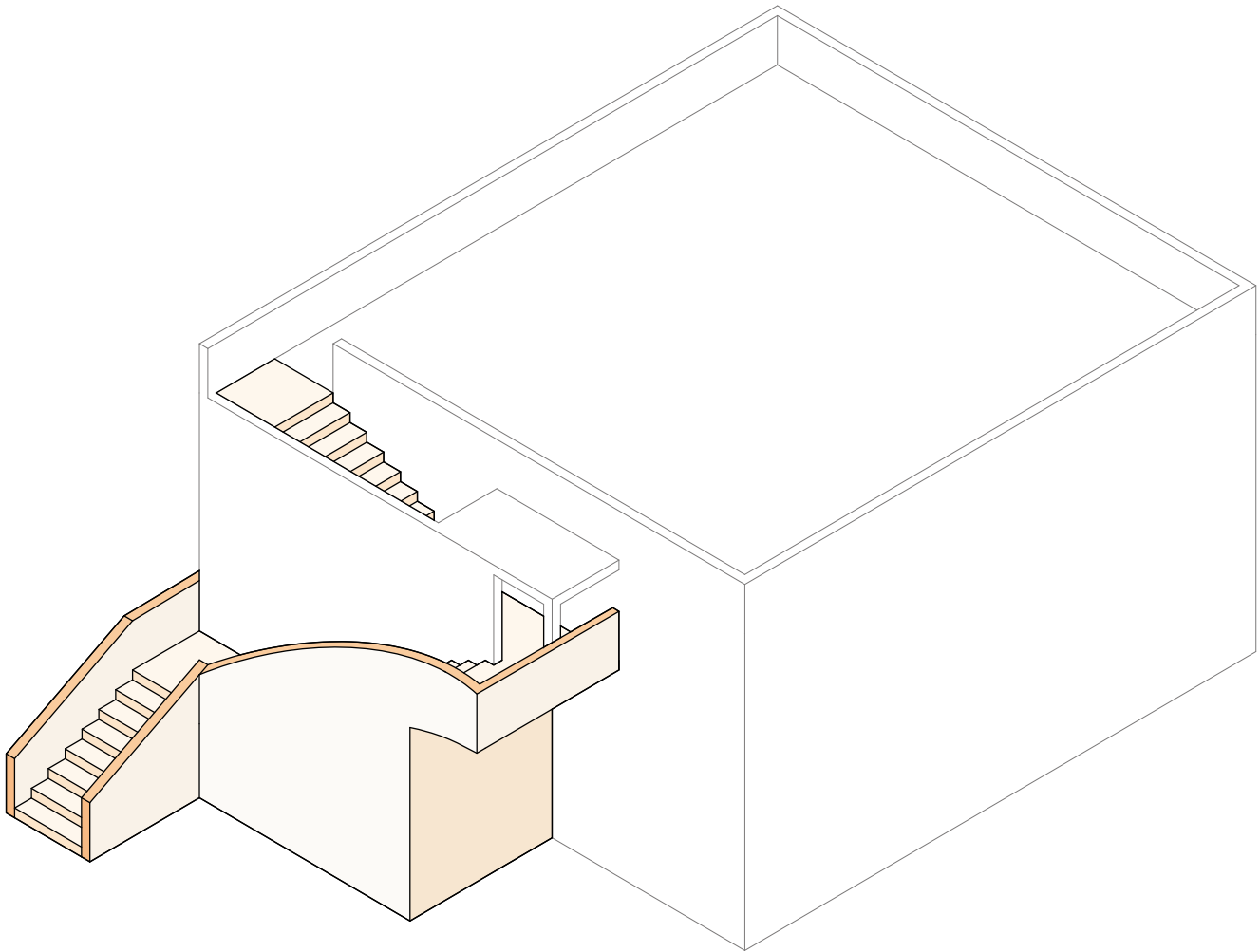

The Face Lift

Stairs

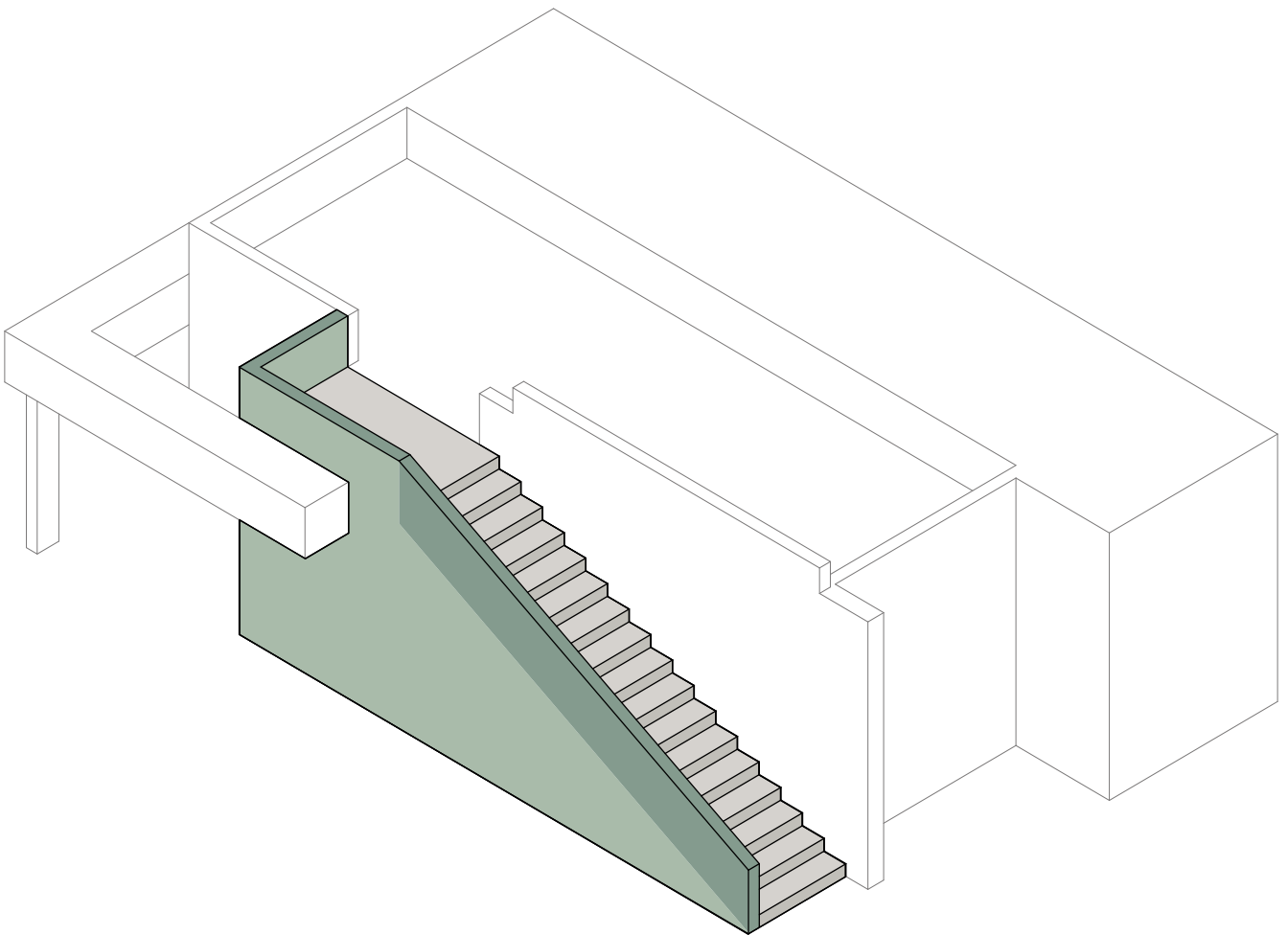

The Face Lift

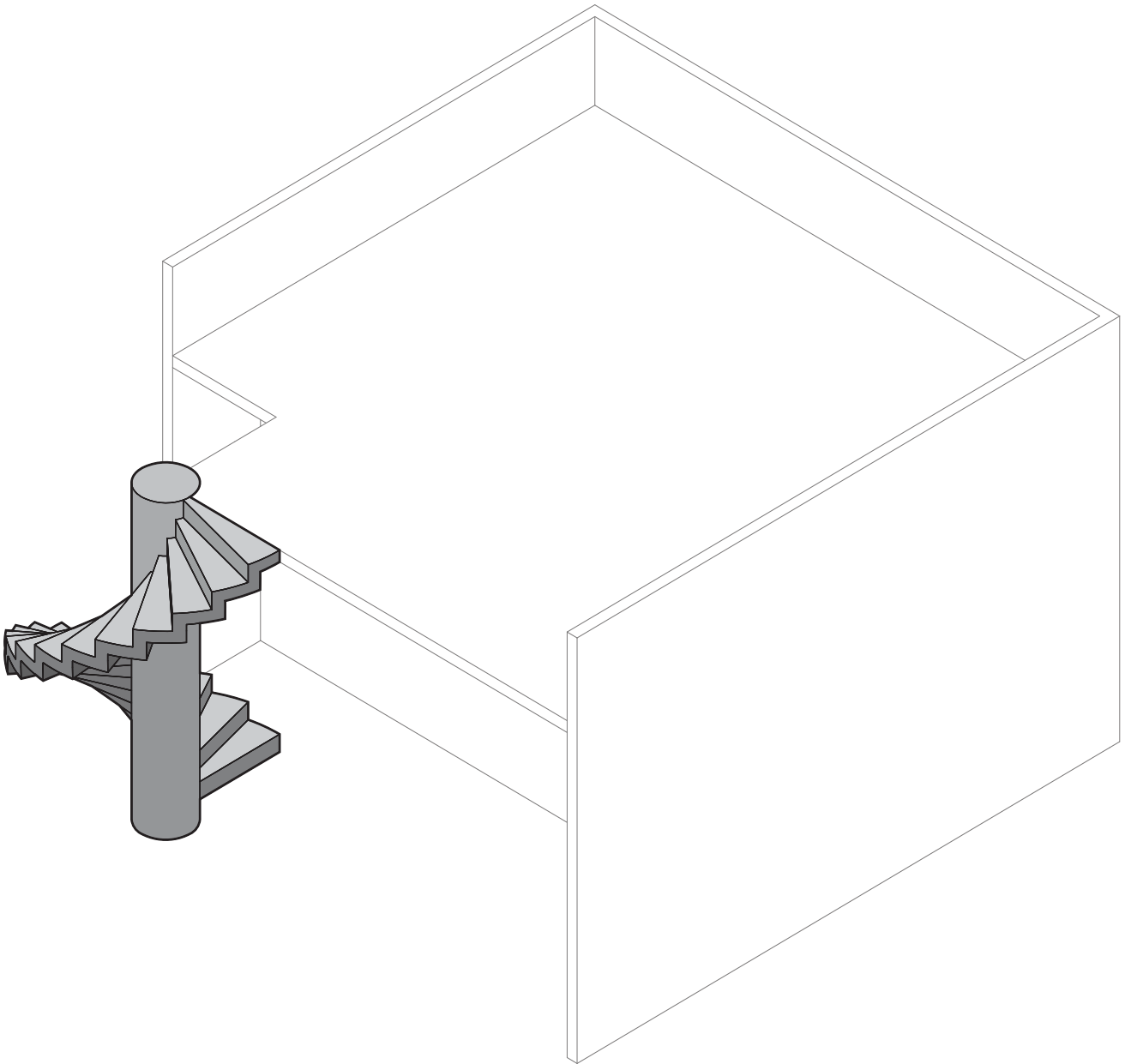

The Full Spiral

Stairs

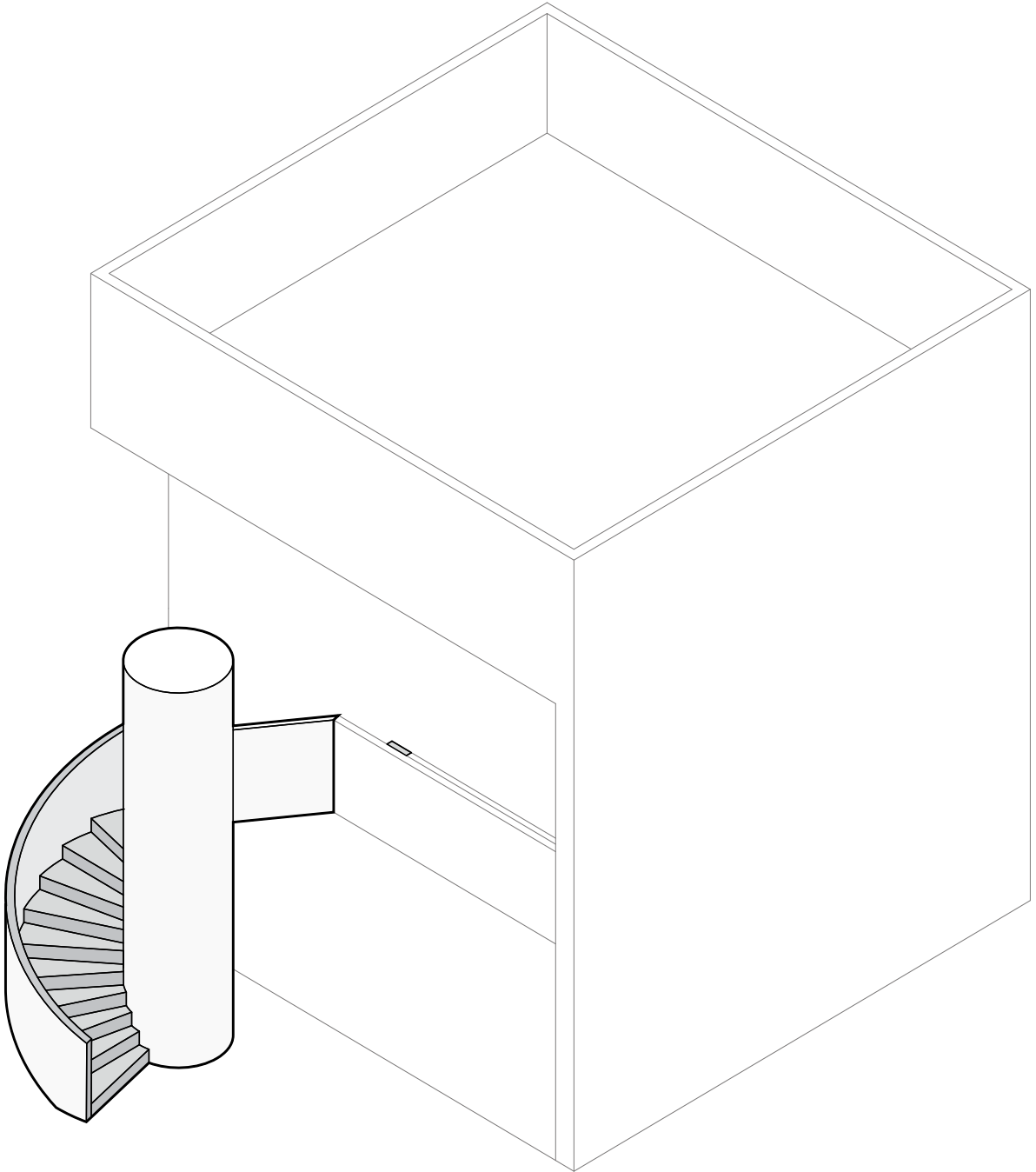

The Full Spiral

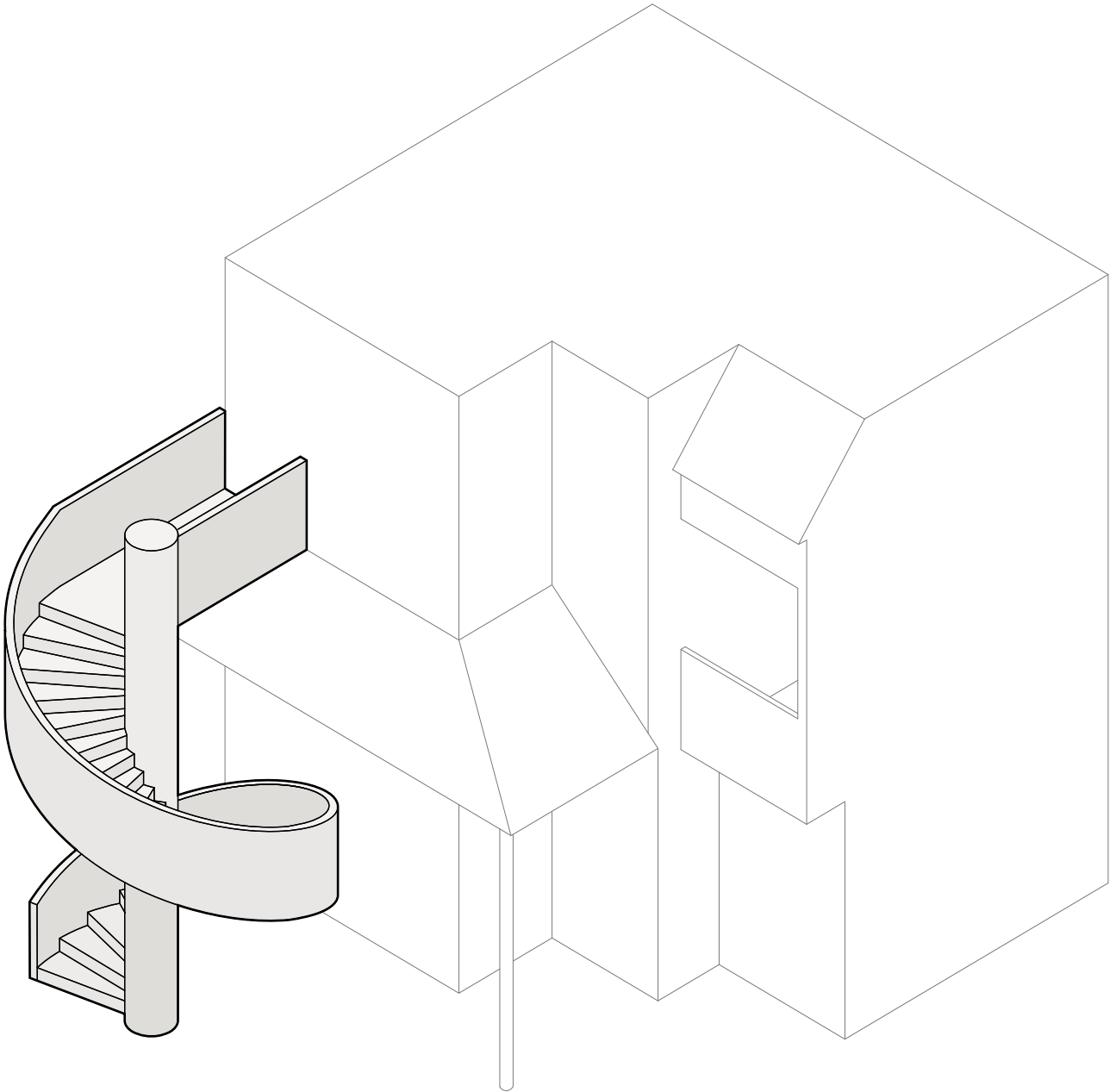

The Full Spiral

Stairs

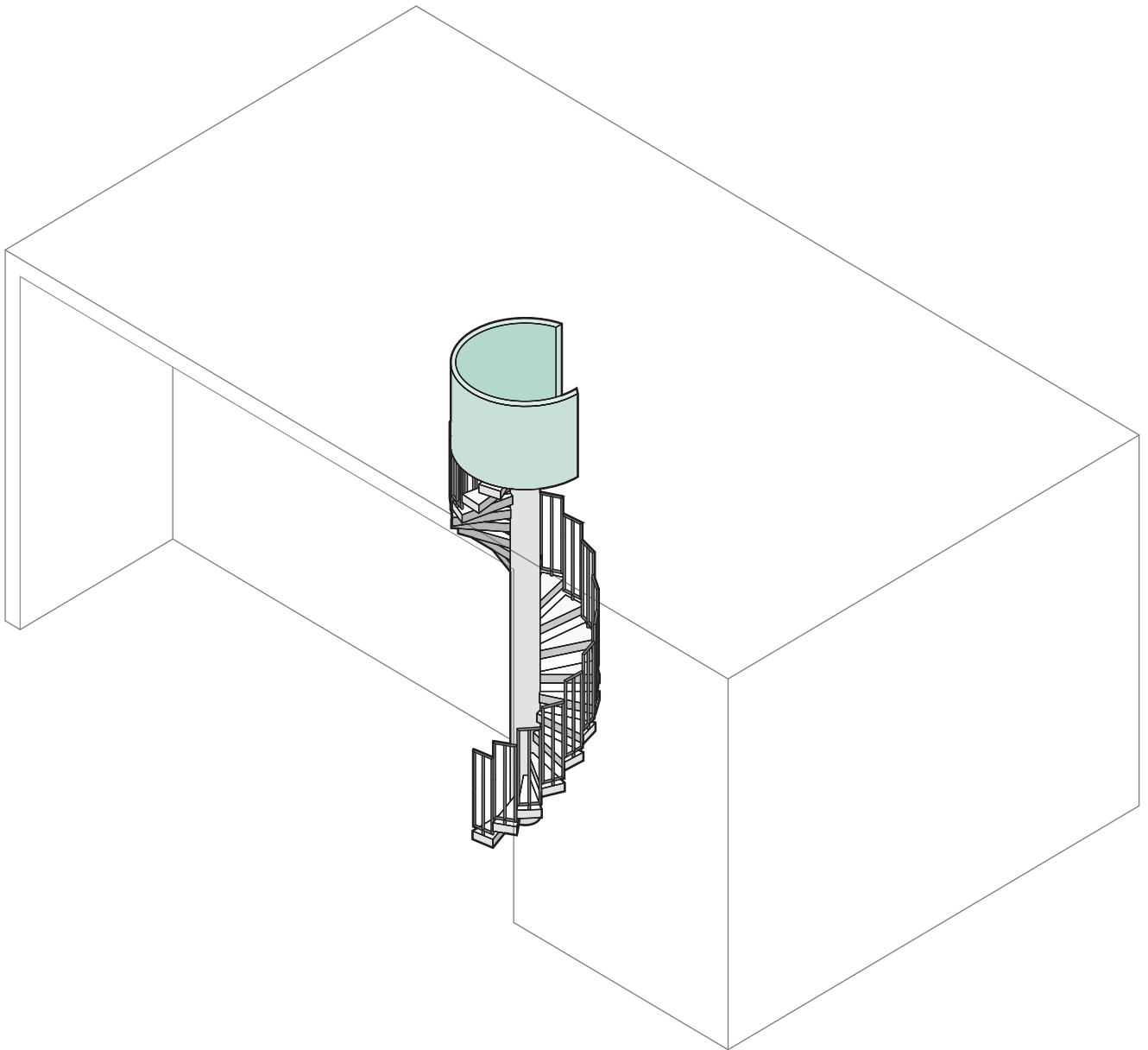

The Full Spiral

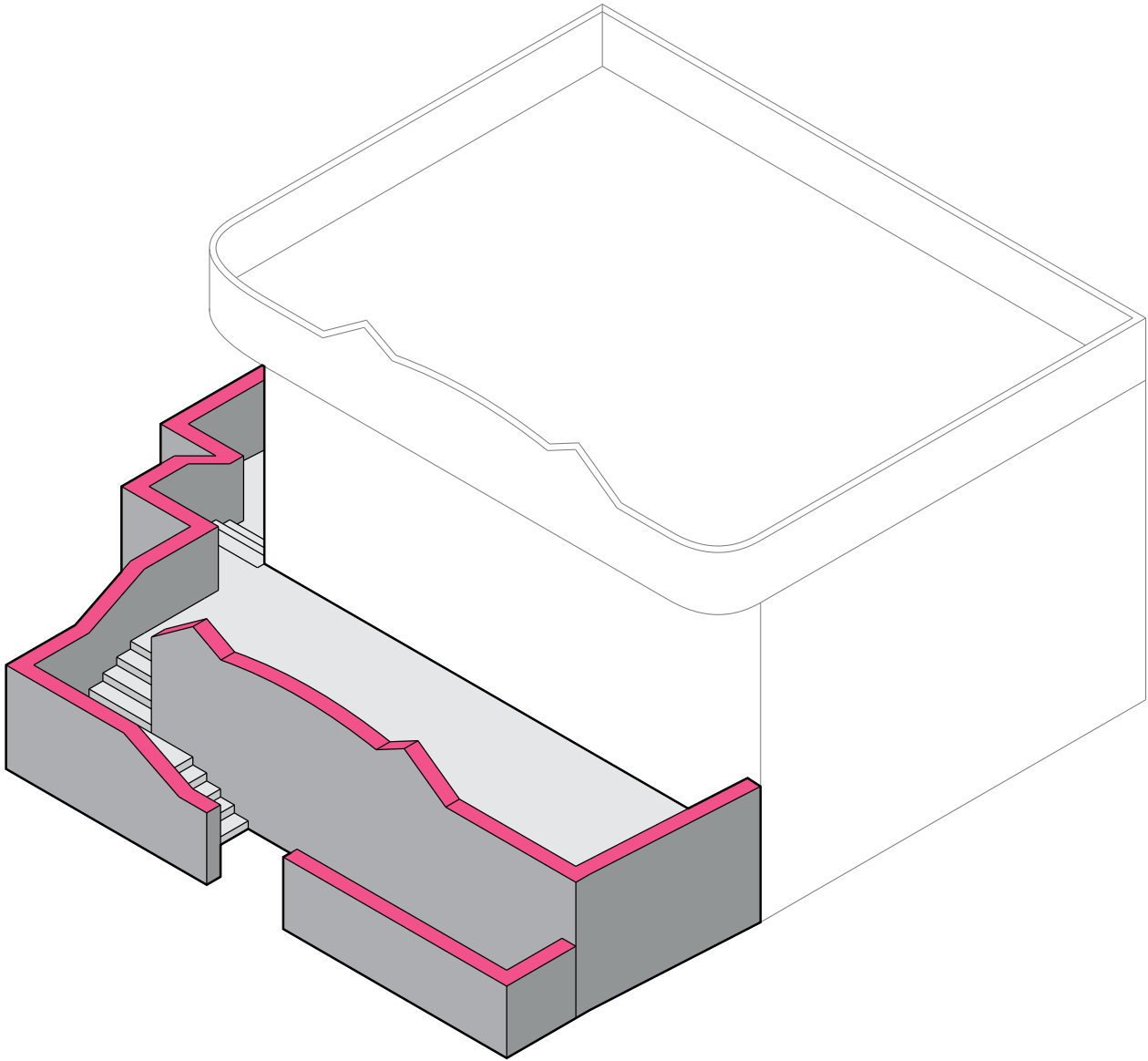

Some Kind of Symmetry

Stairs

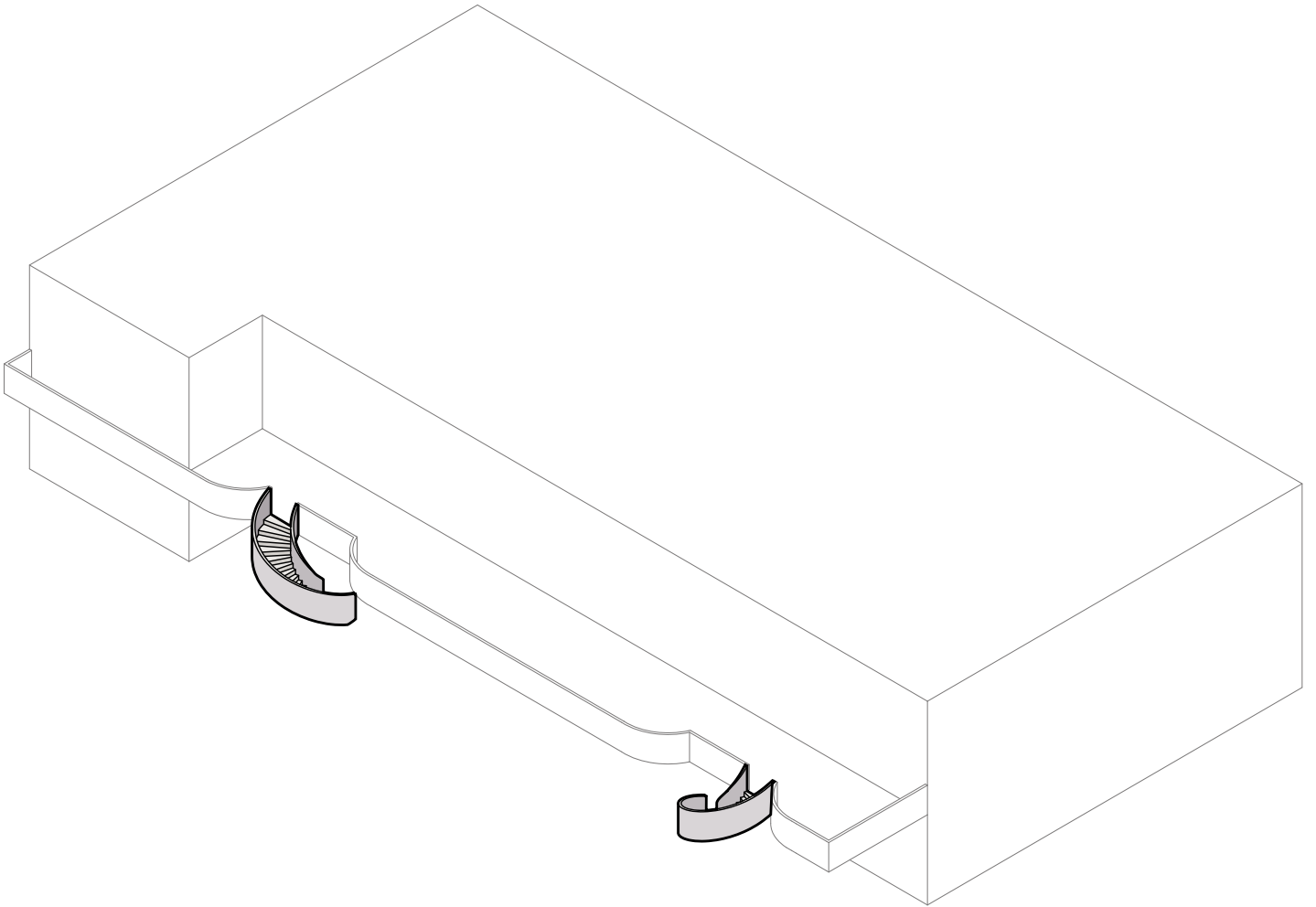

Some Kind of Symmetry

Fence, Gate, & Balustrade

Dhvani Doshi, Shauneil Williams,
Tatia Buziashvili, Yunji Seong

Fence, Gate, & Balustrade



Stack

Fence, Gate, & Balustrade



Stack

Fence, Gate, & Balustrade



Cast

Fence, Gate, & Balustrade



Cast

Fence, Gate, & Balustrade

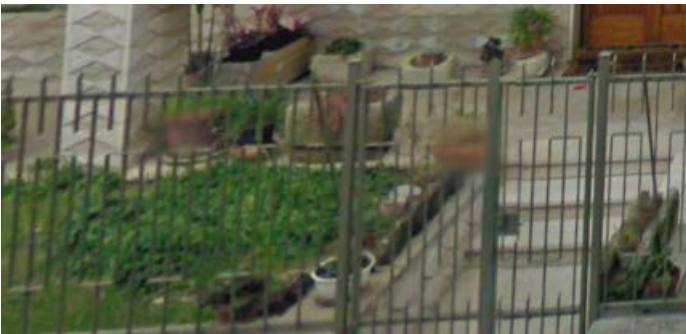

Weld

Fence, Gate, & Balustrade

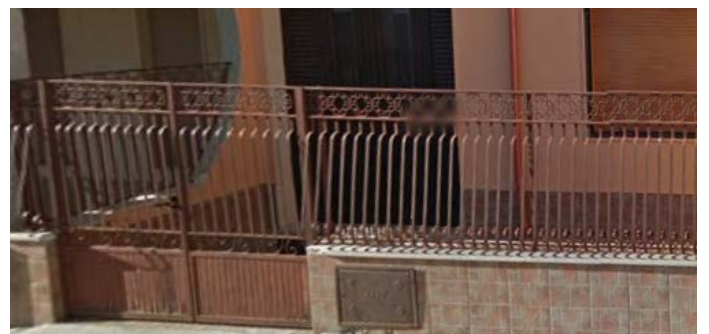
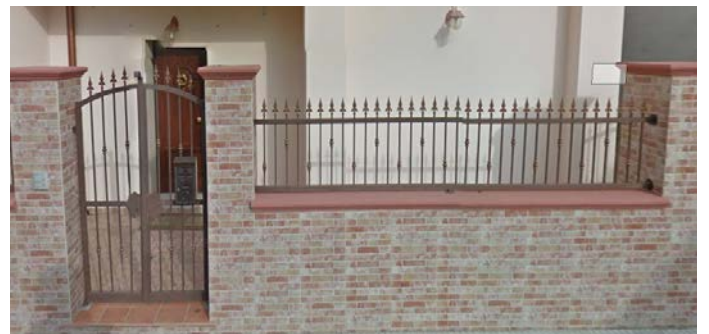
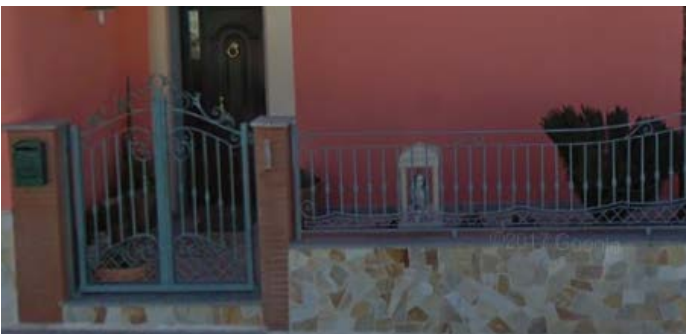

Weld

Fence, Gate, & Balustrade

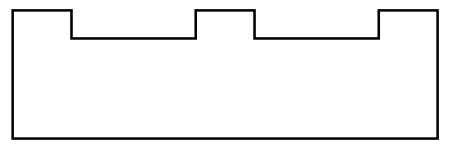
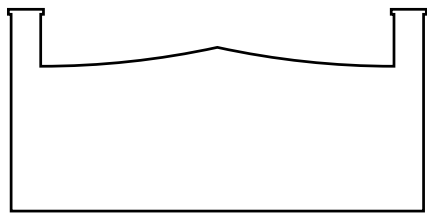
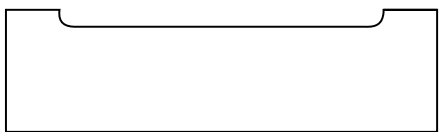
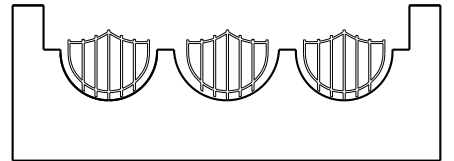
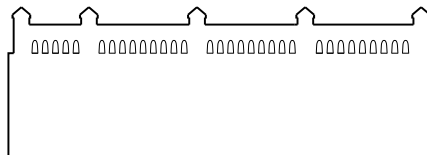
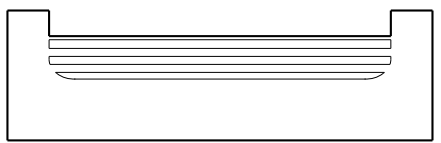
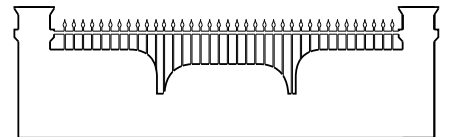
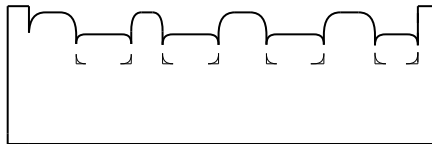
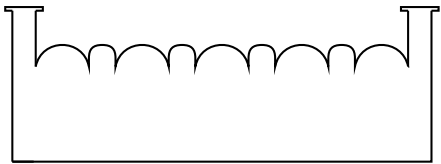
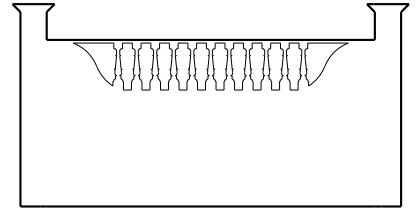
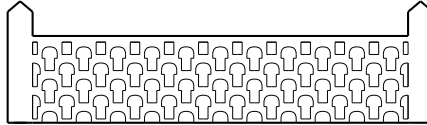
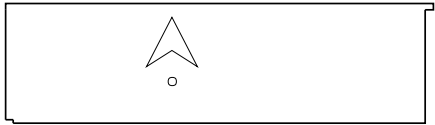
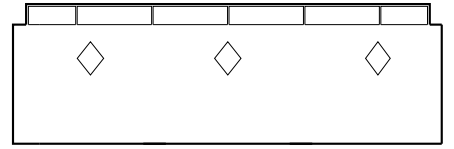
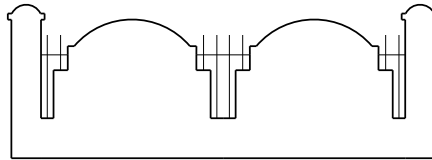
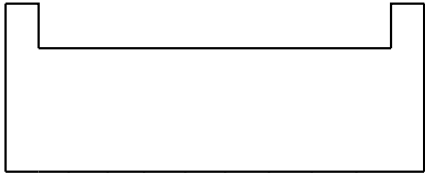
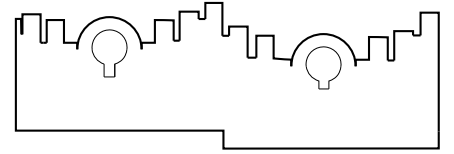
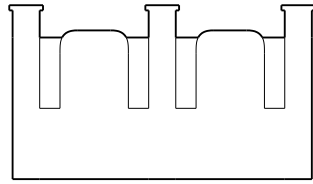
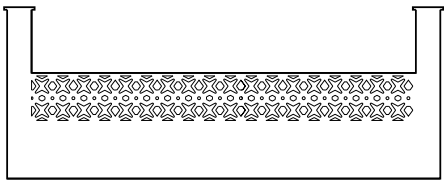

Select

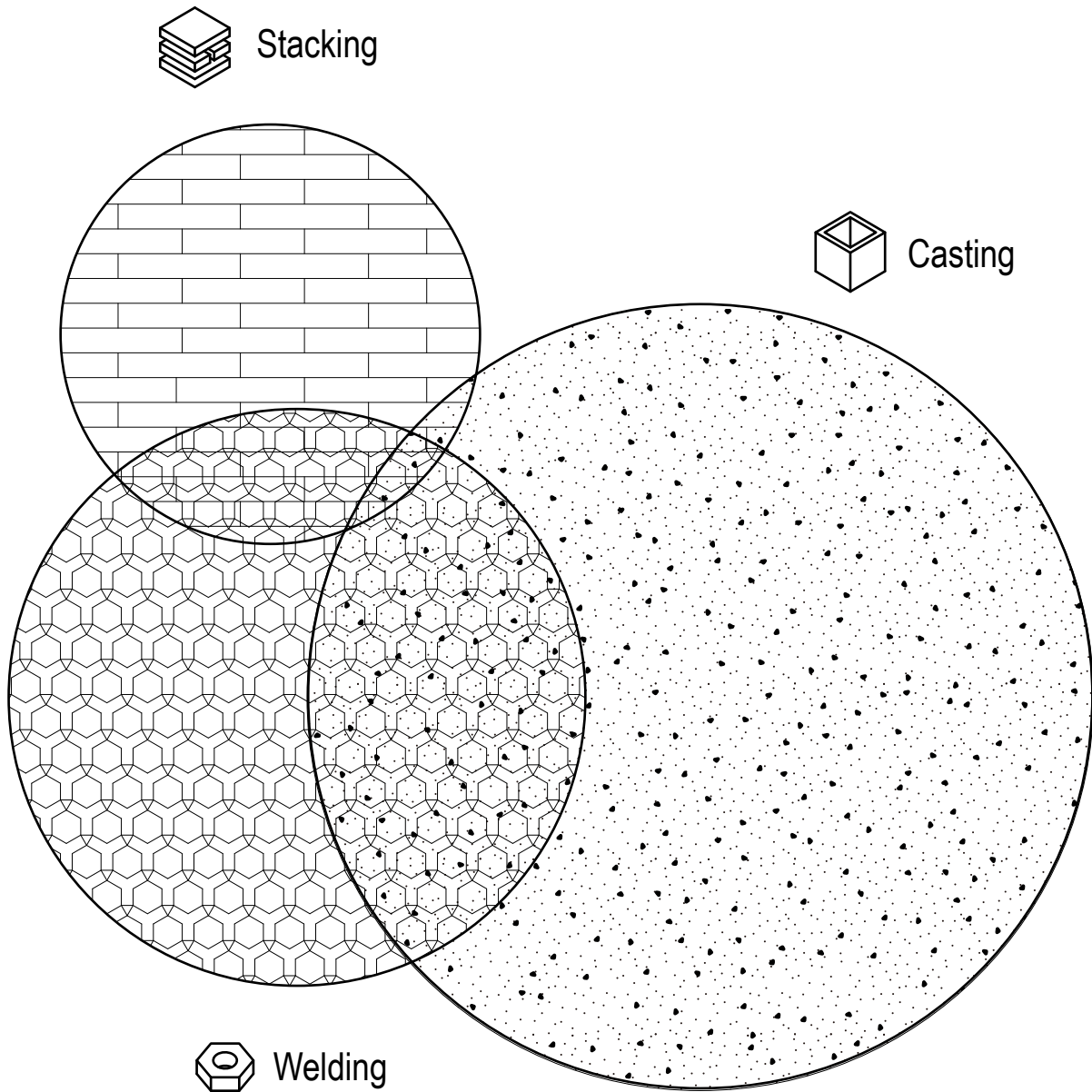

Venn Diagram

Fence, Gate, & Balustrade

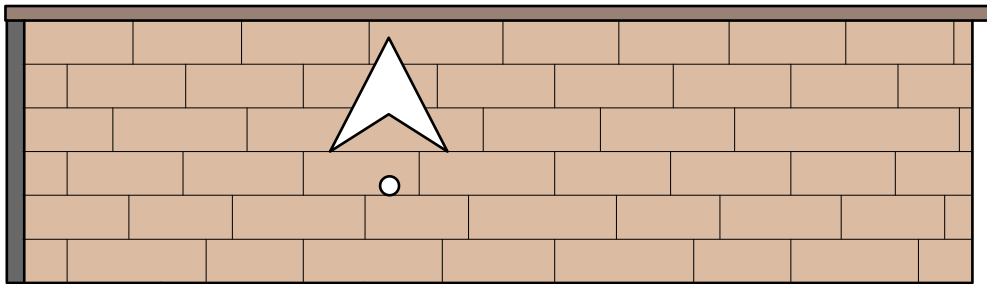
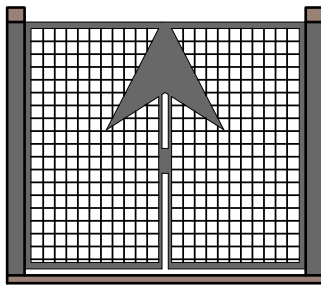

Stacking



Welding

Isolated

Fence, Gate, & Balustrade

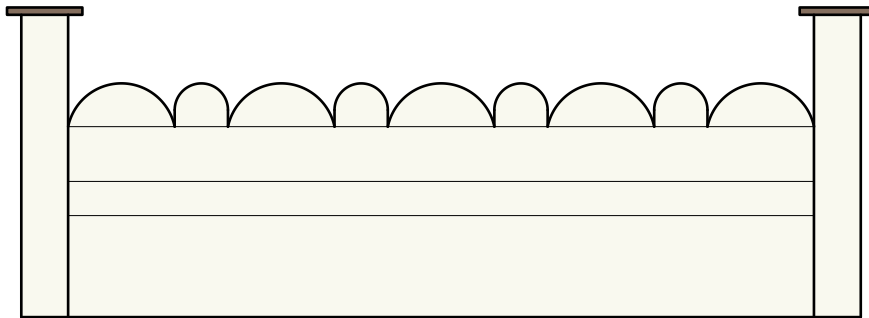
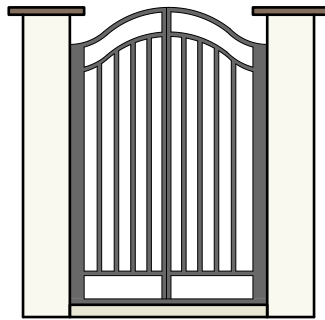

Isolated

Fence, Gate, & Balustrade

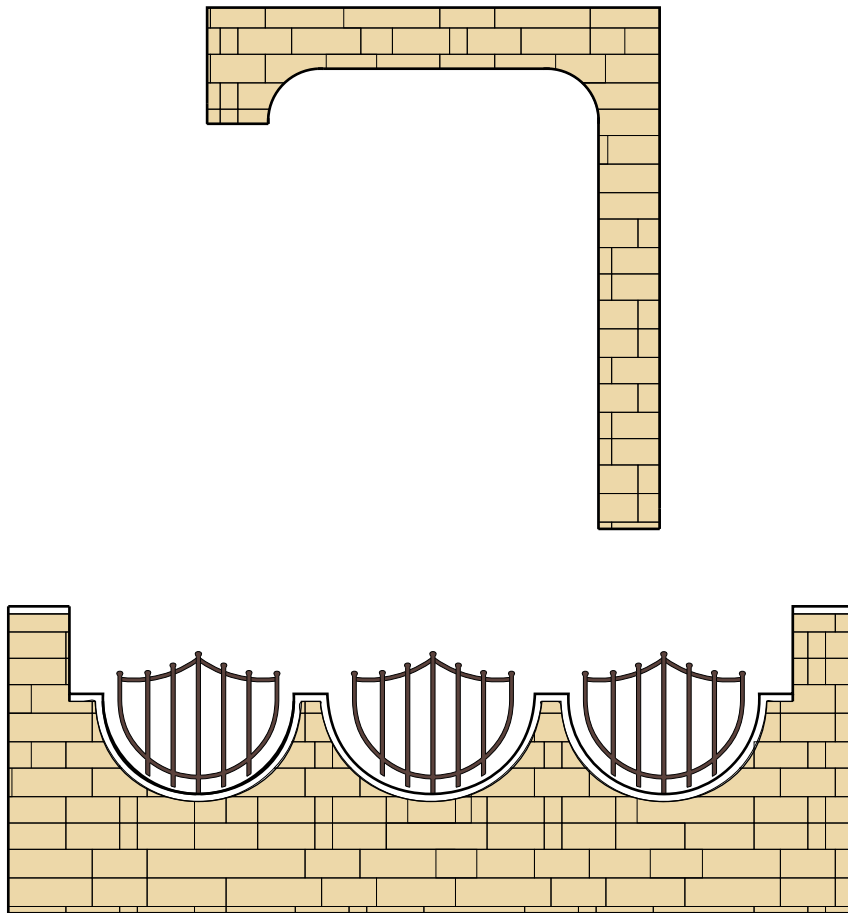

Stacking



Welding

Isolated

Fence, Gate, & Balustrade

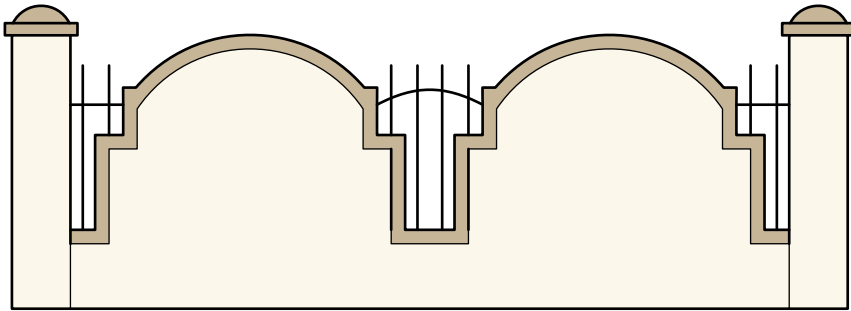
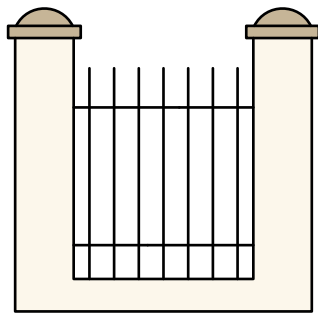

Casting



Welding

Isolated

Fence, Gate, & Balustrade

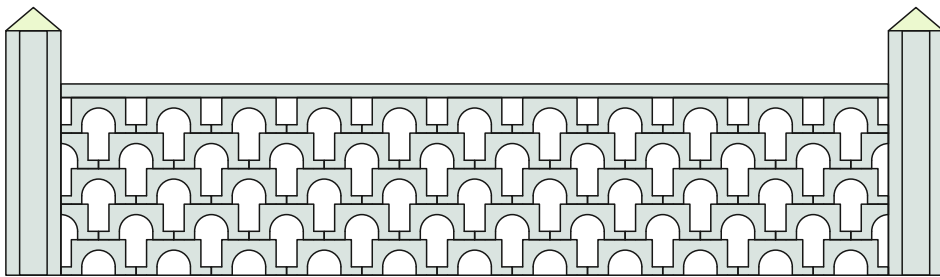
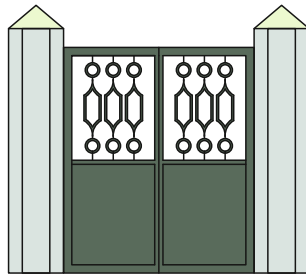

Stacking

Isolated

Fence, Gate, & Balustrade

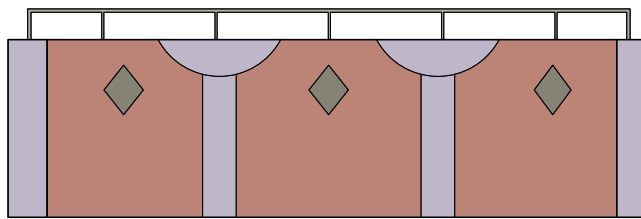
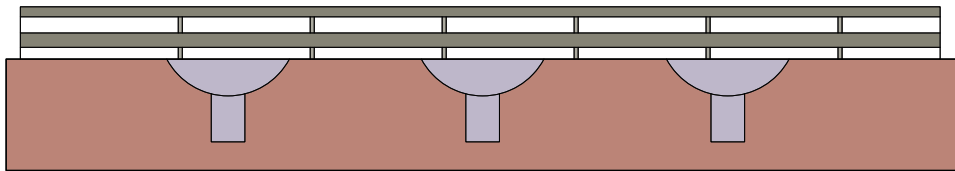
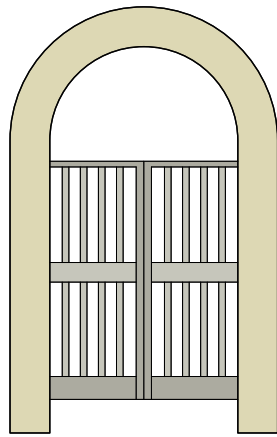

Casting



Welding

Related

Fence, Gate, & Balustrade

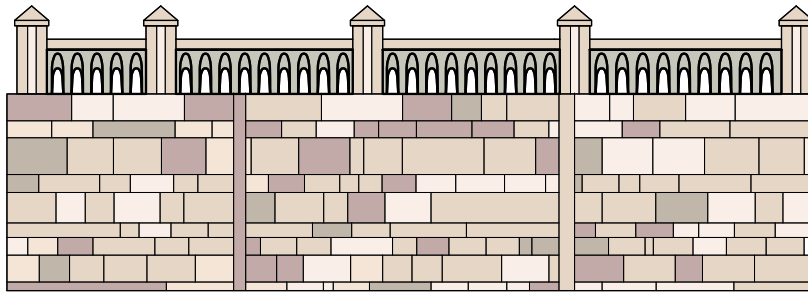
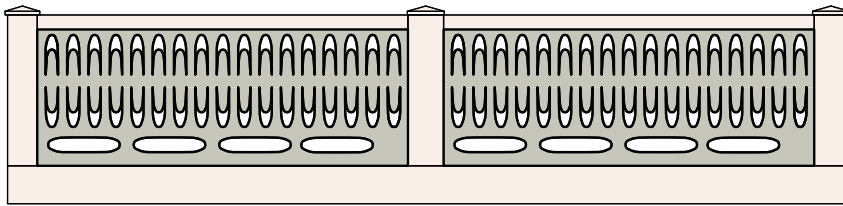
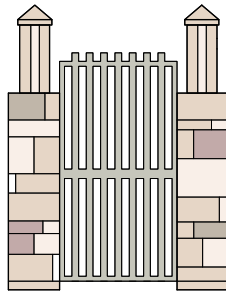

Stacking



Casting

Related

Fence, Gate, & Balustrade

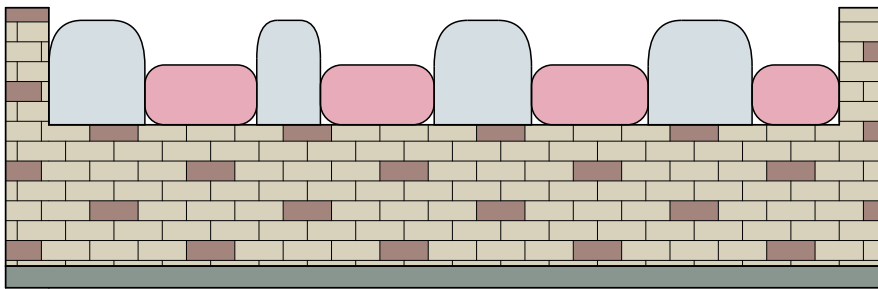
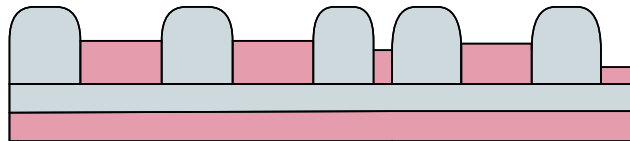
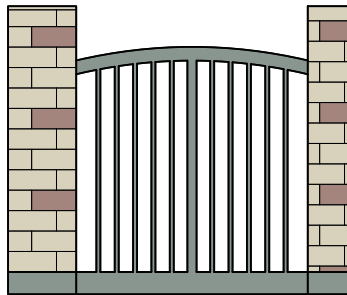

Stacking



Casting

Related

Fence, Gate, & Balustrade

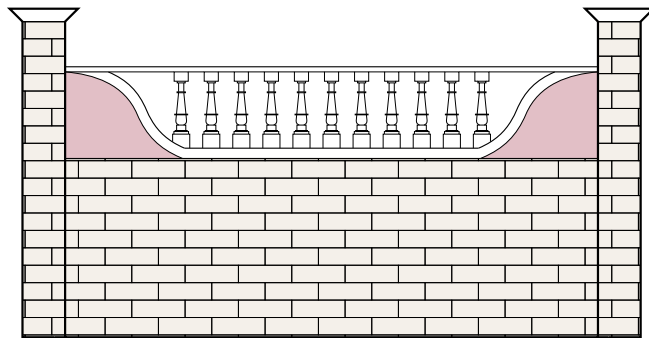
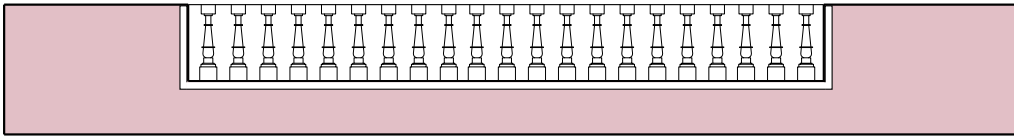
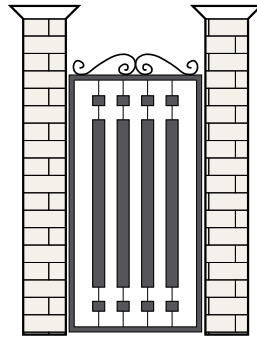

Stacking



Casting

Related

Fence, Gate, & Balustrade

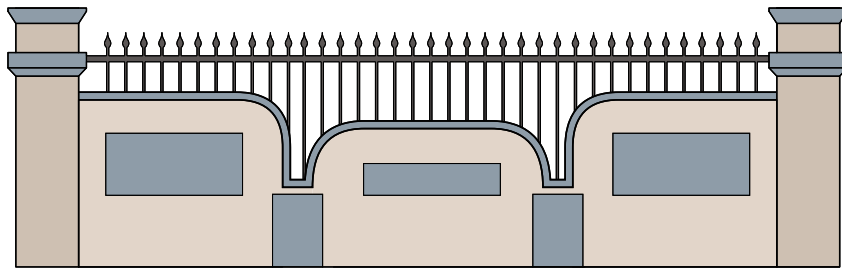
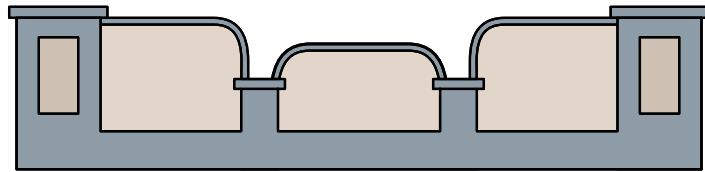
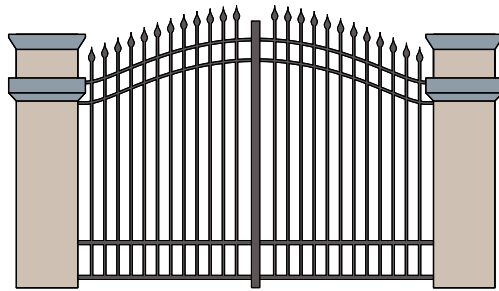

Casting



Welding

Related

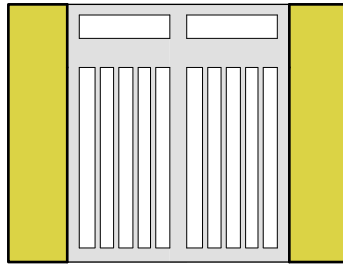

Casting

Unrelated

Fence, Gate, & Balustrade

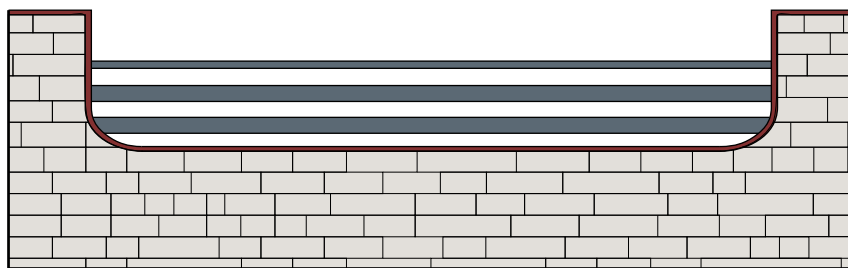
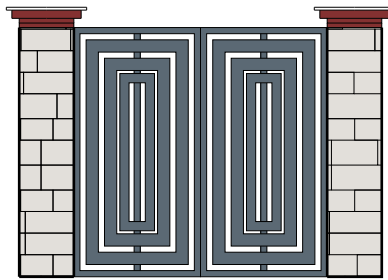

Stacking



Casting



Welding

Unrelated

Fence, Gate, & Balustrade

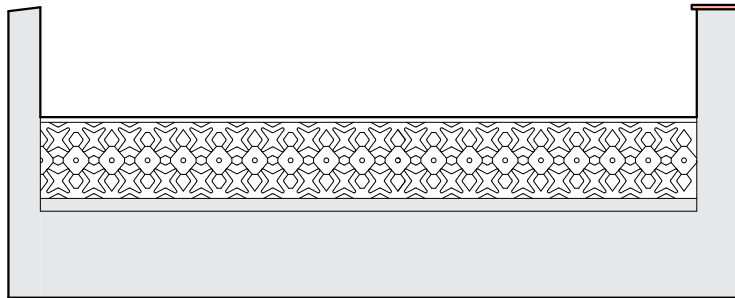
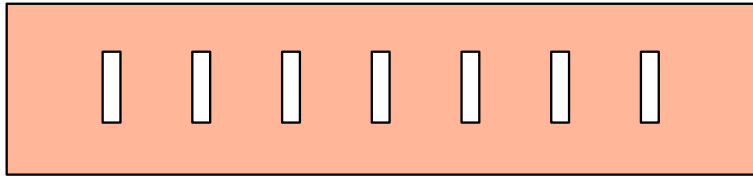
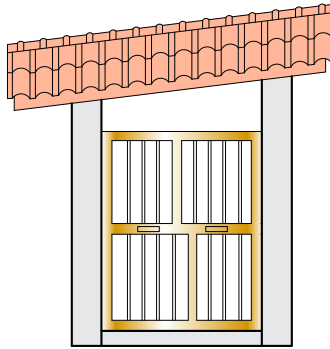

Casting



Welding

Unrelated

Fence, Gate, & Balustrade

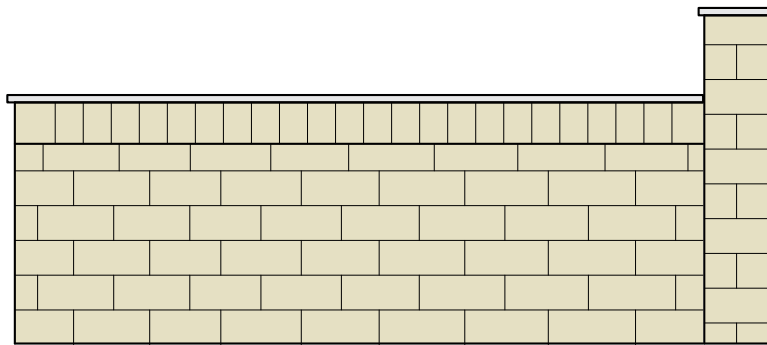
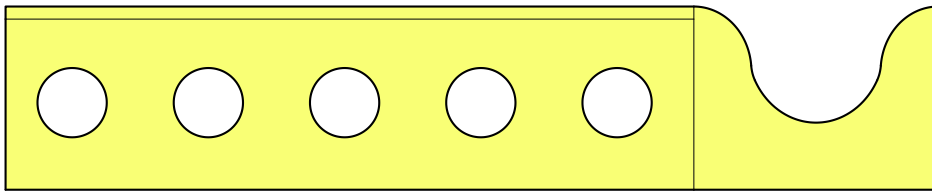
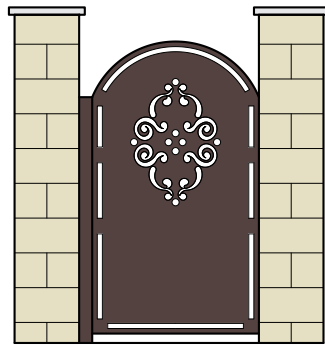

Stacking



Casting

Unrelated

Fence, Gate, & Balustrade

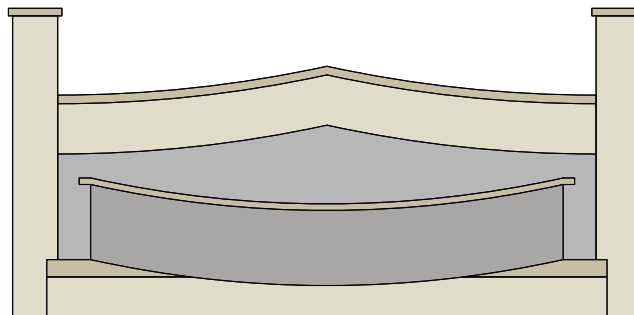
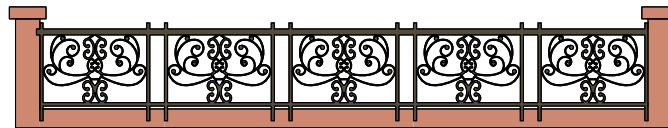
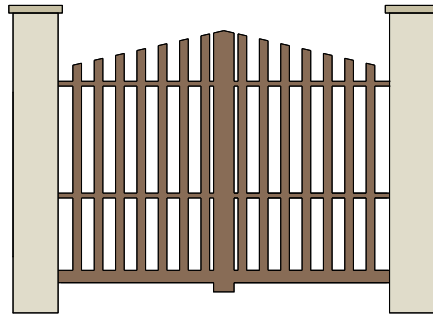

Casting



Welding

Unrelated

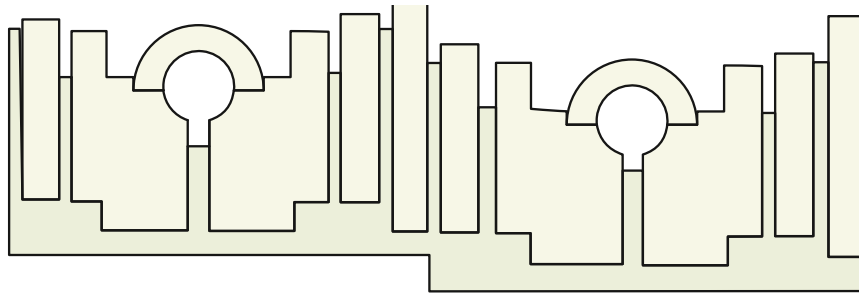
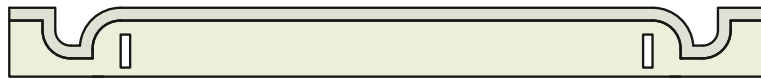
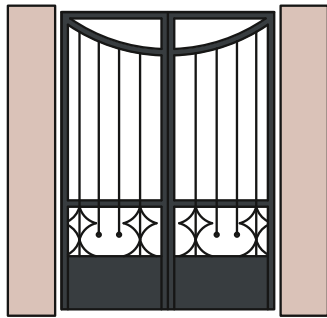

Casting

Unrelated

Fence, Gate, & Balustrade

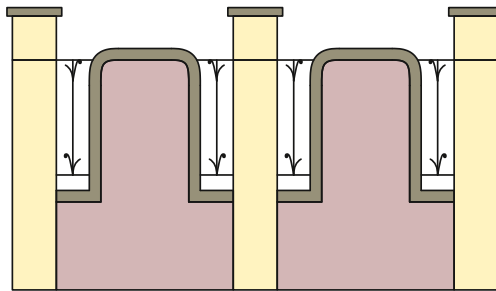
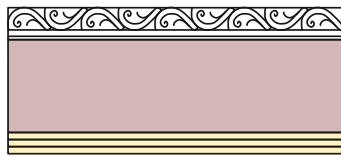
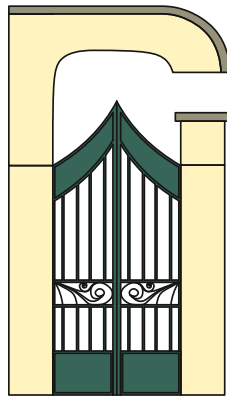

Casting



Welding

Unrelated

Fence, Gate, & Balustrade

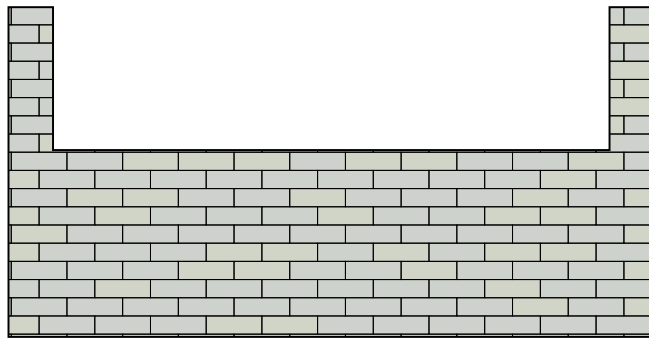
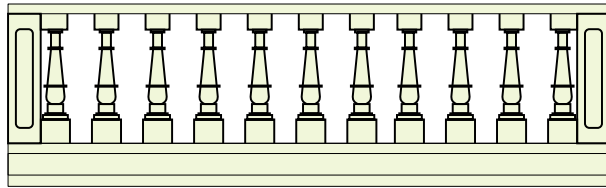
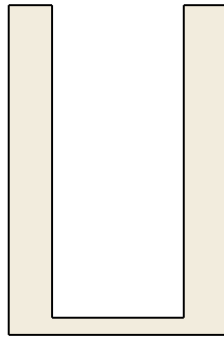

Unrelated

Moulding

Katrina Abad, Michele Pfleuger

Moulding

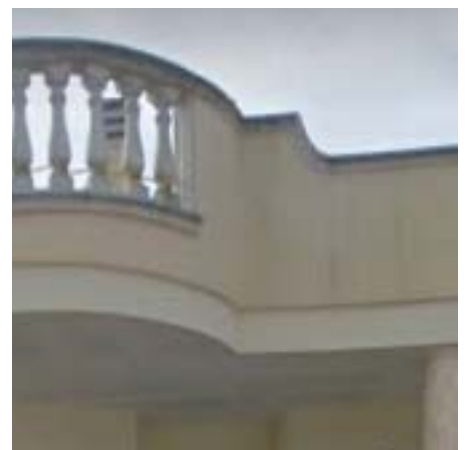
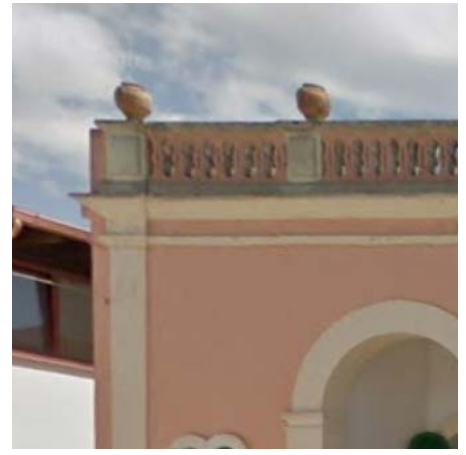

Extrusion

Moulding

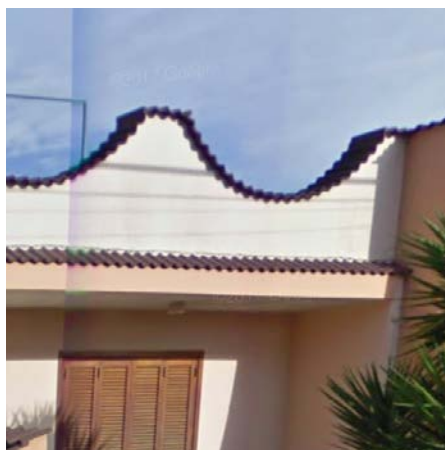

Application

Moulding

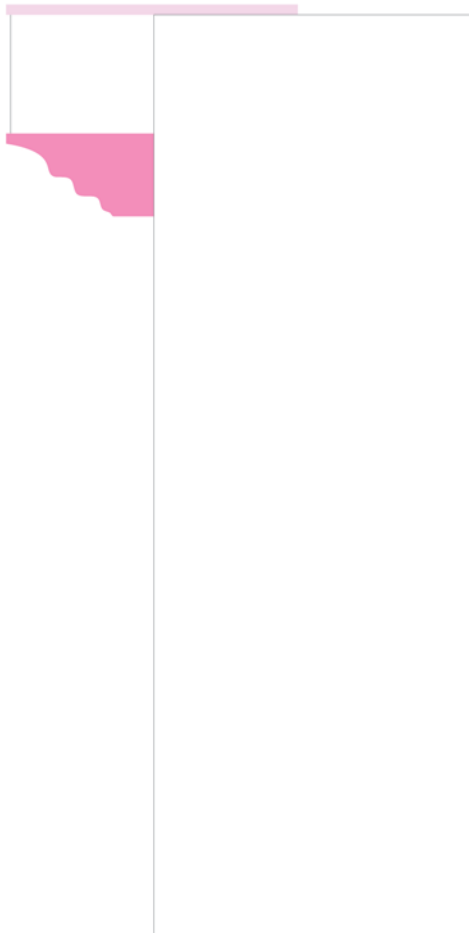
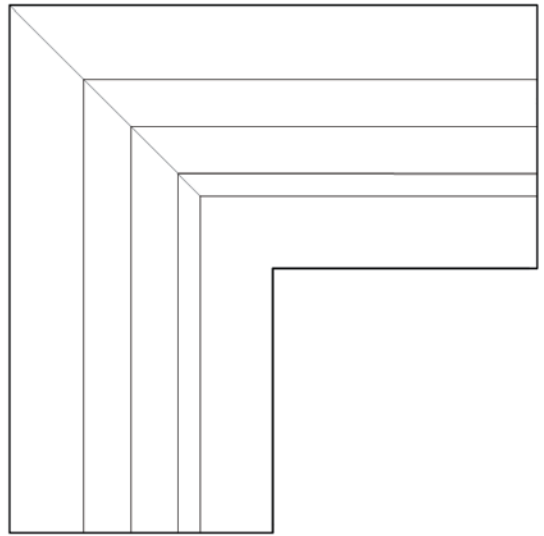
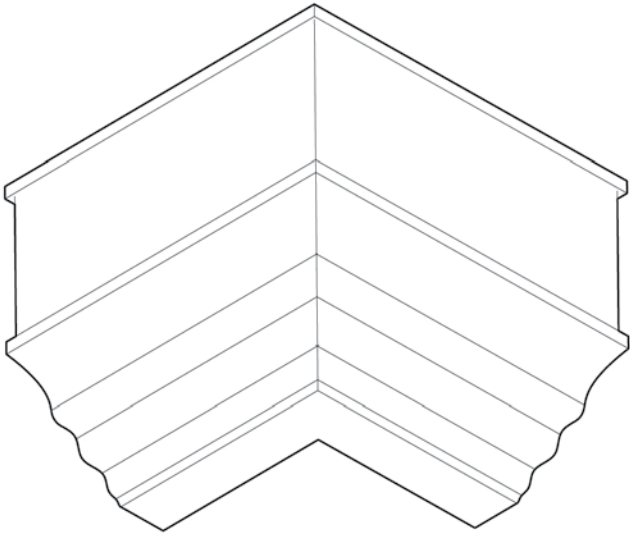

Altered Ogee

Moulding

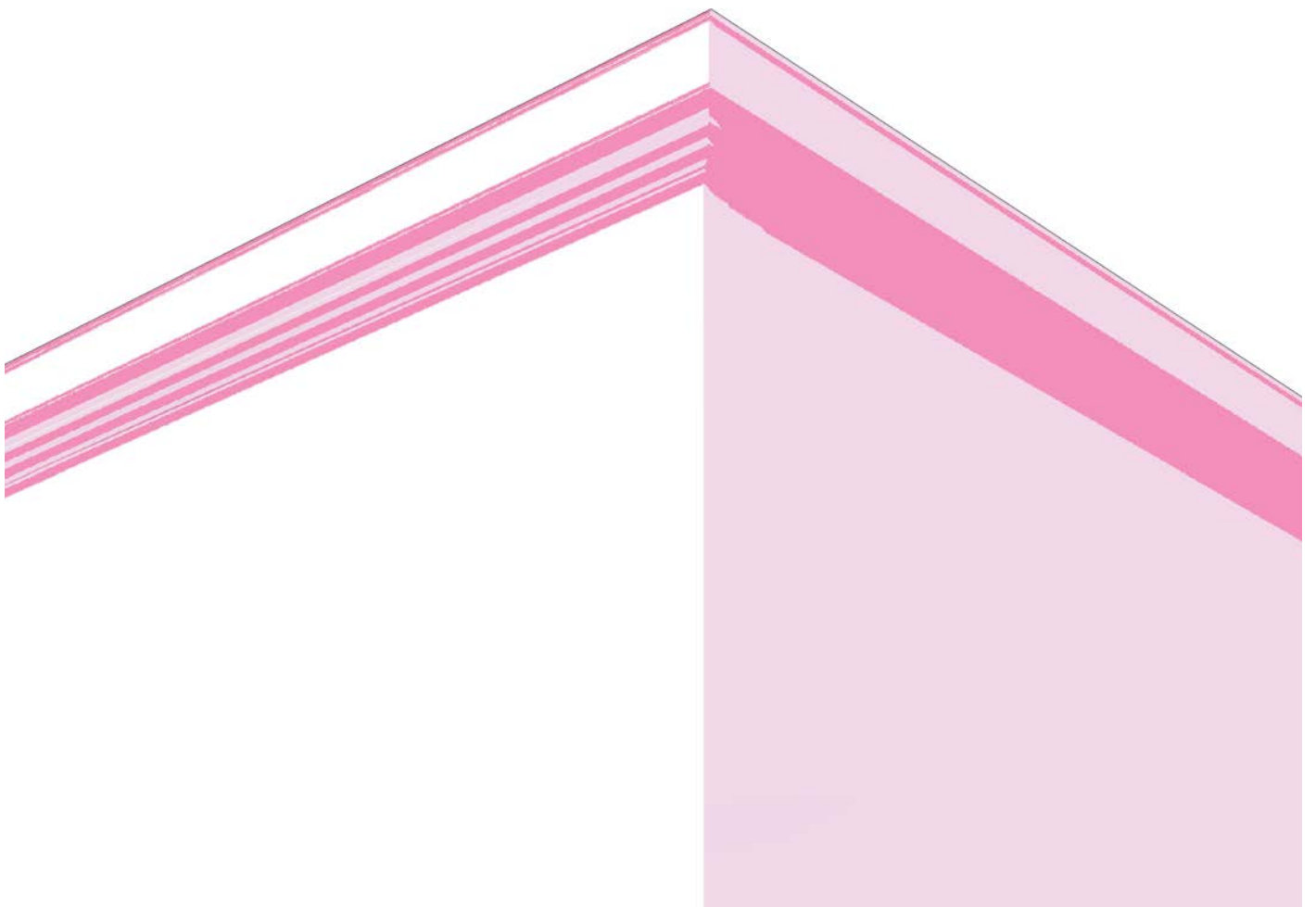

Altered Ogee

Moulding

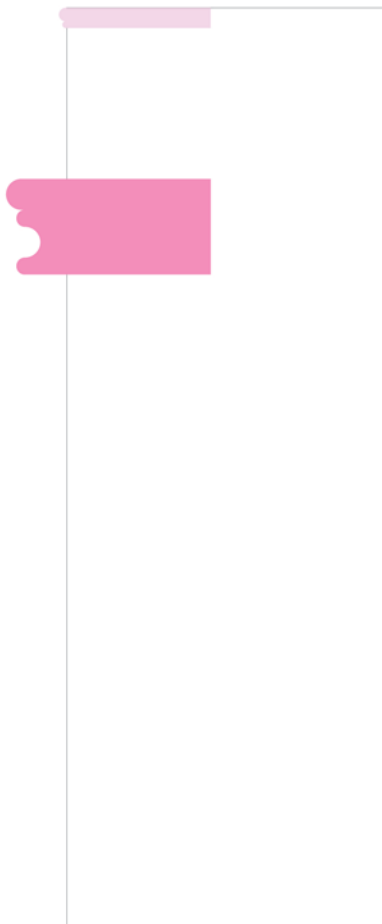
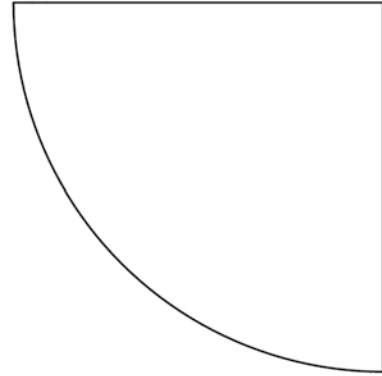
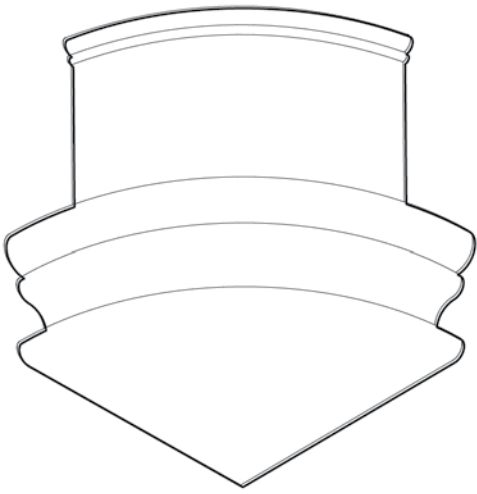

Round



Round

Moulding

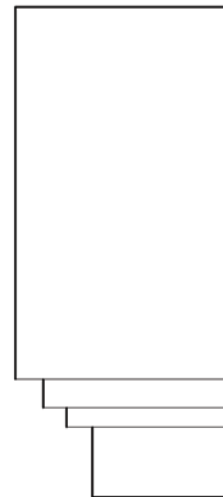
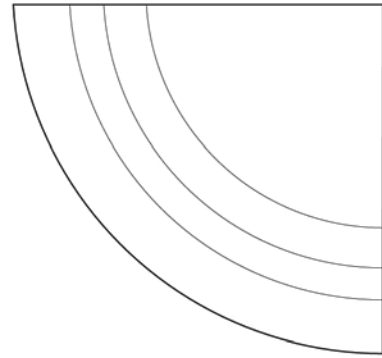
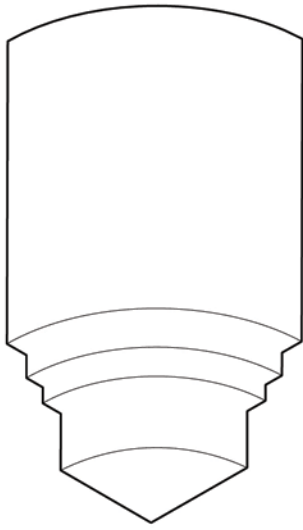

Subtractive



Subtractive

Moulding

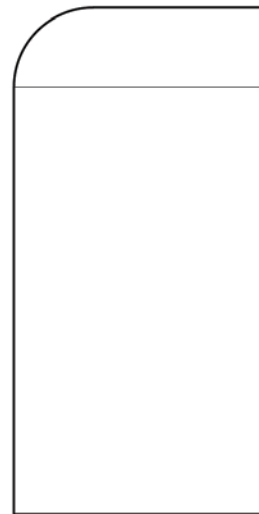
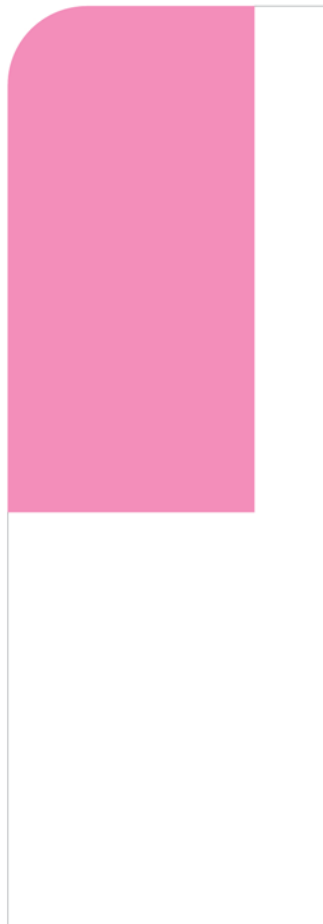
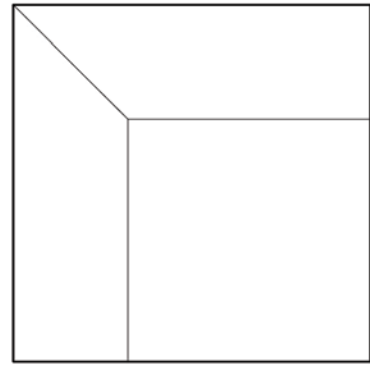
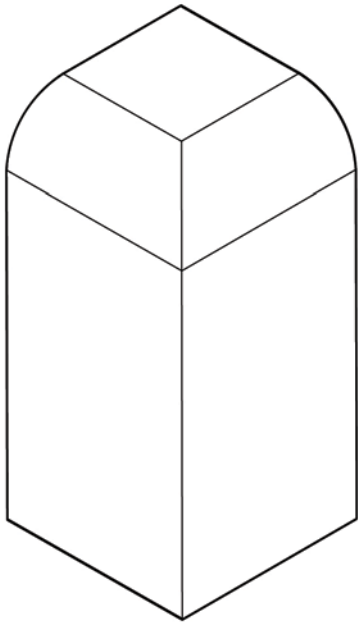

Fillet



Fillet

Moulding

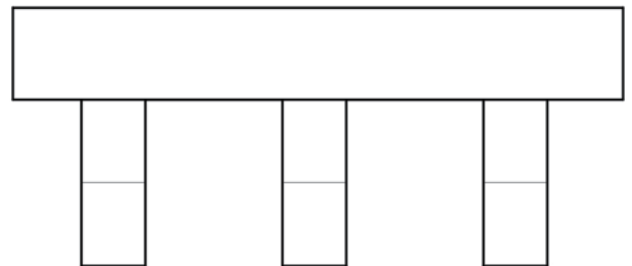
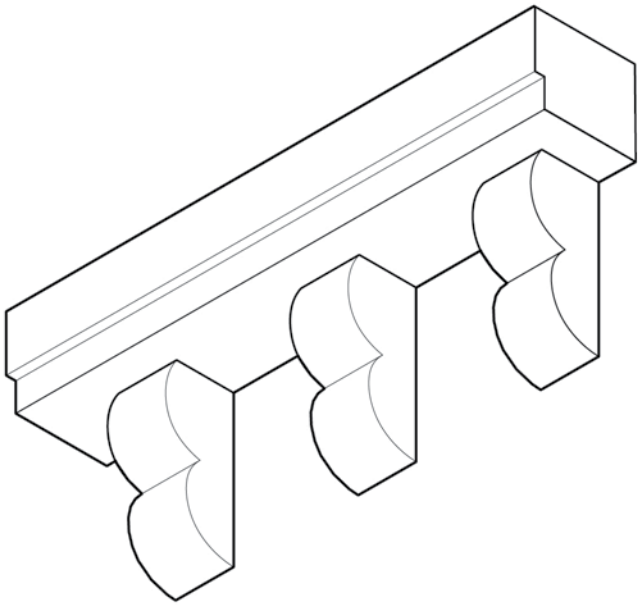

Bracket

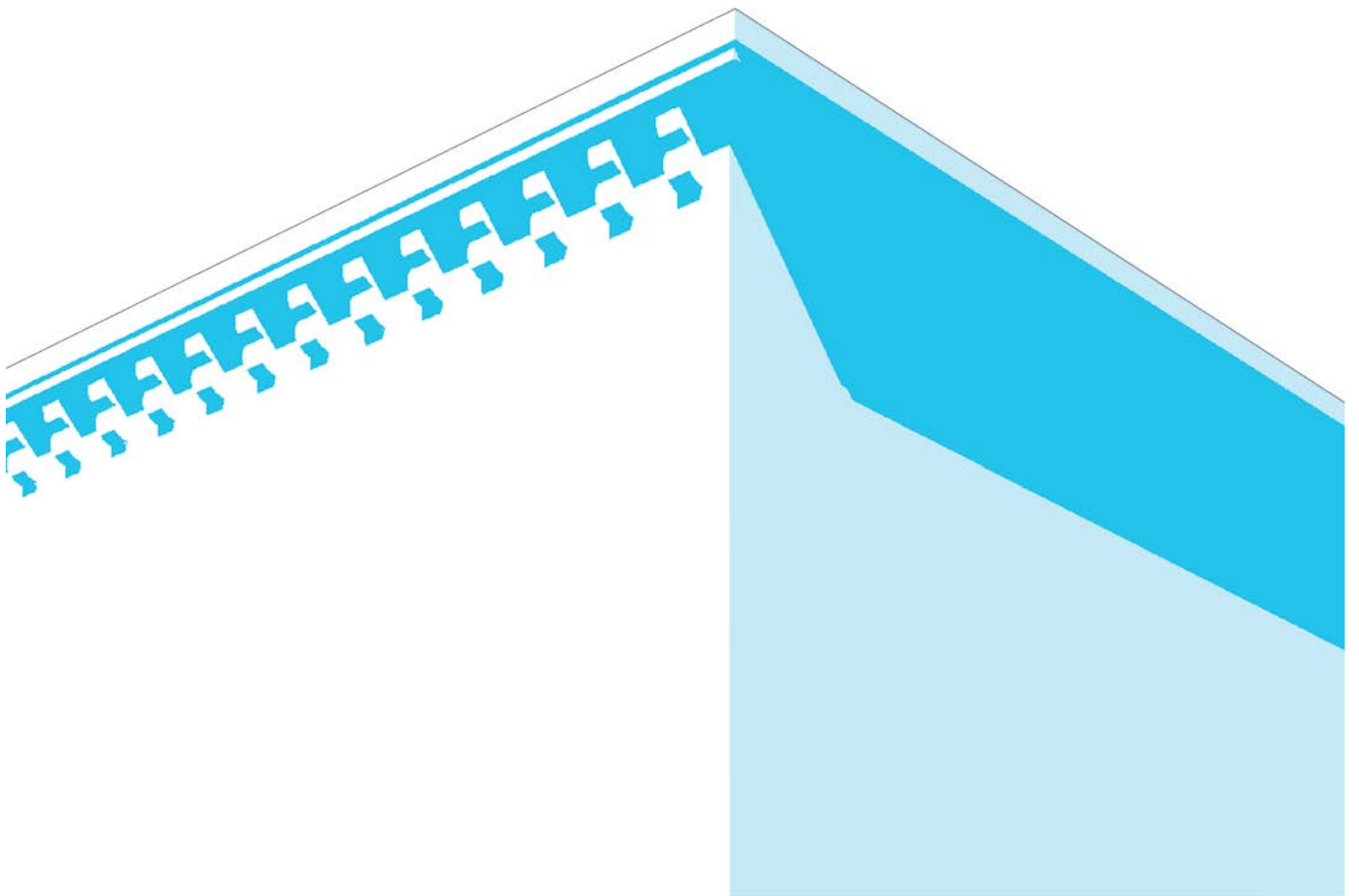

Bracket

Moulding

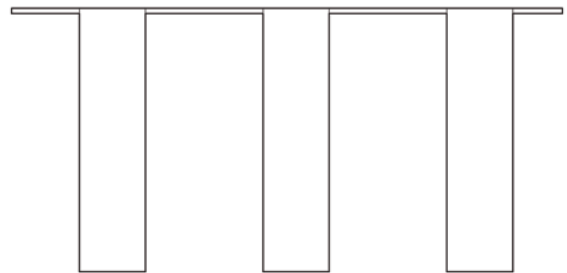
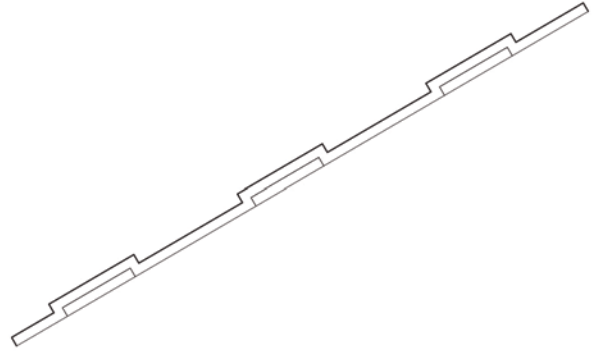
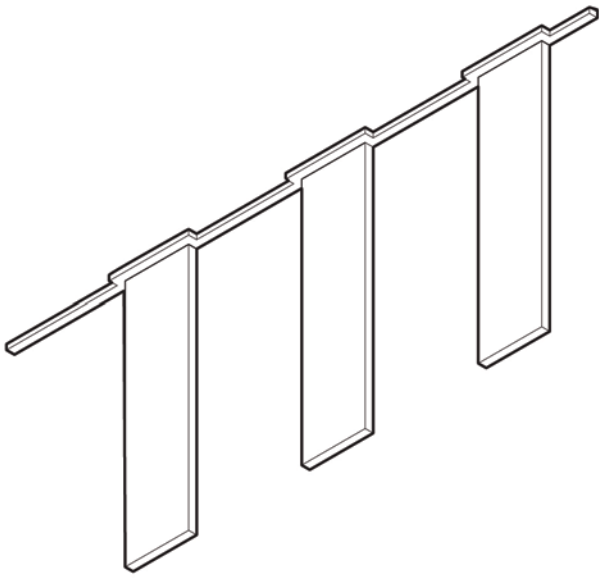

Dentil

Moulding

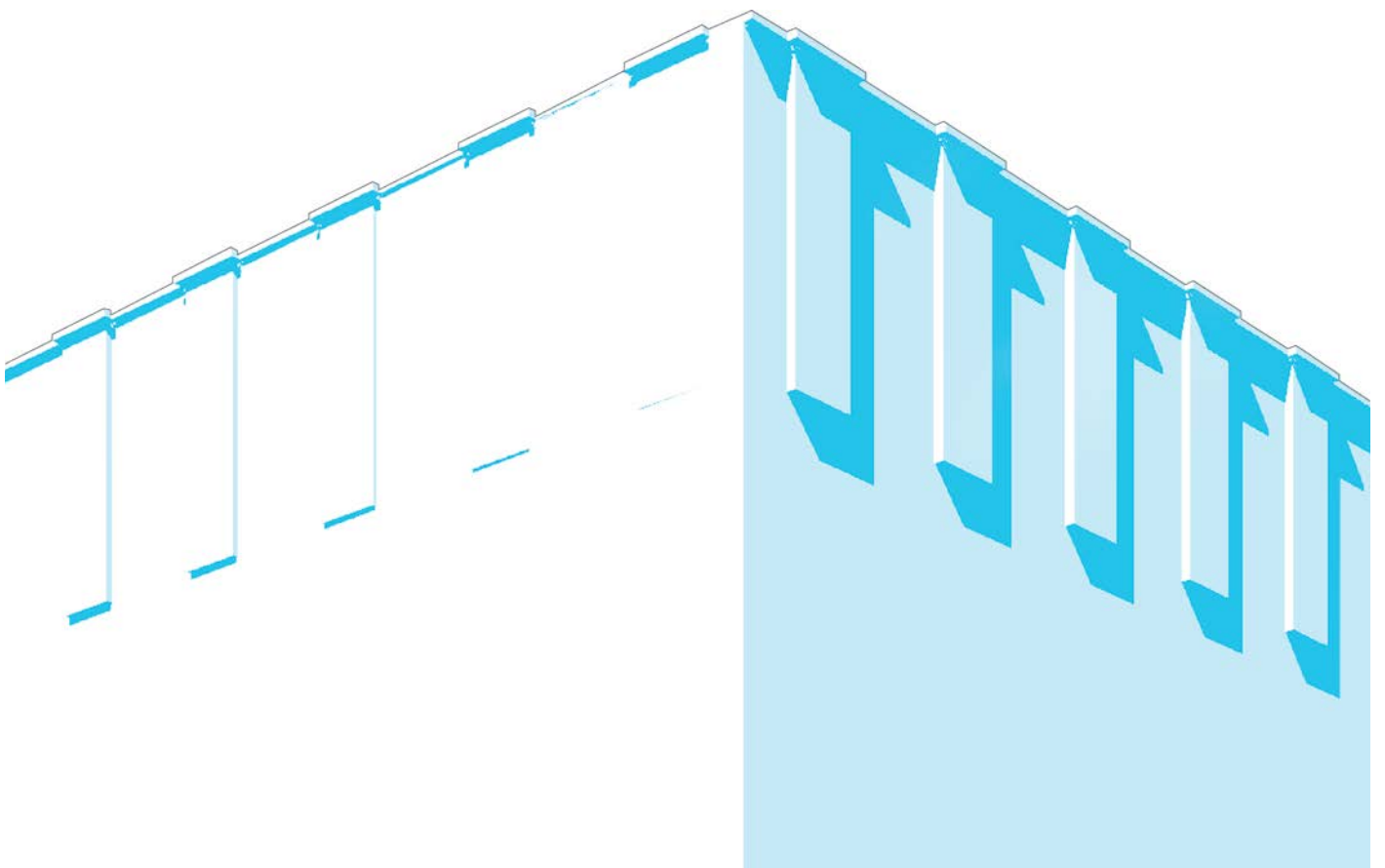

Dentil

Moulding

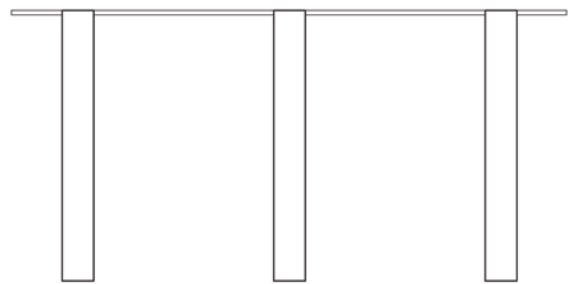
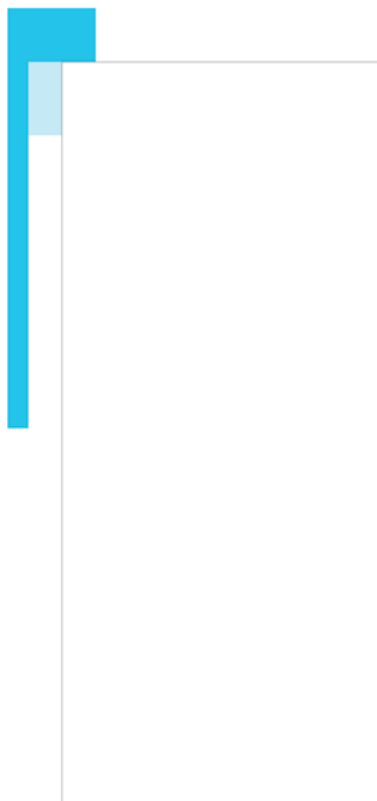
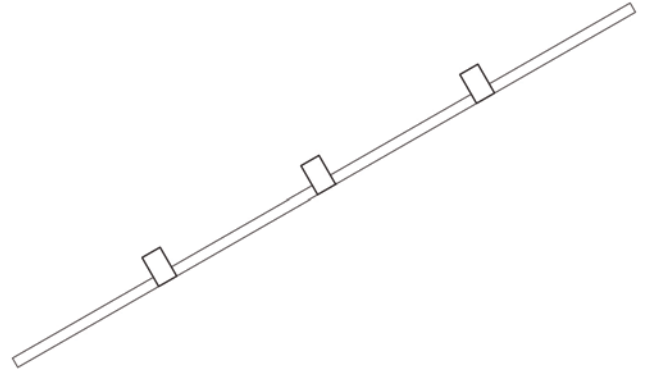
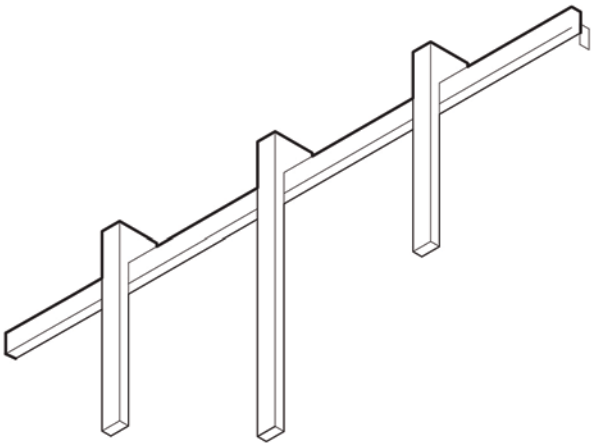

L

Moulding

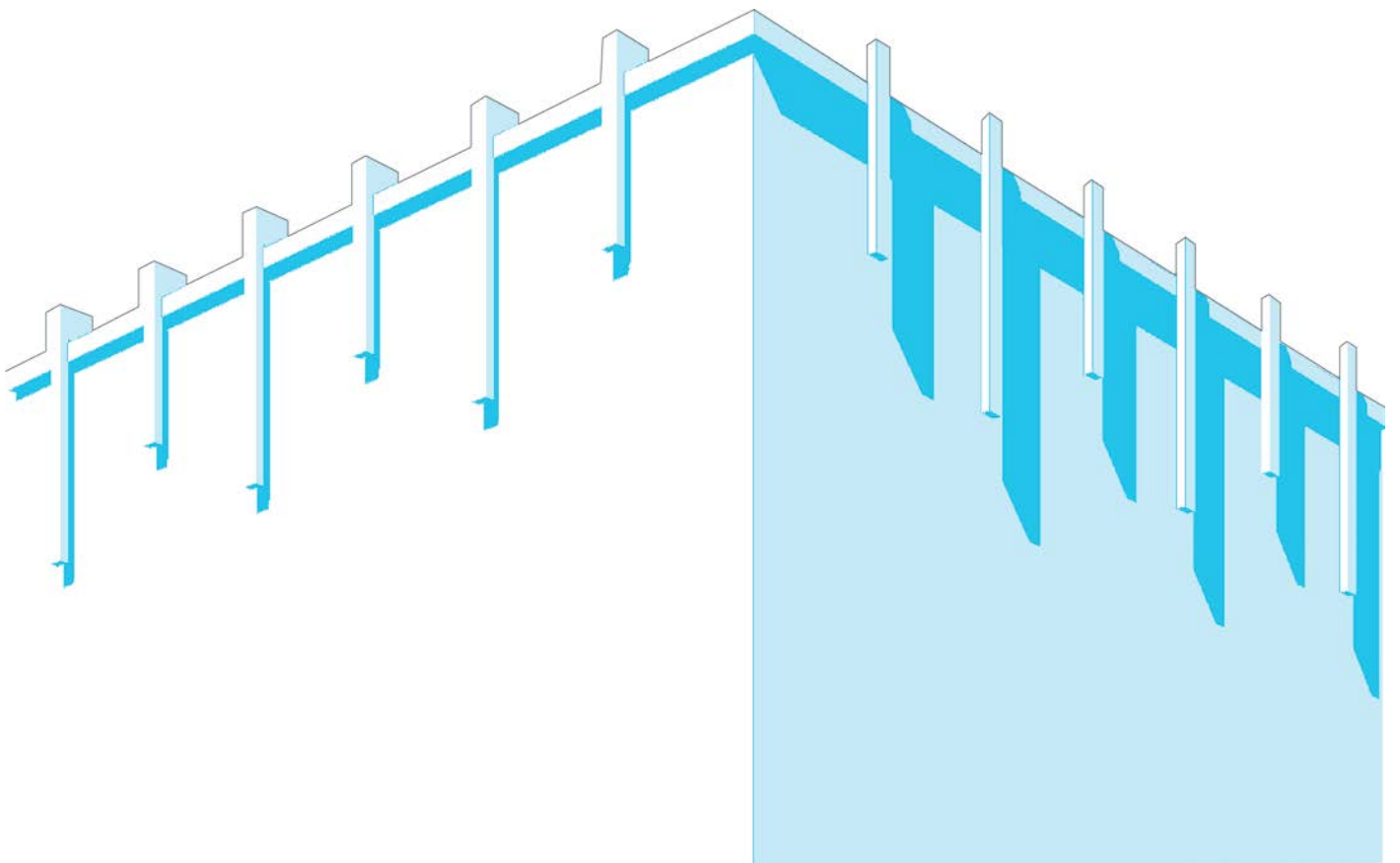

L

Moulding

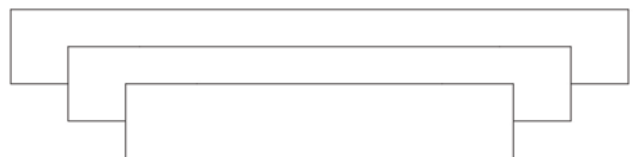
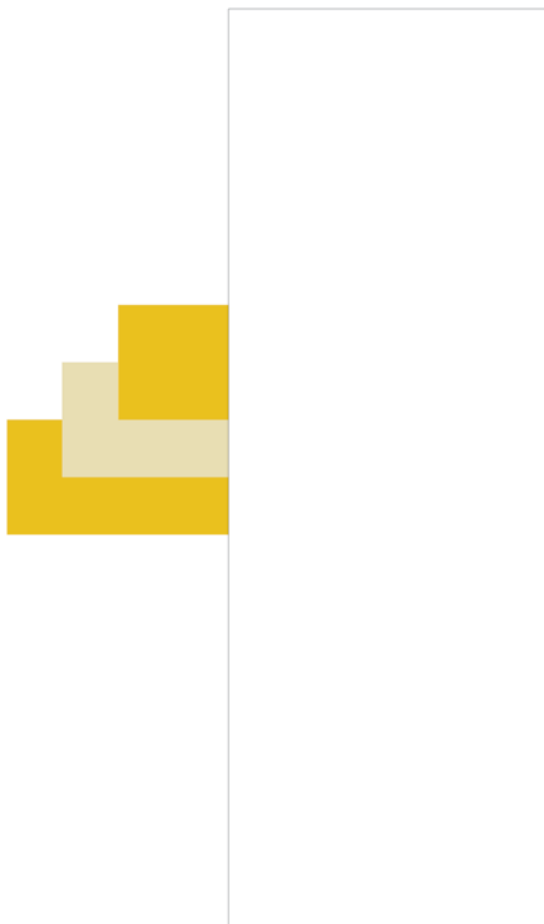
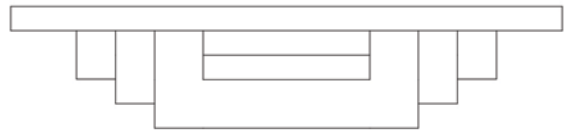
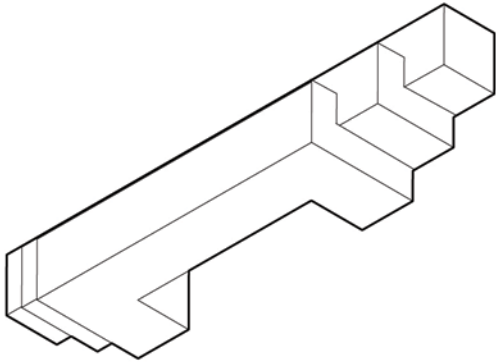

Stacked

Moulding

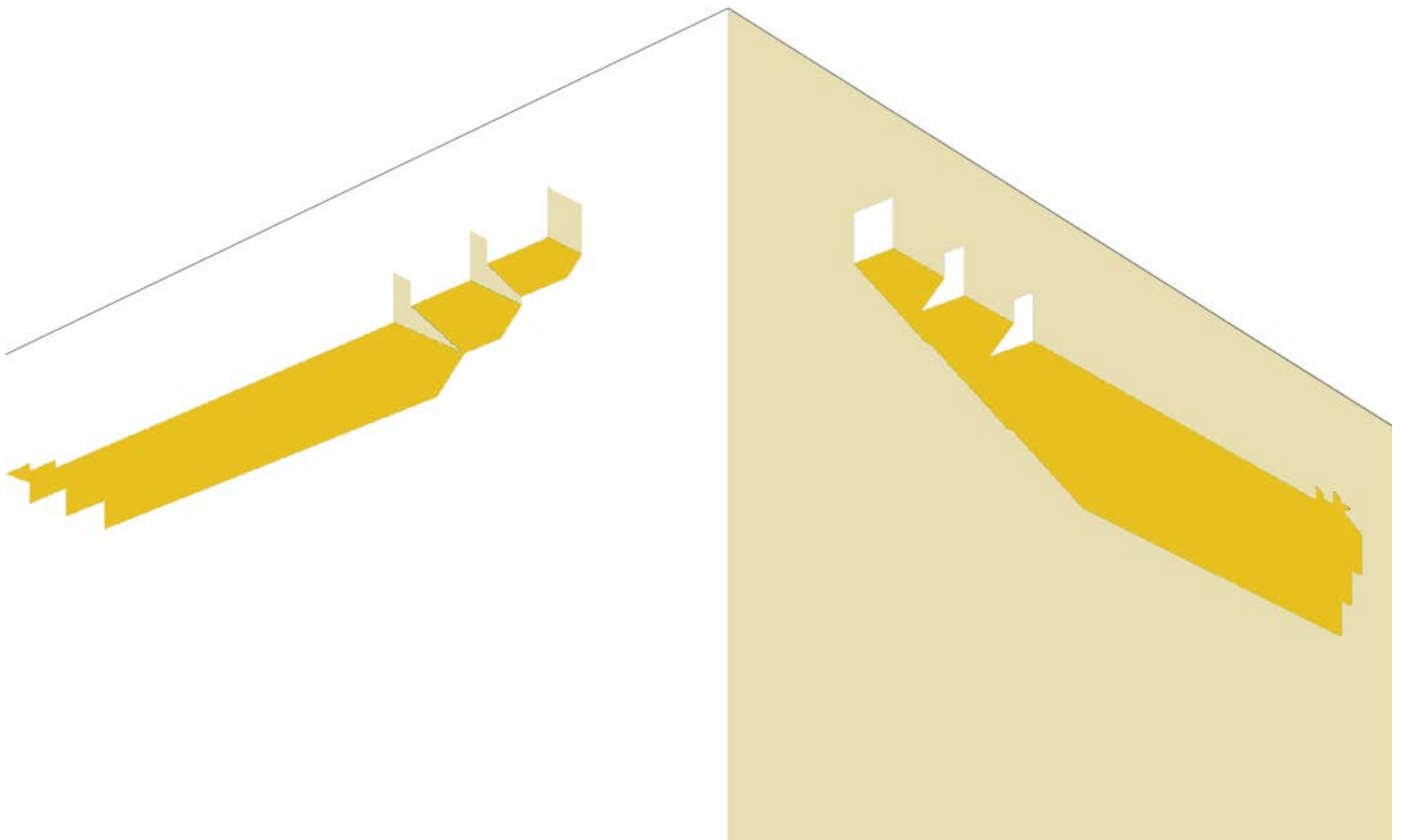

Stacked

Moulding

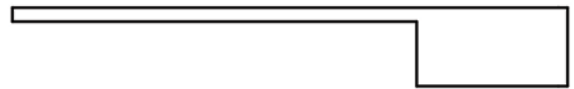
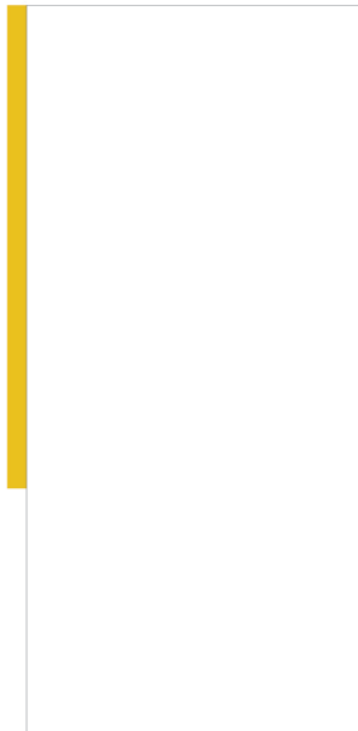
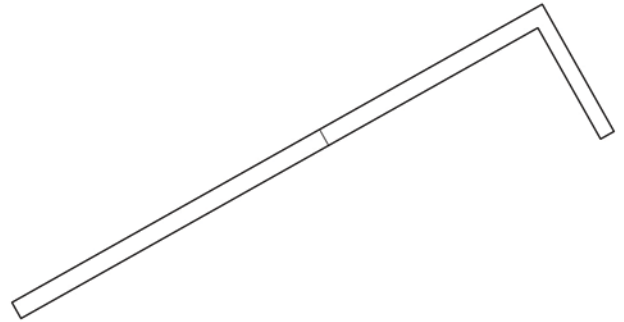
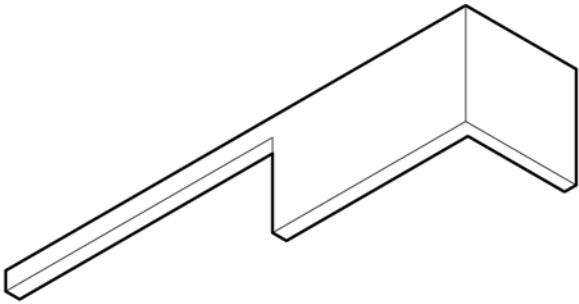

Sheet

Moulding

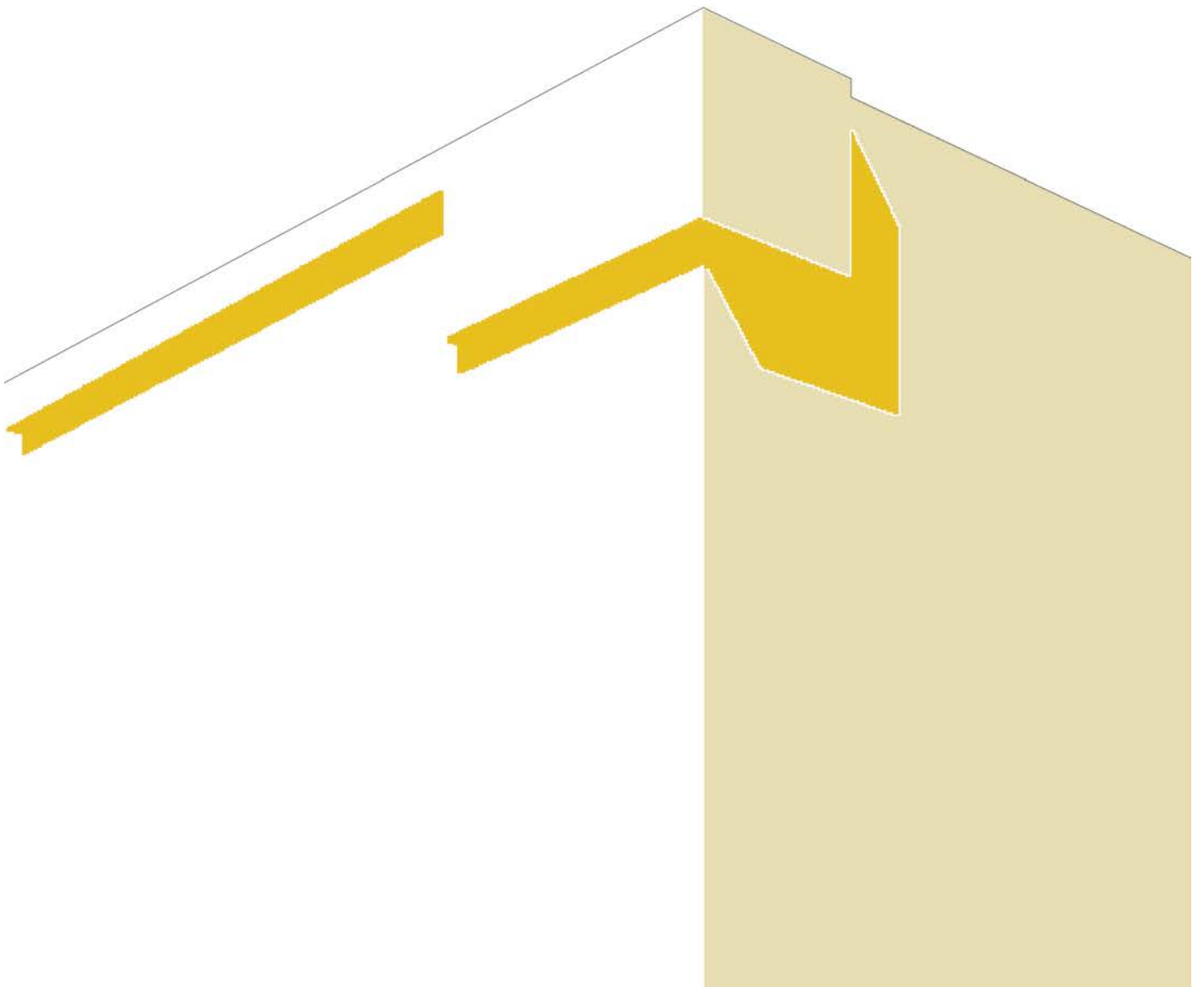

Sheet

Moulding

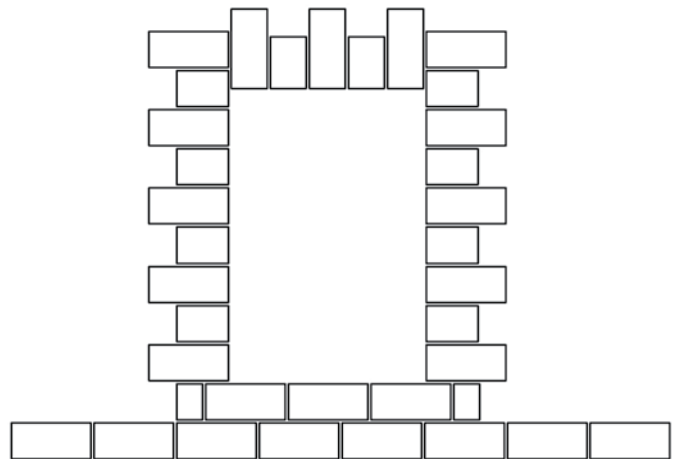
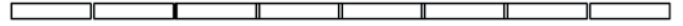
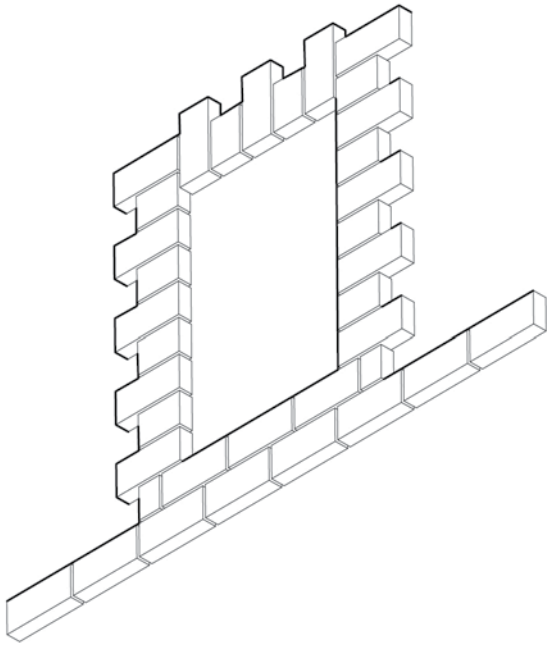

Faux Brick

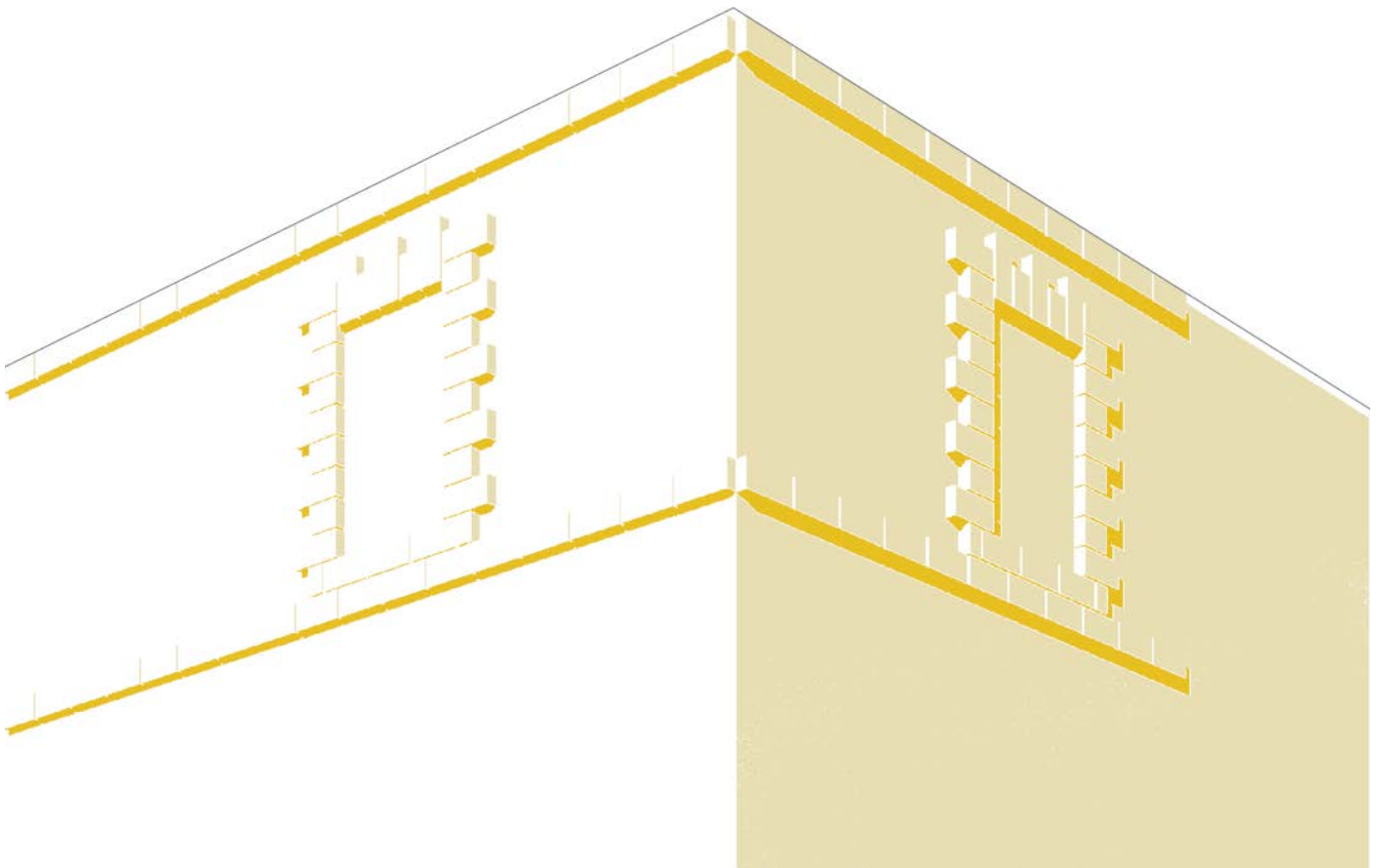

Faux Brick

Moulding

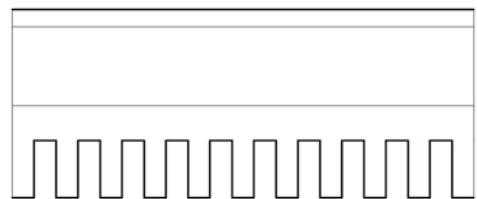
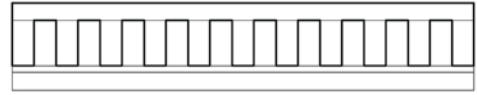
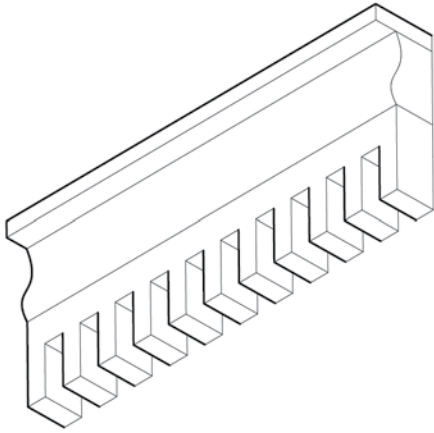

Composite

Moulding

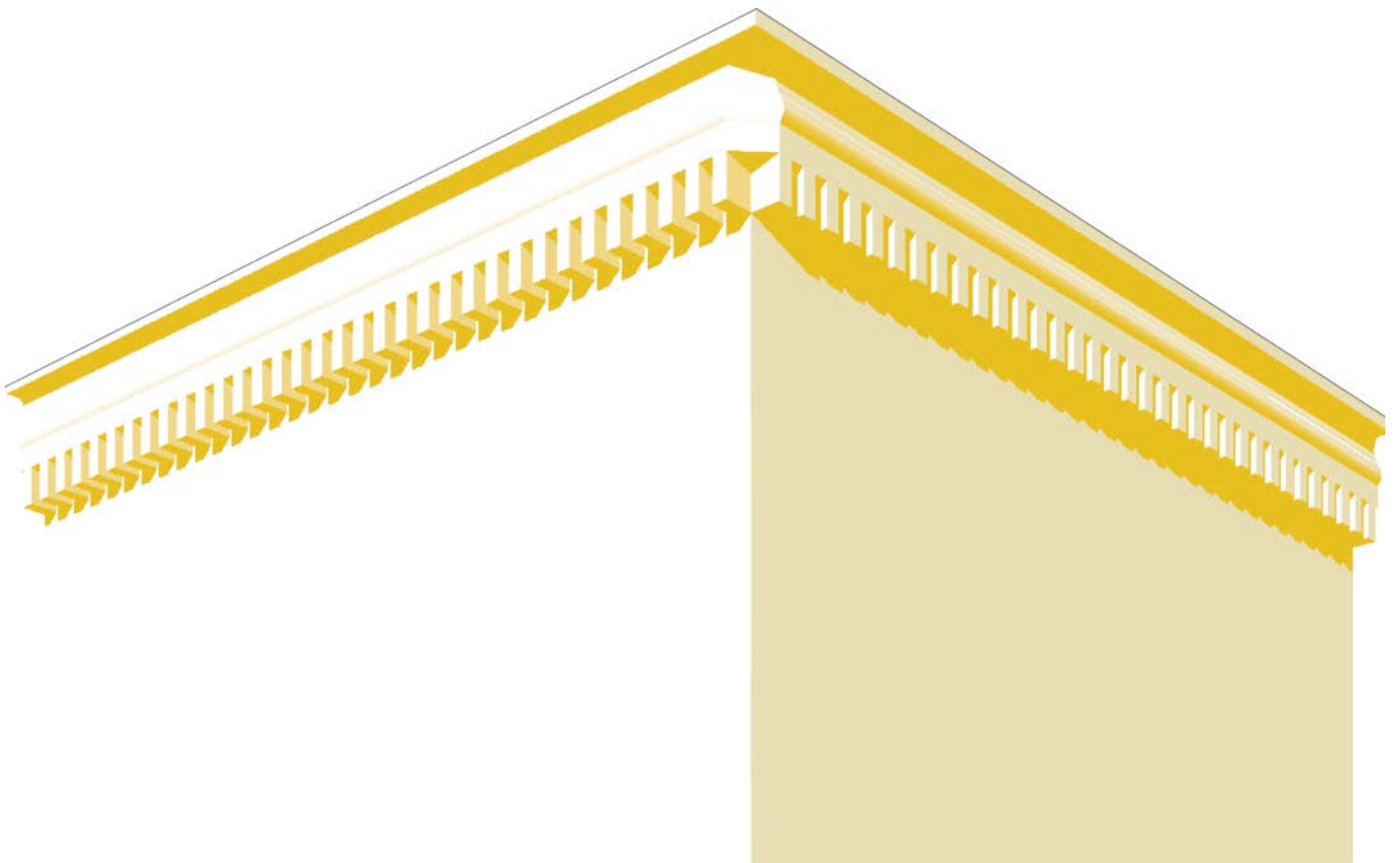

Composite

Accessories

Raj Periwal, Boya Chao



Built-in Planters

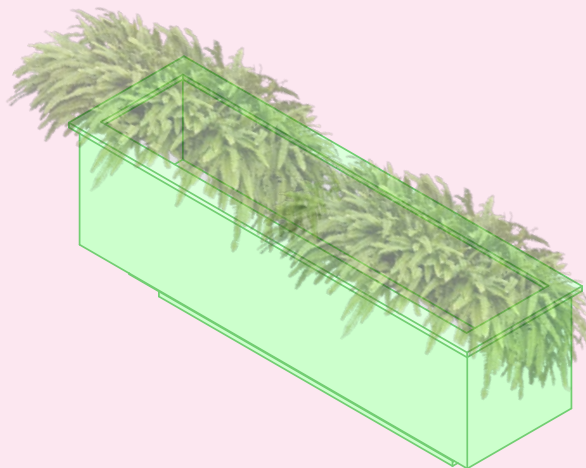
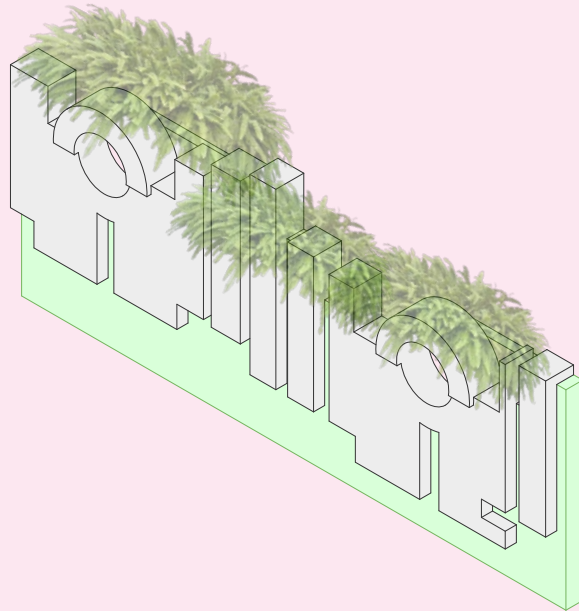
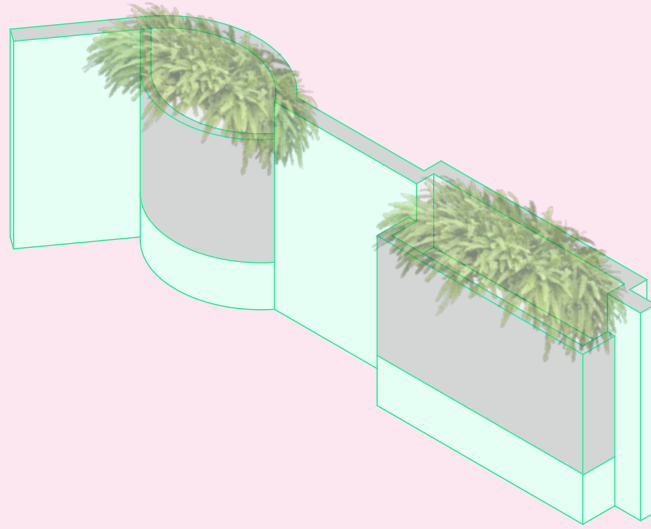

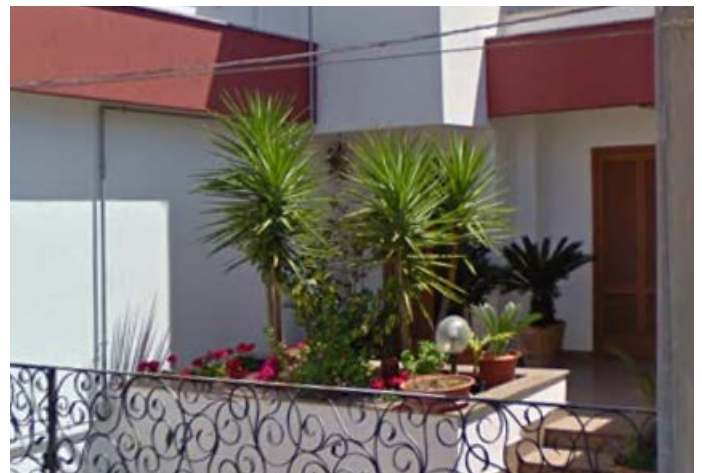

Built-in Planters

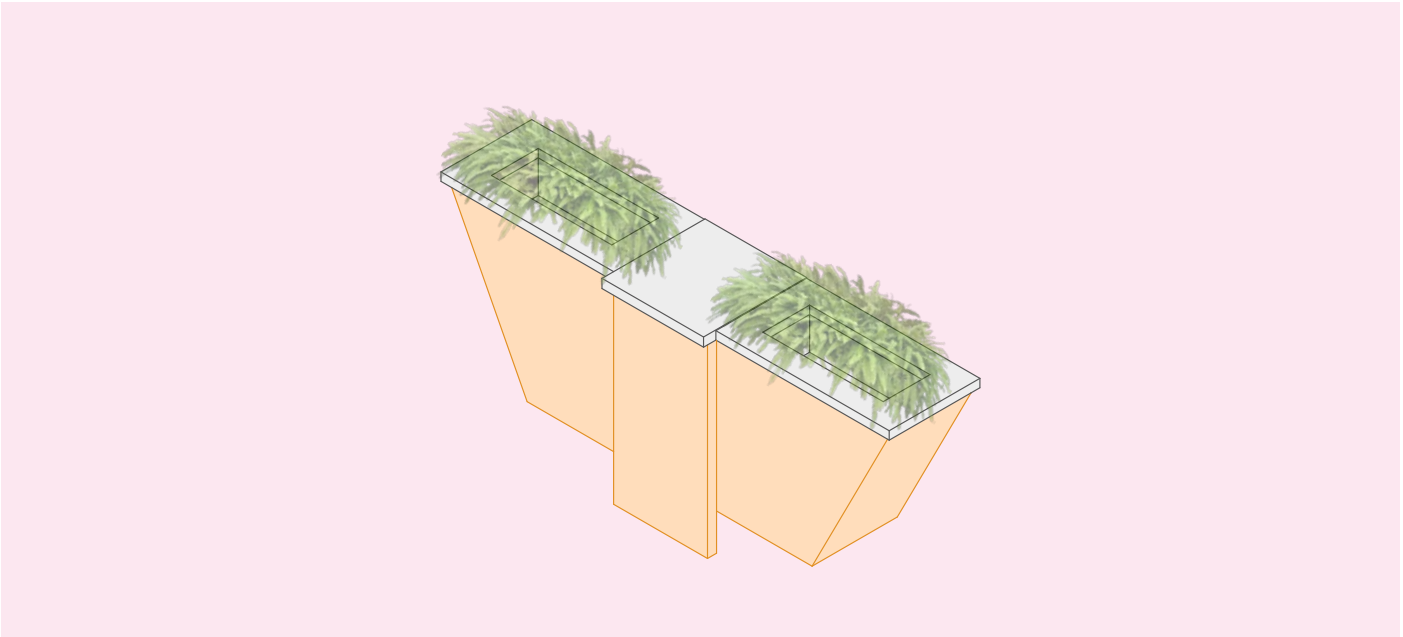
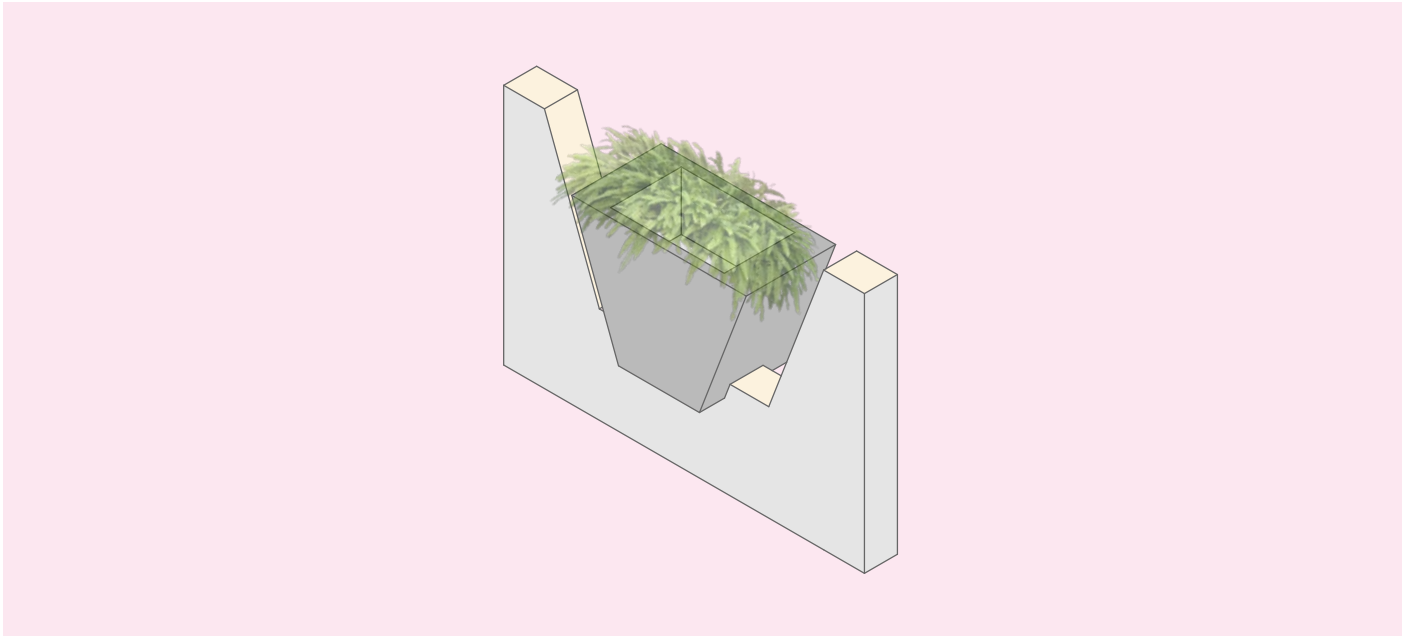
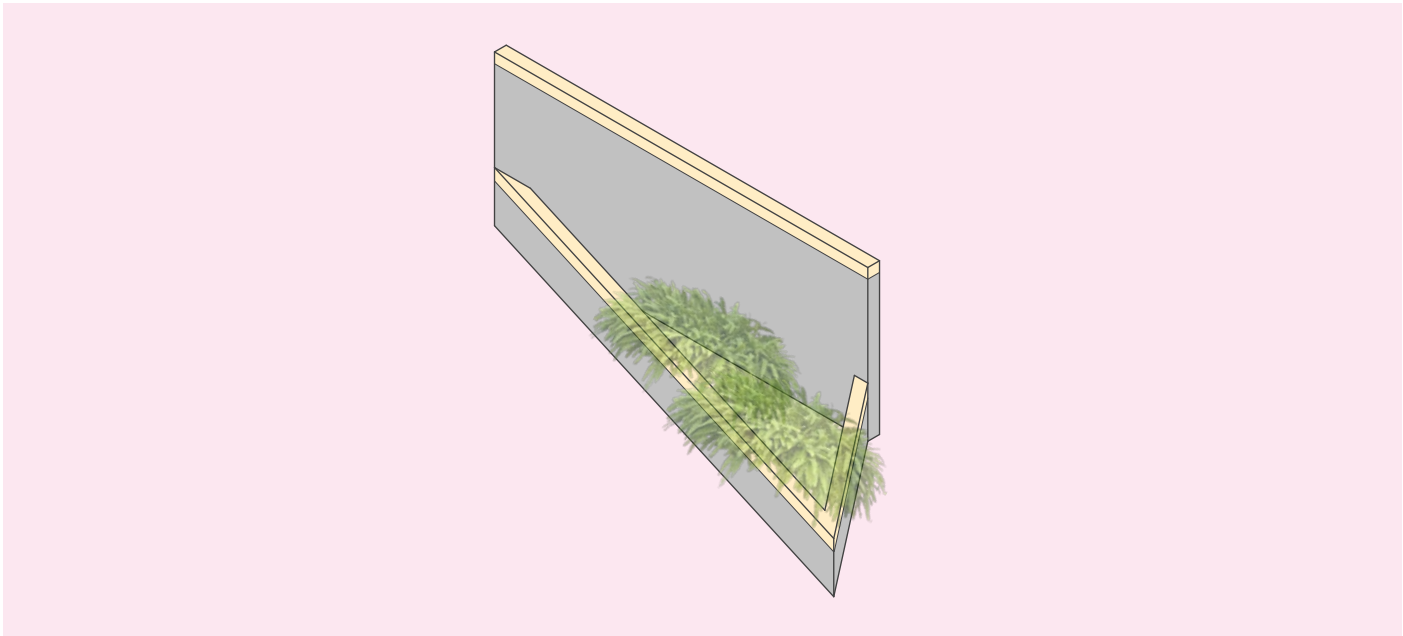

Built-in Planters

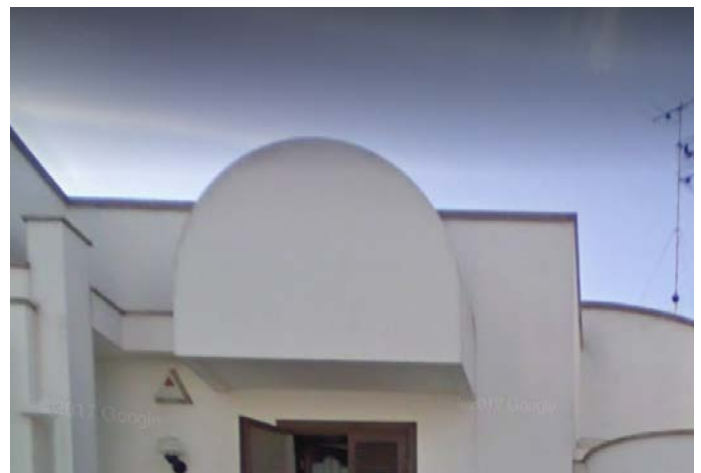

Overhangs

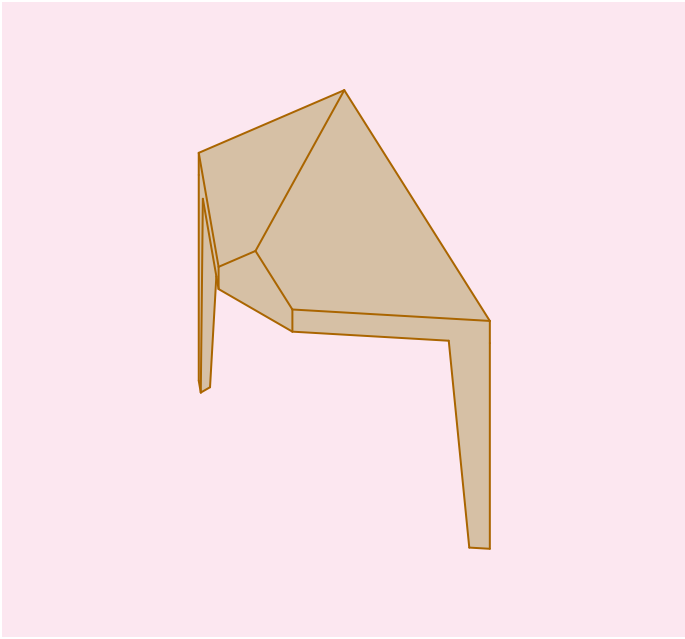
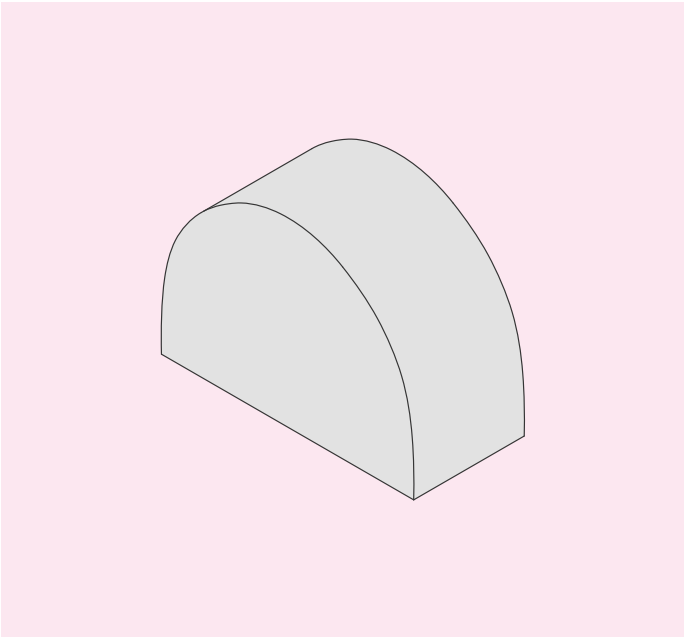
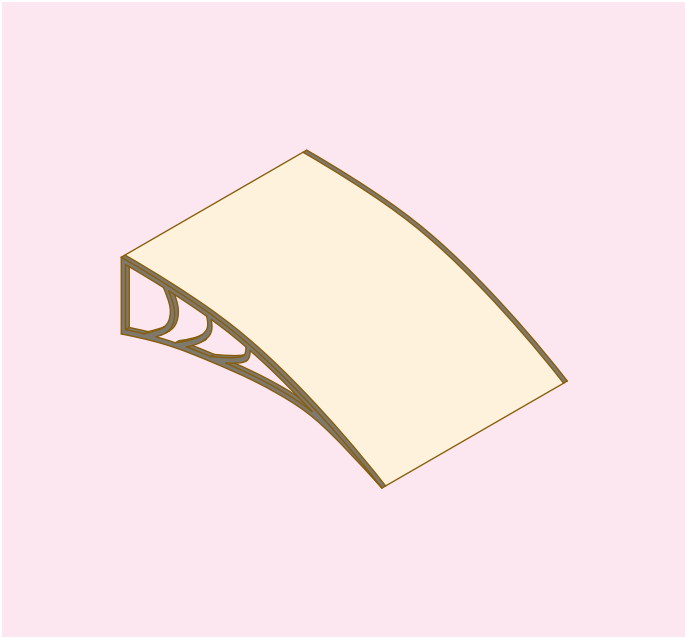
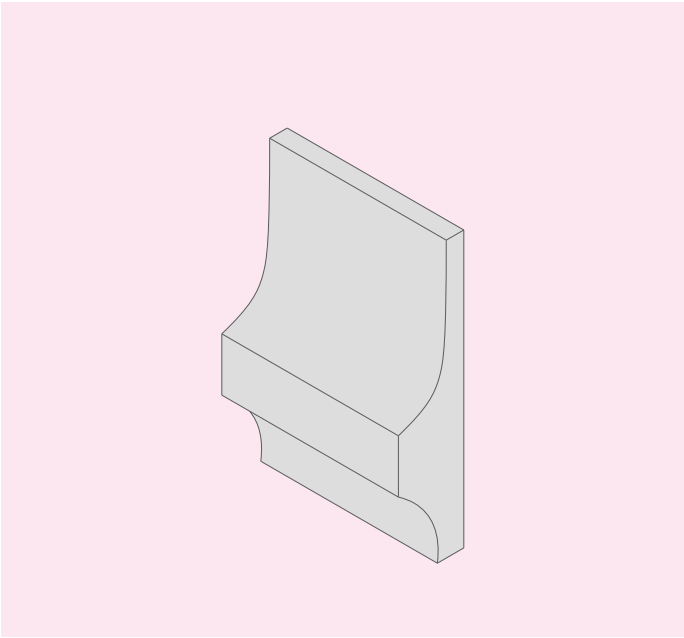
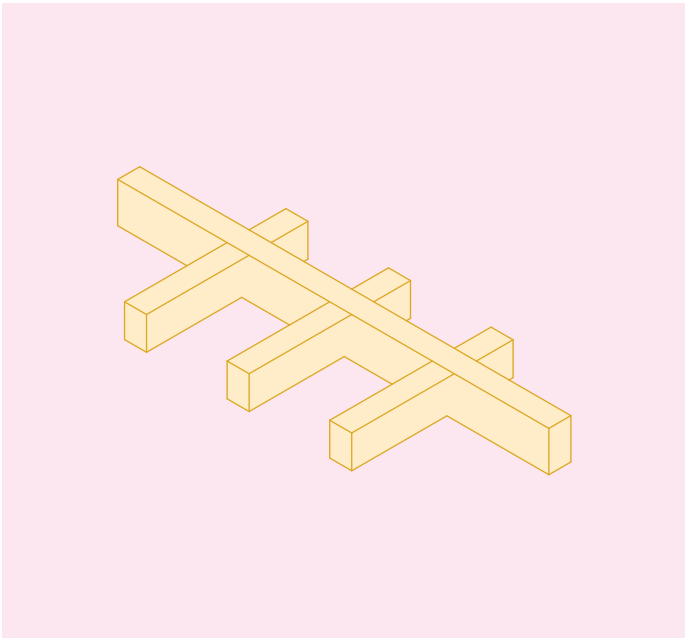
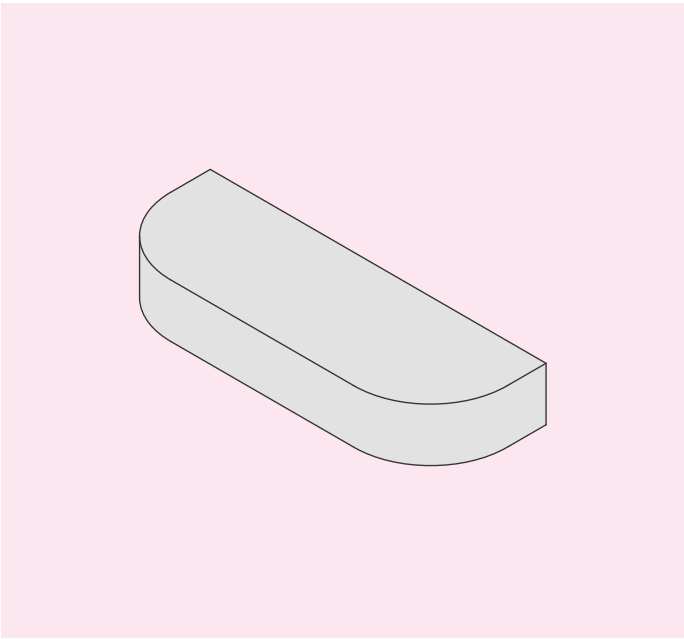

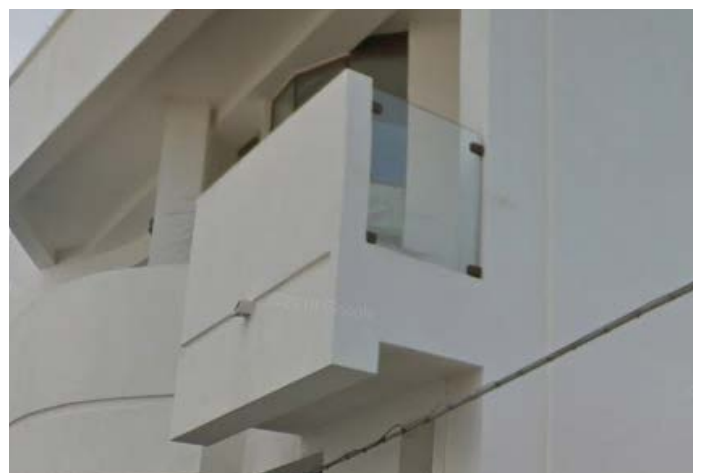

Balconies

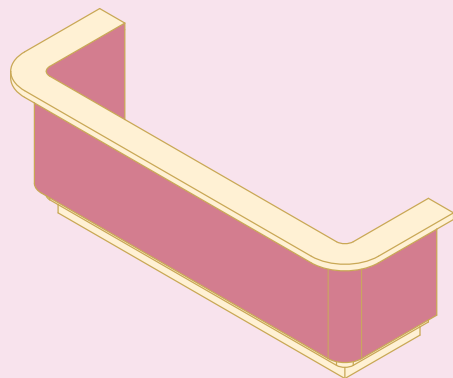
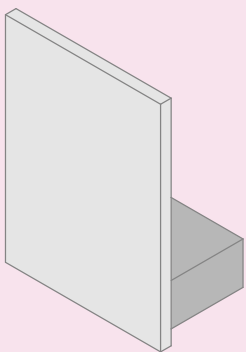
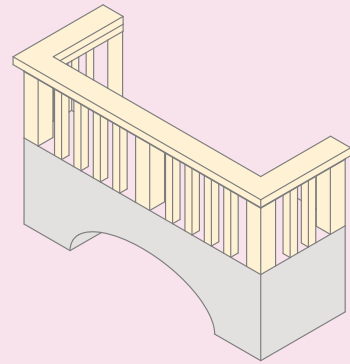
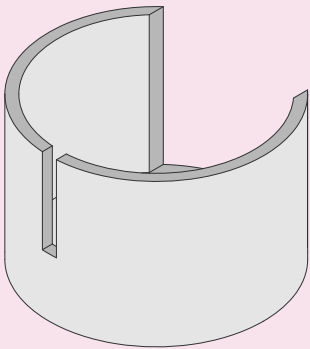
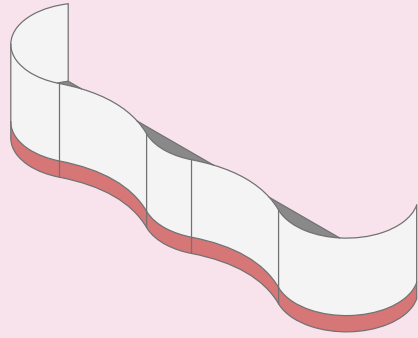
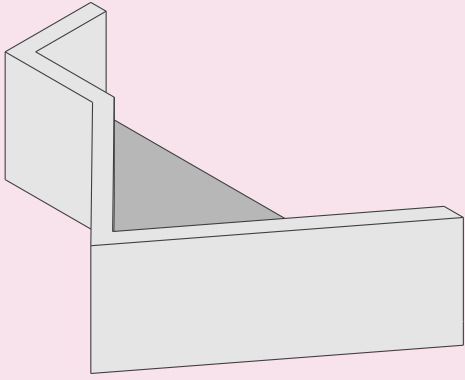

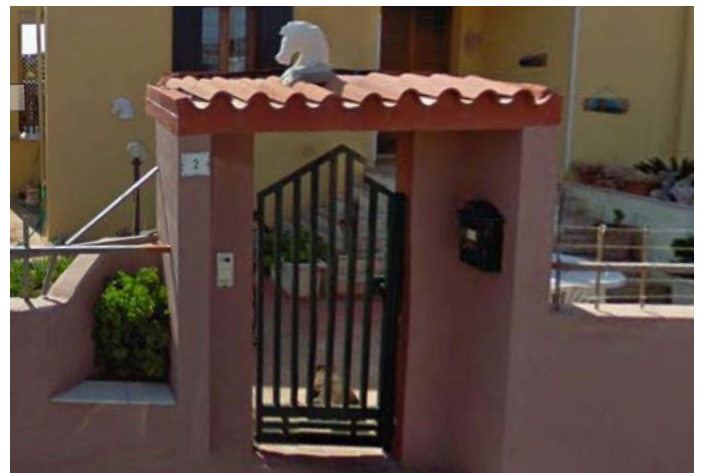

Entryways

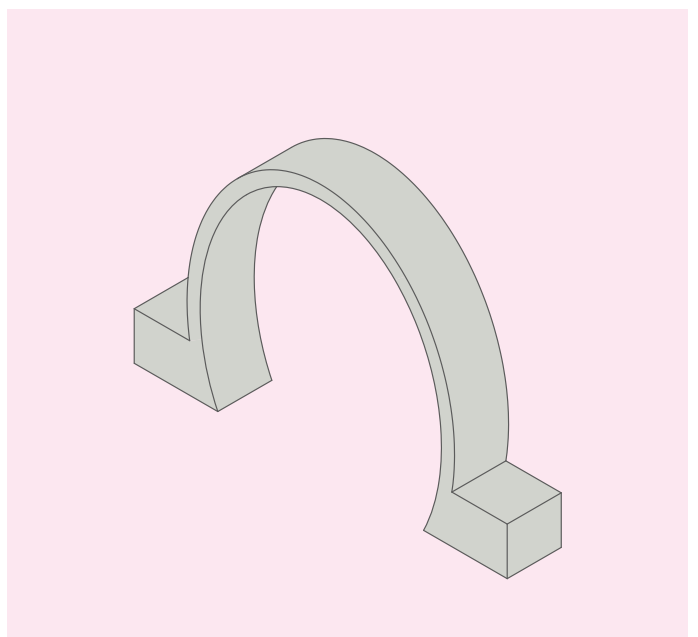
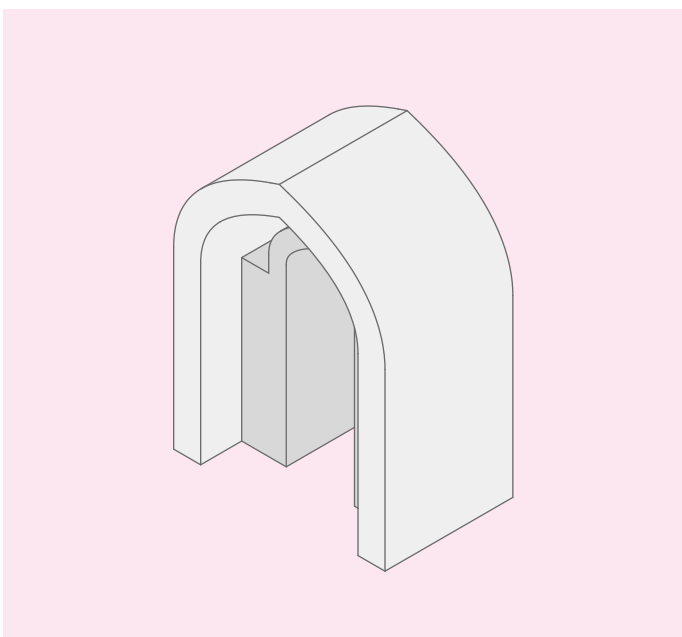
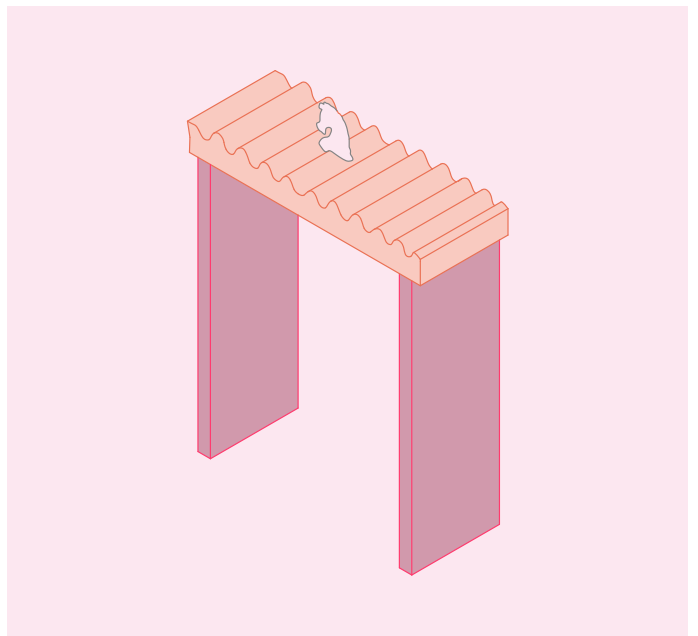
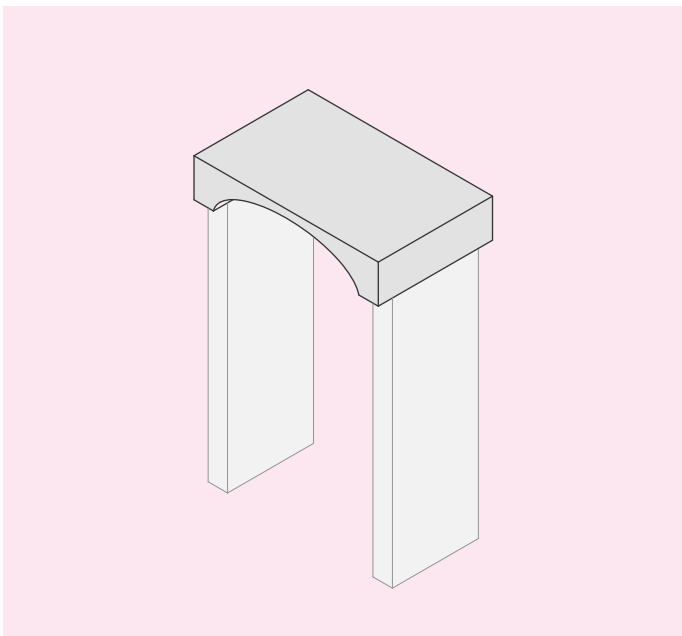
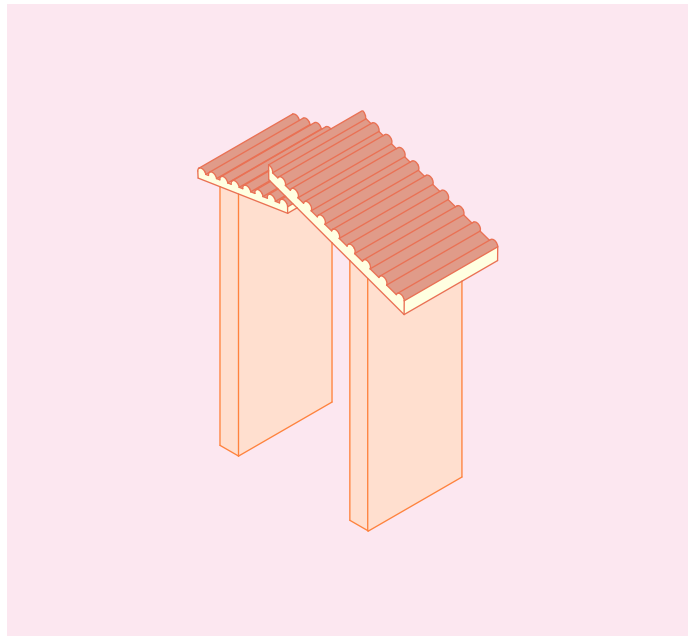
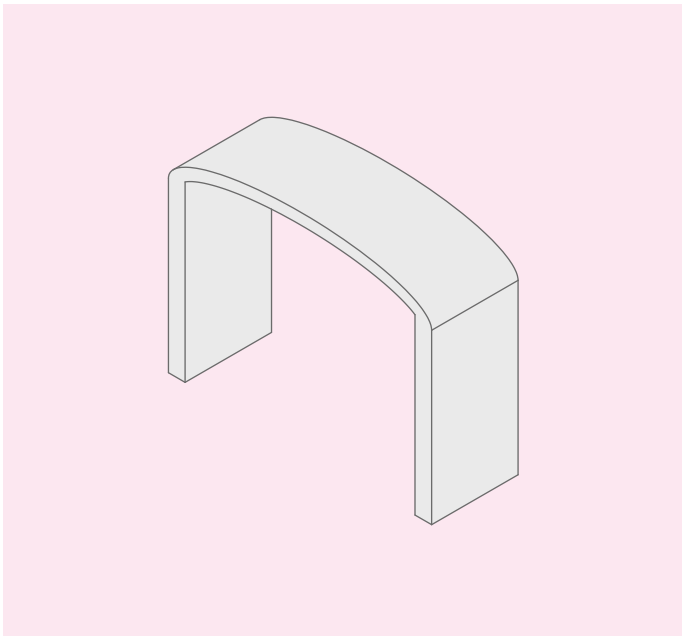

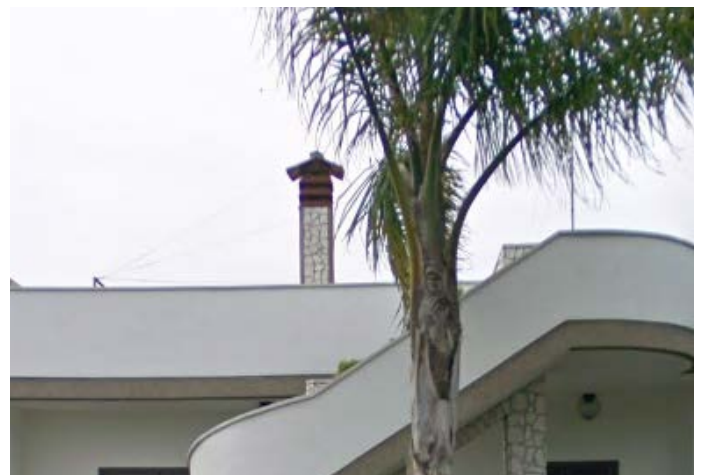
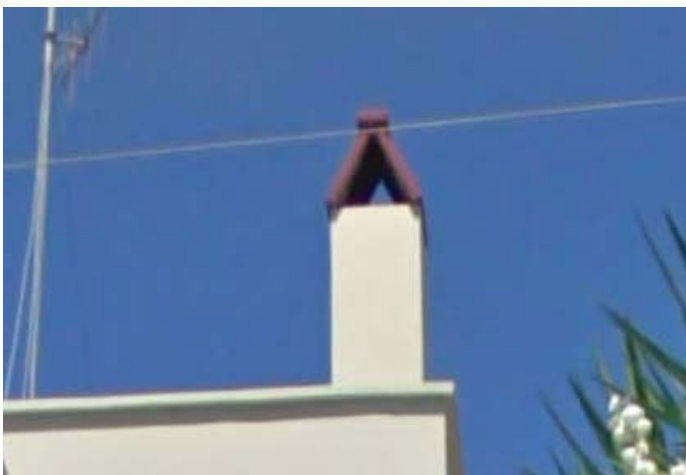

Chimneys

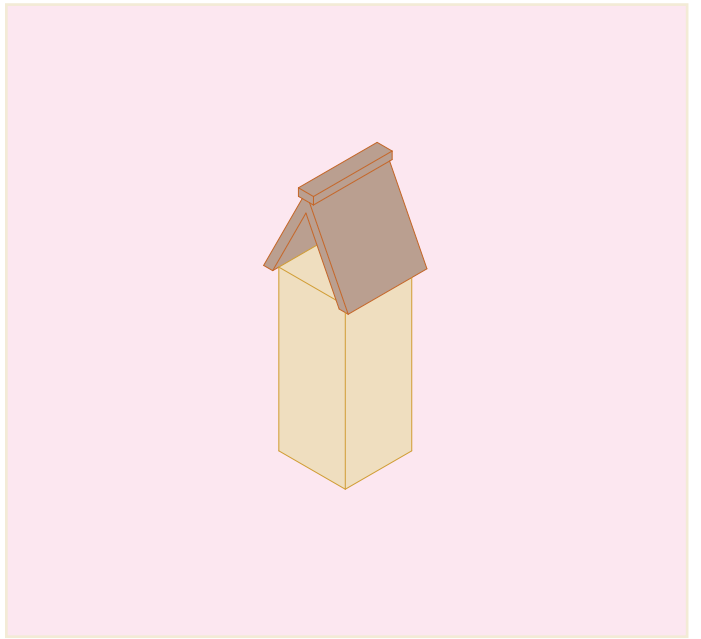
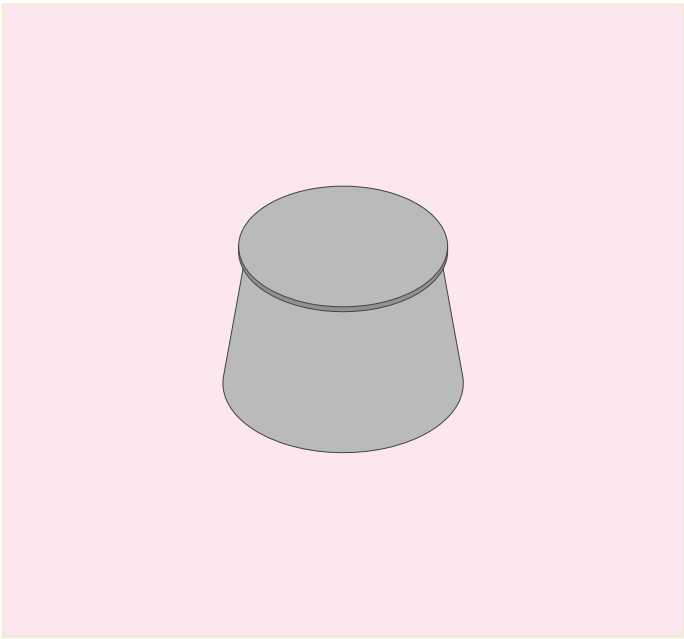
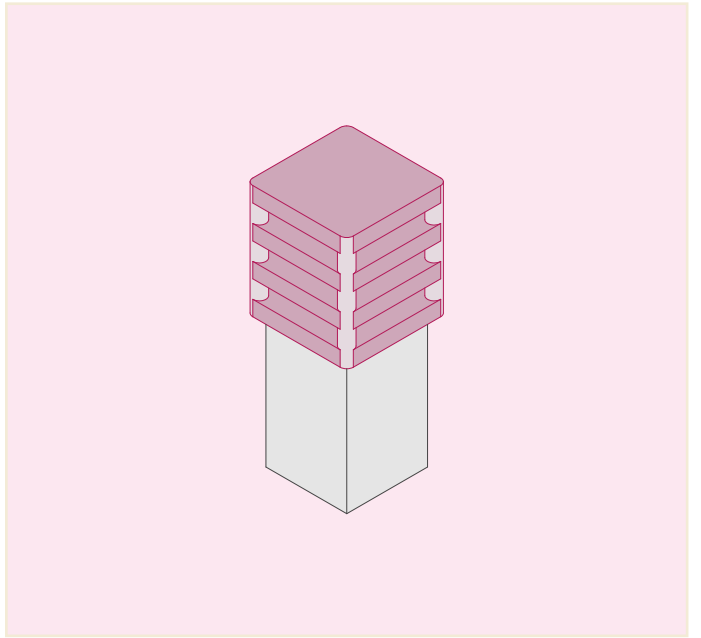
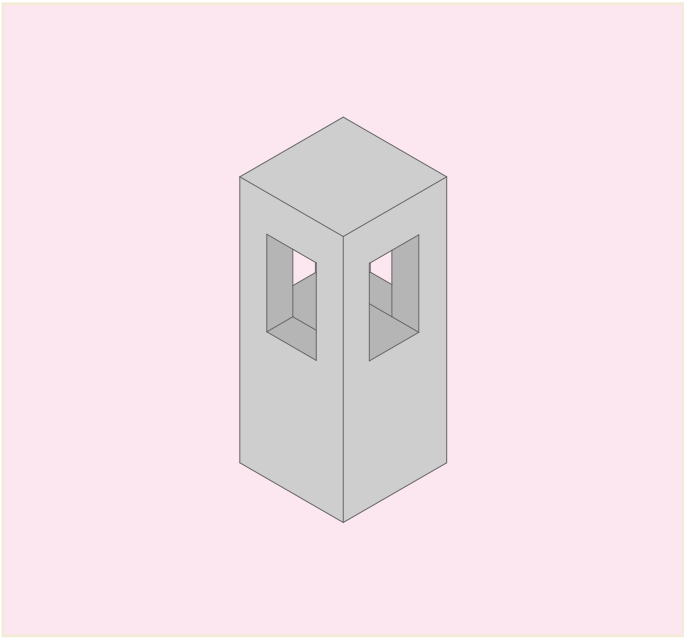
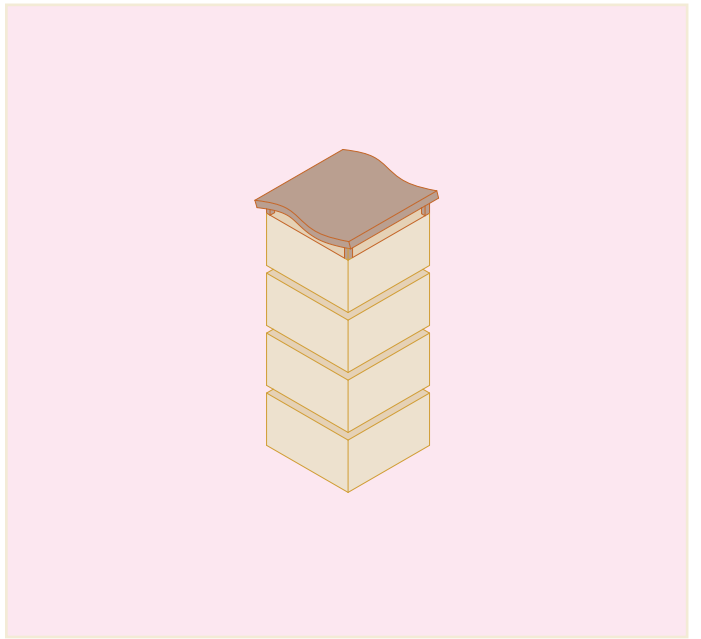
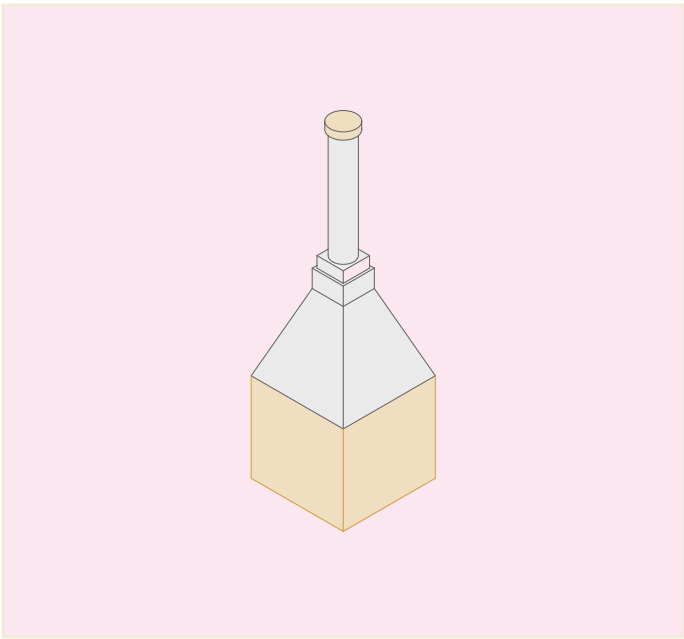

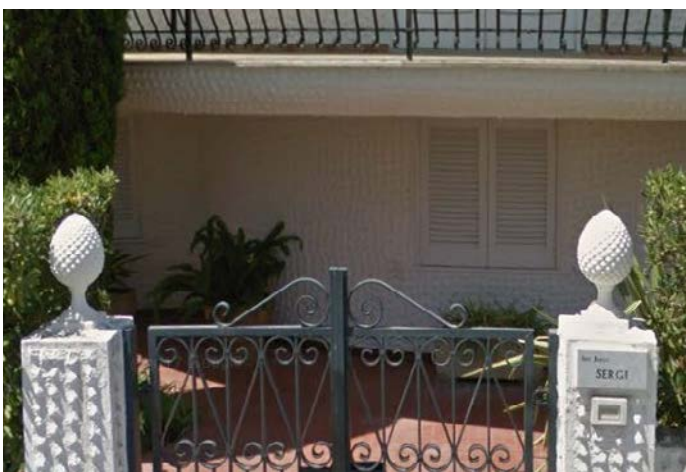

Miscellaneous Objects

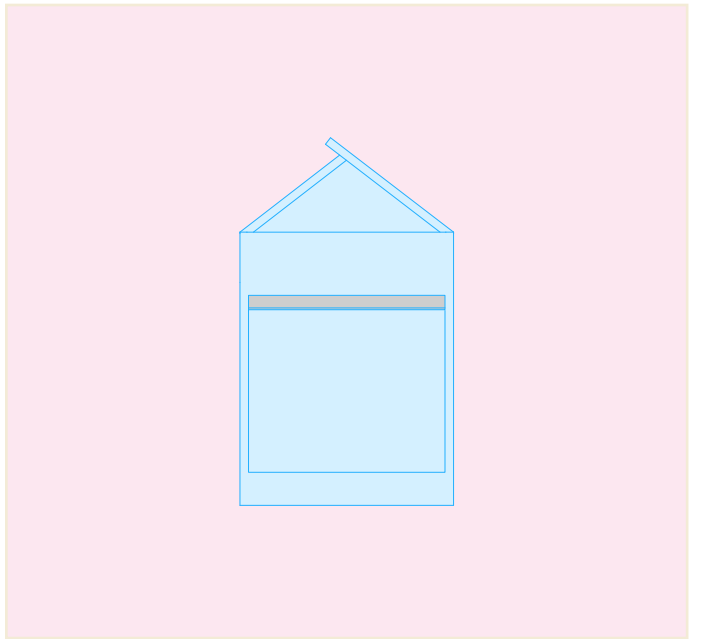
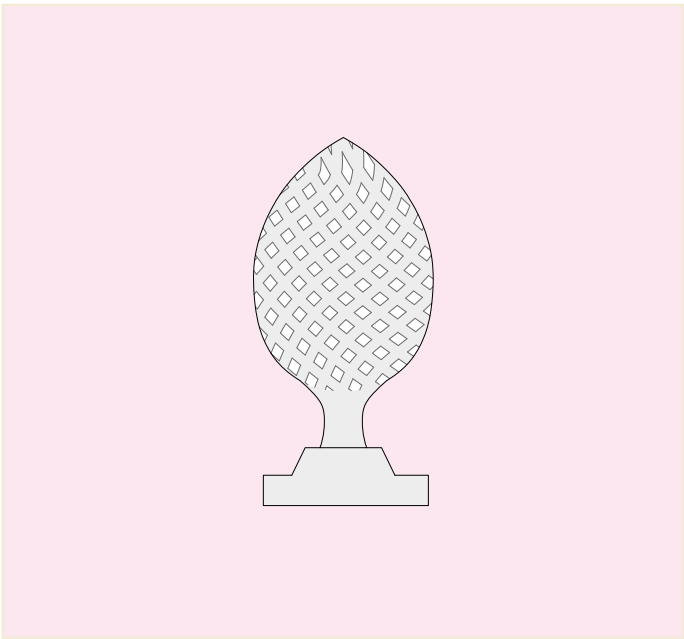
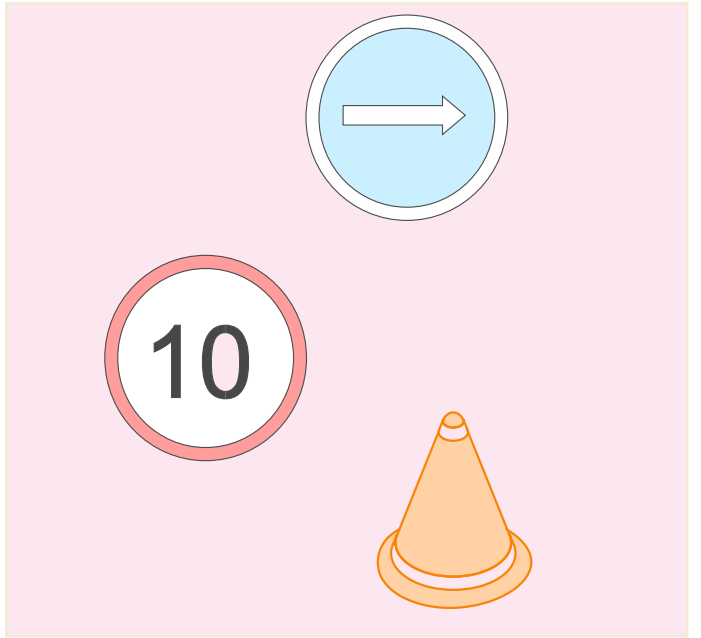
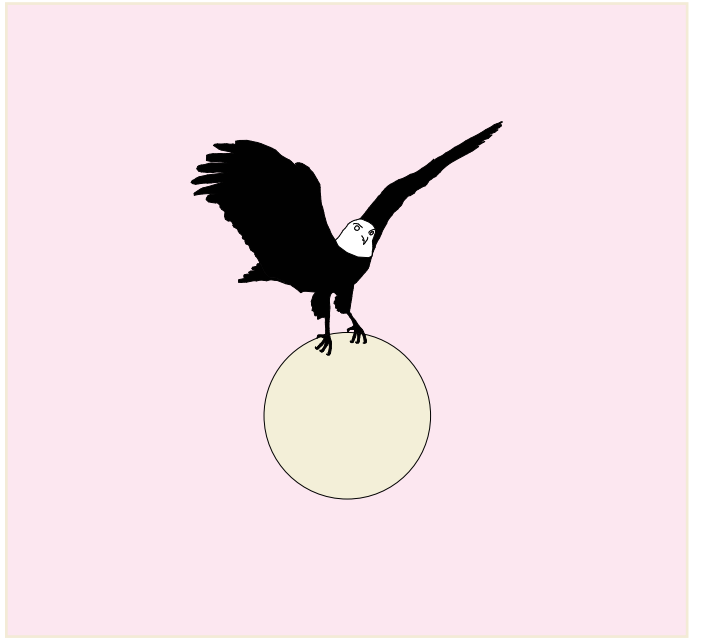
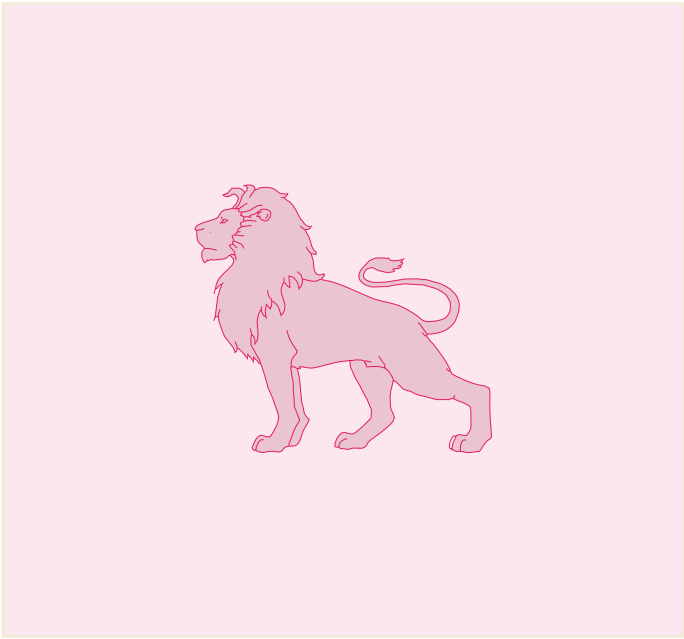

Miscellaneous Objects

**SYRACUSE
ARCHITECTURE**

